



# High-Performance Packaged Boiler

Australia's largest certified  
package boiler company.



**The Environmental  
Group Limited**  
*Engineering a Sustainable Future*

The Environmental Group Limited

[www.environmental.com.au](http://www.environmental.com.au)

# Working across the Circular Economy

## Our Purpose

Engineering a sustainable future.

## Our Mission

To enable our clients to contribute to a cleaner environment by safely delivering pivotal solutions while generating value for our shareholders, staff, and partner industries.

## Our Team

Our local experts are dedicated to reducing waste and boosting energy performance. Trusted worldwide to provide the highest standards of service and support.

# Tomlinson Energy Services

*Part of The Environmental Group*

Tomlinson Energy Services is Australia's leading provider of packaged boiler solutions, delivering the highest combustion efficiency to keep operating costs low and performance high.

We specialise in custom design, installation, commissioning, and national servicing and repairs, complemented by our 24/7 emergency support.

With offices and a dedicated service team across Australia, Tomlinson Energy Services ensures boilers operate at peak performance for maximum efficiency and reliability.



# Offering Industry Leading Boilers

**Fulton** radically challenges the industry status quo resulting in game-changing new boiler designs including the VSRT Boiler and the ENDURA+ boiler, culminating in more than 25 new patents worldwide.

Fulton has maintained a reputation for quality and excellence since 1949. From Steam and Hydronic boilers to Thermal Fluid Heaters and Custom Engineered Systems, Fulton has a product for virtually any industrial or commercial heating application.



# ENDURA ULTRA-HIGH EFFICIENCY CONDENSING BOILER

## ENDURA® Ultra-High Efficiency Condensing Boilers

750,000 – 2 Million BTU/HR

- ▶ Duplex Stainless Heat Exchanger
- ▶ Flame-by-Wire™ Combustion
- ▶ Real-Time O<sub>2</sub> Compensation™



## GREATER THAN THE SUM OF ITS PARTS

ENDURA® condensing boilers provide quiet and reliable operation in a compact firetube platform with efficiencies up to 99%. The highly engineered construction is built to last with thicker, higher-strength materials, and a premium fit and finish reflecting Fulton's paramount quality.

- ▶ Flame-by-Wire™ Combustion Control
- ▶ Up to 15:1 Turndown Burner
- ▶ Feed Forward O<sub>2</sub> Compensation™
- ▶ Low NO<sub>x</sub> Emissions of <20 ppm
- ▶ Lower Cost of Ownership

## COMPLEXITY SIMPLIFIED

PURE Control™ provides rapid access to operating details and configuration. It efficiently sequences up to 10 boilers and eliminates the need for a master boiler or standalone panel. When a boiler is powered off, the plant seamlessly transitions to the next available stage for reliable heat you can count on.

- ▶ Outdoor Reset with Setback Mode
- ▶ Motorized Isolation Valve Control
- ▶ Variable Speed Pump Control
- ▶ Saves Energy by Reducing Cycling
- ▶ Modbus / BACnet Configurable

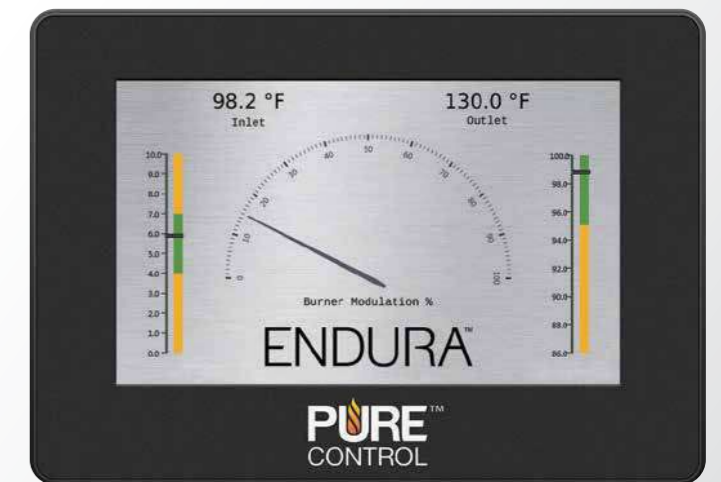
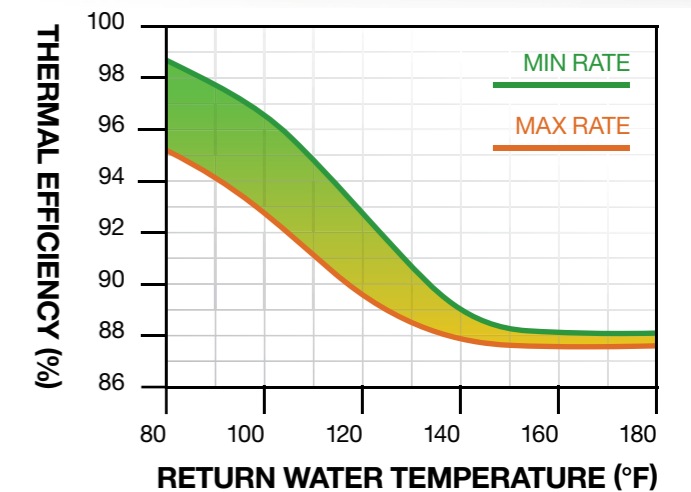

## DESIGNED FOR VARIABLE PRIMARY FLOW

Variable primary flow is a simplified piping method which enhances temperature control, reduces design complexity, and maximizes efficiencies by delivering the lowest temperature water directly to the boiler with no blending.

- ▶ No Dedicated Circulator Pump
- ▶ Reduced Installation Cost
- ▶ Smaller Plant Footprints

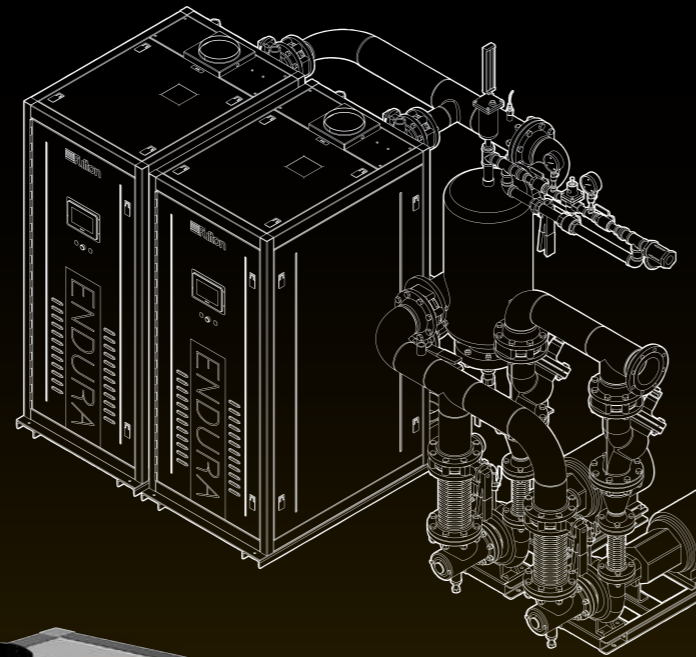

## BETTER BY DESIGN

Proven as the premier choice for long-lasting rugged construction, Fulton's 3-pass design architecture has been the industry's trusted condensing boiler for more than 30 years.



**LIFETIME**  
THERMAL SHOCK WARRANTY  
★★★

- ▶ Duplex stainless steel heat exchanger features 160% greater yield strength and a 22% reduction in thermal expansion compared to conventional 316L used by the competition.
- ▶ High-mass and high volume firetube design operates with lower stresses and therefore greater durability.
- ▶ Exceptionally tolerant of varying and sometimes unpredictable system flow rates; will not be harmed by a zero flow condition.

## SPECIFICATIONS & DIMENSIONS

	MODEL	EDR-750	EDR-1000	EDR-1500	EDR-2000
<b>SPECIFICATIONS</b>					
Input Capacity	MBH	750	1,000	1,500	2,000
Water Content	GAL	50	50	104	102
Pressure Drop at 20°F ΔT	PSI	0.5	0.7	0.8	1.5
Operating Weight	LBS	1,848	1,848	3,128	3,210
AHRI Thermal Efficiency	%	97.1	95.3	93.5	93.7
Turndown Ratio		8:1	11:1	11:1	15:1
<b>DIMENSIONS</b>					
(A) Height	IN	67.9	67.9	80.25	80.25
(B) Width	IN	28	28	34	34
(C) Depth	IN	42	42	50.8	50.8
<b>CLEARANCES</b>					
(E) Sides	IN	1	1	1	1
(F) Front	IN	36	36	36	36
(G) Top	IN	18	18	18	18
(H) Rear	IN	24	24	24	24

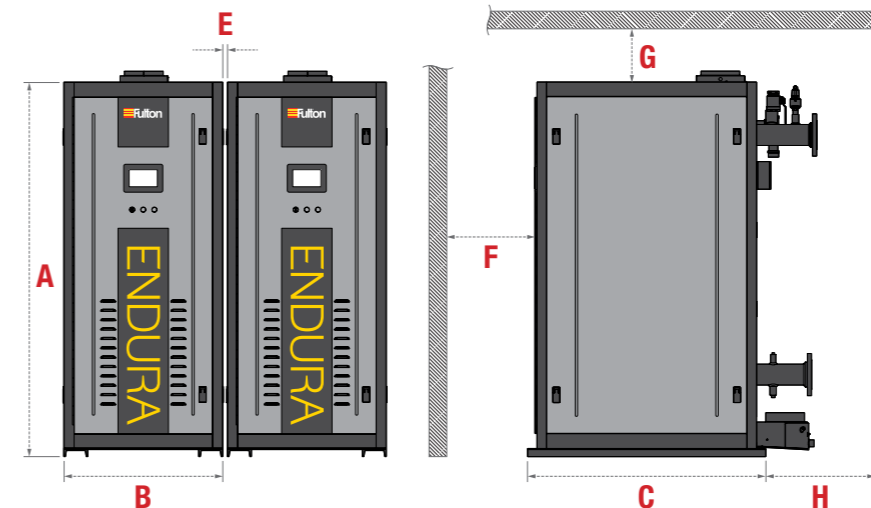

**LIFETIME** \* **10 YEAR** \* **5 YEAR** \*  
THERMAL SHOCK WARRANTY ★★★  
HEAT EXCHANGER WARRANTY ★★★  
BURNER WARRANTY ★★★

NOTE: Specifications and dimensions are approximate and for reference only. Fulton practices continuous product improvement and reserves the right to change data without notice.

## Reliability & Lower Emissions

Flame-by-Wire™ combustion technology replaces the use of conventional “neg-reg” and mechanical linkages with a modern system of independent electronic air and gas valves. It is easier to service and tune by empowering technicians to dial in air-fuel ratios with surgical precision.

## Space-Saving Design

A compact footprint allows ENDURA boilers to fit through a standard door and requires only one-inch of side clearance between boilers, freeing up valuable mechanical room space.

## Easy to Install and Maintain

ENDURA's latched cabinet panels detach in seconds, providing easy access for commissioning and maintenance. Complete boiler service can be performed through the front, top, and rear.



# Contact Us



Maximising Energy Efficiencies for a Sustainable Future

[admin@egl.com.au](mailto:admin@egl.com.au)

[www.environmental.com.au](http://www.environmental.com.au)

03 9541 8699

## Office Locations



### Melbourne

Tomlinson Energy Services  
Suite 2.01 | Level 2  
315 Ferntree Gully Road  
Mount Waverley VIC 3149

P: 03 8560 0416

E: [energyservice.melbourne@tomlinsonenergy.com.au](mailto:energyservice.melbourne@tomlinsonenergy.com.au)

### Sydney

Tomlinson Energy Services  
A2, 26 Power Road  
Seven Hills NSW 2417

P: 02 9681 4177

E: [energyservice.sydney@tomlinsonenergy.com.au](mailto:energyservice.sydney@tomlinsonenergy.com.au)

### Brisbane

Tomlinson Energy Services  
1/48 Commerce Circuit  
Yatala QLD 4207

P: 07 3462 0159

E: [energyservice.brisbane@tomlinsonenergy.com.au](mailto:energyservice.brisbane@tomlinsonenergy.com.au)

### South Australia

Tomlinson Energy Services  
26 Phillips Street  
Thebarton SA 5031

P: 08 8297 9688

E: [energyservice.adelaide@tomlinsonenergy.com.au](mailto:energyservice.adelaide@tomlinsonenergy.com.au)

### Western Australia

Tomlinson Energy Services  
40 Sorbonne Crescent  
Canning Vale WA 6155

P: 08 9455 5511

E: [energyservice.perth@tomlinsonenergy.com.au](mailto:energyservice.perth@tomlinsonenergy.com.au)



**The Environmental  
Group Limited**  
*Engineering a Sustainable Future*