



# High-Performance Packaged Boiler

Australia's largest certified  
package boiler company.



**The Environmental  
Group Limited**  
*Engineering a Sustainable Future*

The Environmental Group Limited

[www.environmental.com.au](http://www.environmental.com.au)

# Working across the Circular Economy

## Our Purpose

Engineering a sustainable future.

## Our Mission

To enable our clients to contribute to a cleaner environment by safely delivering pivotal solutions while generating value for our shareholders, staff, and partner industries.

## Our Team

Our local experts are dedicated to reducing waste and boosting energy performance. Trusted worldwide to provide the highest standards of service and support.

# Tomlinson Energy Services

*Part of The Environmental Group*

Tomlinson Energy Services is Australia's leading provider of packaged boiler solutions, delivering the highest combustion efficiency to keep operating costs low and performance high.

We specialise in custom design, installation, commissioning, and national servicing and repairs, complemented by our 24/7 emergency support.

With offices and a dedicated service team across Australia, Tomlinson Energy Services ensures boilers operate at peak performance for maximum efficiency and reliability.



# Offering Industry Leading Boilers

**Fulton** radically challenges the industry status quo resulting in game-changing new boiler designs including the VSRT Boiler and the ENDURA+ boiler, culminating in more than 25 new patents worldwide.

Fulton has maintained a reputation for quality and excellence since 1949. From Steam and Hydronic boilers to Thermal Fluid Heaters and Custom Engineered Systems, Fulton has a product for virtually any industrial or commercial heating application.



# FBL HIGH EFFICIENCY ELECTRICAL STEAM BOILER

## FBL High Efficiency Electric Steam Boiler

12 – 1,000 kW

- ▶ Nearly 100% Efficient
- ▶ Zero Emissions
- ▶ Compact & Quiet

Fulton's complete line of electric steam boilers are fully packaged and environmentally friendly with zero NOx emissions. Boilers feature a rugged design with fully-insulated pressure vessels for minimal radiation losses. A carefully calculated heat-to-steam ratio achieves operating pressures quickly and with nearly 100% efficiency.

## SPECIFICATIONS & DIMENSIONS

MODEL FB:	012L	015L	018L	024L	030L	036L	050L	075L	100L	150L	200L	300L	500L	750L	1000L	
<b>SPECIFICATIONS</b>																
Unit Size	kW	12	15	18	24	30	36	50	75	100	150	200	300	500	750	1,000
	HP	1.2	1.5	1.8	2.4	3	3.6	5	7.5	10	15	20	30	50	75	100
Steam Output*	LBS/HR	42	53	63	84	105	126	175	263	350	525	700	1050	1750	2625	3500
Element Count		1	1	1	2	2	2	2	3	4	6	4	4	7	10	14
<b>ELECTRICAL</b>																
240V / 3 Phase	Amps	32	40	47	61	76	90	124	184	244	364	485	725	1206	1808	2409
480V / 3 Phase	Amps	16	20	24	31	38	45	62	92	122	182	243	363	603	904	1205
575V / 3 Phase	Amps	14	17	20	26	32	38	52	77	102	152	203	303	504	755	1006
<b>DIMENSIONS</b>																
(A) Boiler Height	IN	36	36	36	36	36	36	56	56	56	58	59	75	76	94	94
(B) Height w/ Piping	IN	36	36	36	36	36	36	56	56	56	58	59	75	76	94	94
(C) Width Overall	IN	40	40	40	40	40	40	38	42	42	44	64	64	77	88	104
(D) Depth Overall	IN	35	35	35	35	35	35	34	41	41	47	58	60	71	92	92
(E) Boiler Diameter	IN	20	20	20	20	20	20	18	25	25	29	33	37	45	50	64

\* Steam output ratings at 212°F feedwater (0 PSIG)

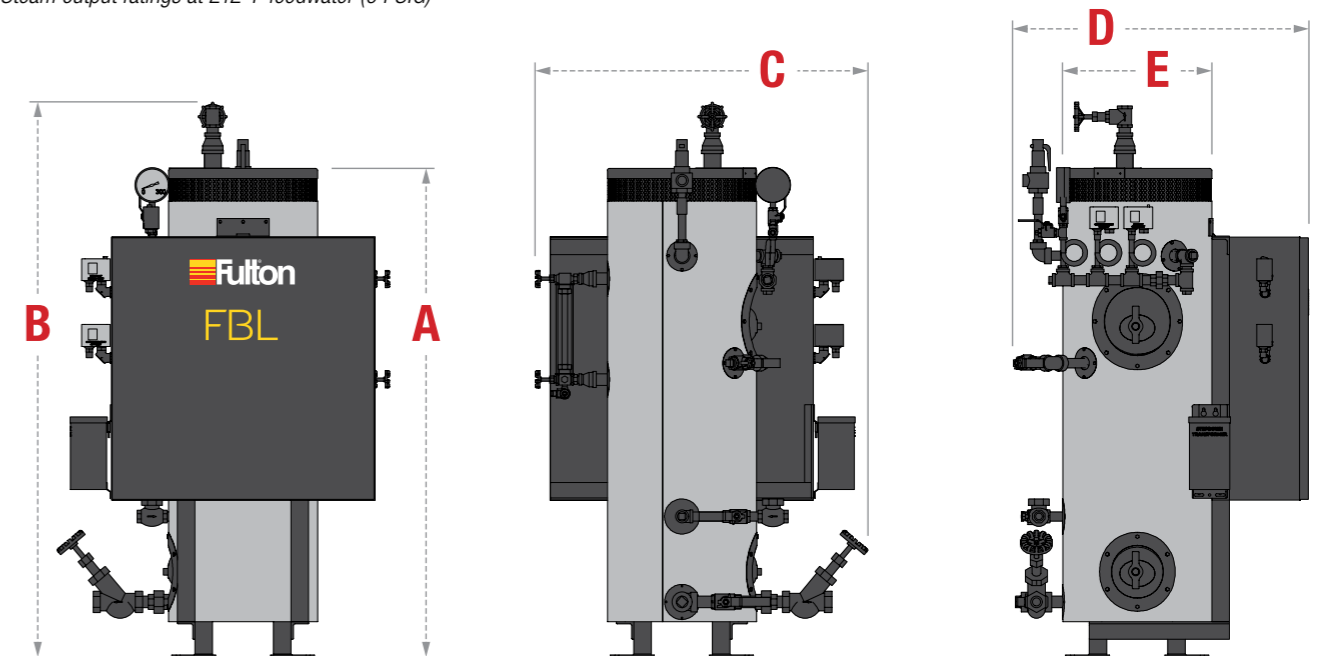

NOTE: Specifications and dimensions are approximate and for reference only. Fulton practices continuous product improvement and reserves the right to change specifications and/or dimensions without notice.



Process  
Manufacturing



Commercial &  
Industrial Facilities



Education



Food & Beverage  
Processing



Military Bases &  
Government  
Facilities



Healthcare



Pharmaceutical  
Processing and  
Biotech



Agriculture



Utilities

# Contact Us



Maximising Energy Efficiencies for a Sustainable Future

[admin@egl.com.au](mailto:admin@egl.com.au)

[www.environmental.com.au](http://www.environmental.com.au)

03 9541 8699

## Office Locations



### Melbourne

Tomlinson Energy Services  
Suite 2.01 | Level 2  
315 Ferntree Gully Road  
Mount Waverley VIC 3149

P: 03 8560 0416

E: [energyservice.melbourne@tomlinsonenergy.com.au](mailto:energyservice.melbourne@tomlinsonenergy.com.au)

### Sydney

Tomlinson Energy Services  
A2, 26 Power Road  
Seven Hills NSW 2417

P: 02 9681 4177

E: [energyservice.sydney@tomlinsonenergy.com.au](mailto:energyservice.sydney@tomlinsonenergy.com.au)

### Brisbane

Tomlinson Energy Services  
1/48 Commerce Circuit  
Yatala QLD 4207

P: 07 3462 0159

E: [energyservice.brisbane@tomlinsonenergy.com.au](mailto:energyservice.brisbane@tomlinsonenergy.com.au)

### South Australia

Tomlinson Energy Services  
26 Phillips Street  
Thebarton SA 5031

P: 08 8297 9688

E: [energyservice.adelaide@tomlinsonenergy.com.au](mailto:energyservice.adelaide@tomlinsonenergy.com.au)

### Western Australia

Tomlinson Energy Services  
40 Sorbonne Crescent  
Canning Vale WA 6155

P: 08 9455 5511

E: [energyservice.perth@tomlinsonenergy.com.au](mailto:energyservice.perth@tomlinsonenergy.com.au)



**The Environmental  
Group Limited**  
*Engineering a Sustainable Future*