



High-Performance Packaged Boiler

Australia's largest certified
package boiler company.



**The Environmental
Group Limited**
Engineering a Sustainable Future

The Environmental Group Limited

www.environmental.com.au

Working across the Circular Economy

Our Purpose

Engineering a sustainable future.

Our Mission

To enable our clients to contribute to a cleaner environment by safely delivering pivotal solutions while generating value for our shareholders, staff, and partner industries.

Our Team

Our local experts are dedicated to reducing waste and boosting energy performance. Trusted worldwide to provide the highest standards of service and support.

Tomlinson Energy Services

Part of The Environmental Group

Tomlinson Energy Services is Australia's leading provider of packaged boiler solutions, delivering the highest combustion efficiency to keep operating costs low and performance high.

We specialise in custom design, installation, commissioning, and national servicing and repairs, complemented by our 24/7 emergency support.

With offices and a dedicated service team across Australia, Tomlinson Energy Services ensures boilers operate at peak performance for maximum efficiency and reliability.



WM 20 MONARCH® BURNERS COMPACT AND POWERFUL (150–2600 KW)



– weishaupt –

Offering Industry Leading Burners

Weishaupt produces gas and oil-fired boilers, heat pumps, and burners. These top-quality products are characterised by their meticulous development, high-quality workmanship, outstanding operational reliability, and maximum Efficiency. Their unrivalled excellence extends equally to design and function.

Progress and tradition: The latest monarch[®] burner



The monarch[®] trademark has stood for power and quality for more than 60 years

For more than six decades, Weishaupt's monarch[®] series burners have been used on a wide variety of heat generators and industrial plant, and their success has helped underpin Weishaupt's outstanding reputation.

The latest monarch[®] series is writing the next chapter in this success story. The combination of state-of-the-art equipment and a compact design makes these powerful burners suitable for a wide range of applications.

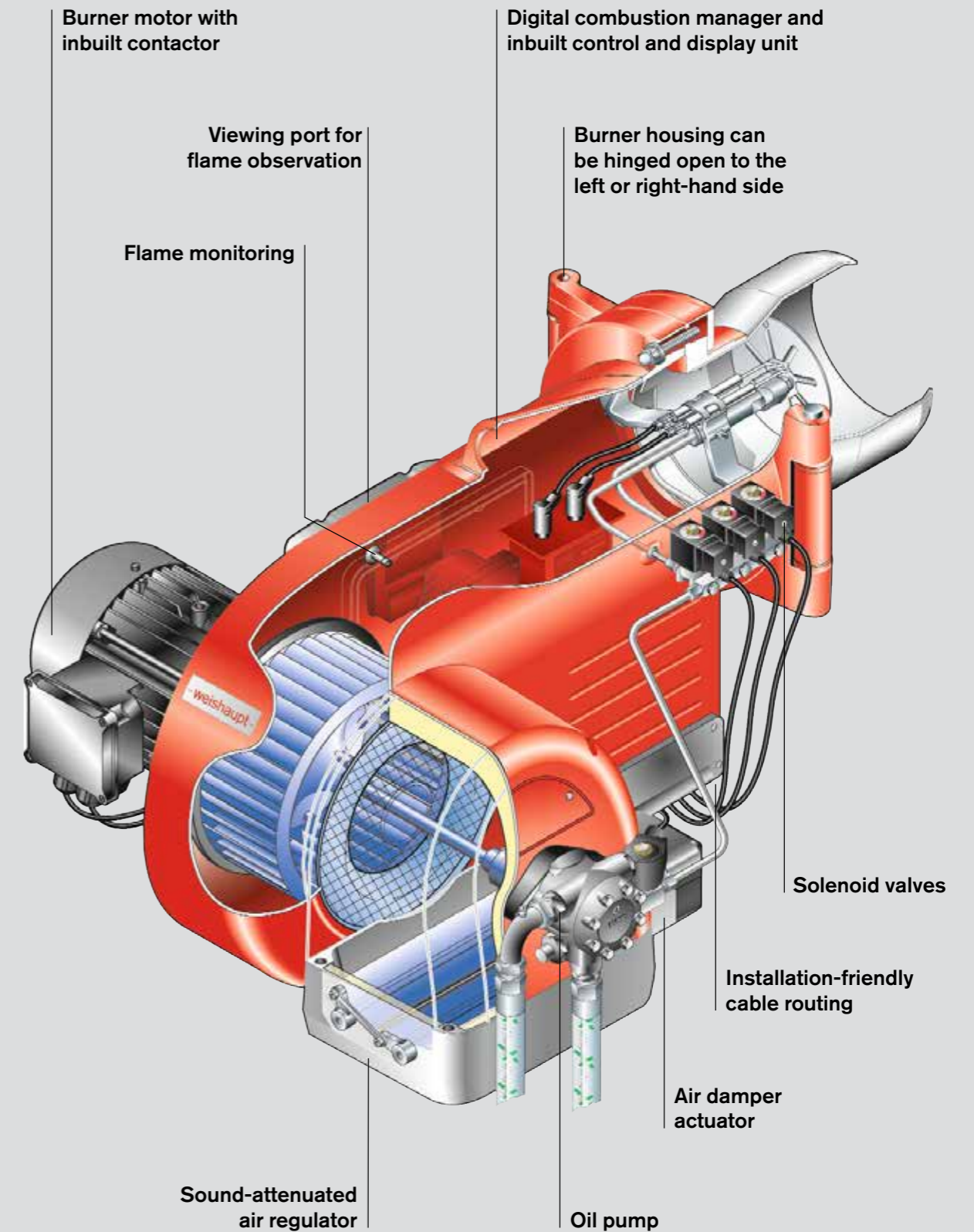

WM-L 20 version T

Digital

Digital combustion management means optimal combustion figures, continuously reproducible setpoints, and ease of use.

Weishaupt WM 20-series burners are equipped as standard with electronic compound regulation and digital combustion management. Modern combustion technologies demand a precise and continually reproducible dosing of fuel and combustion air. This optimises combustion efficiency and saves fuel.

Simple operation

Setting and control of the burner is achieved using a control and display unit. This is linked to the combustion manager via a bus system, enabling the user-friendly setting of the burner.

Flexible communication options

The integrated interface enables all necessary data and functions to be relayed to a master control system. If required, a modem can be installed to allow for remote operation, monitoring, and diagnosis.

Bus communication with external controls and building management

Several bus systems are available if data from the burner are to be exchanged with a PLC unit, or if control of the burner is to be integrated with a building management system.

For the control and management levels, Weishaupt offers ProGraf NT, a real-time software product that meets any and all requirements.

Technological edge

Digital combustion management makes burner operation simple and reliable. The most important advantages:

- No additional burner controls are necessary as control is effected by the combustion manager. The only additional requirements are a motor protection switch for the burner motor and external control fuses.
- Reduced installation expense. Each burner is factory tested and supplied as a complete unit.
- Commissioning and servicing takes less time. The burner's basic parameters are set at the factory. The combustion manager's menu-driven commissioning program is used to run through the final site-specific adjustments and the combustion emission checks.

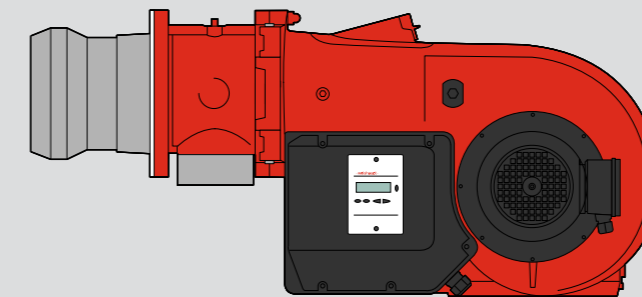

Burner with digital combustion management

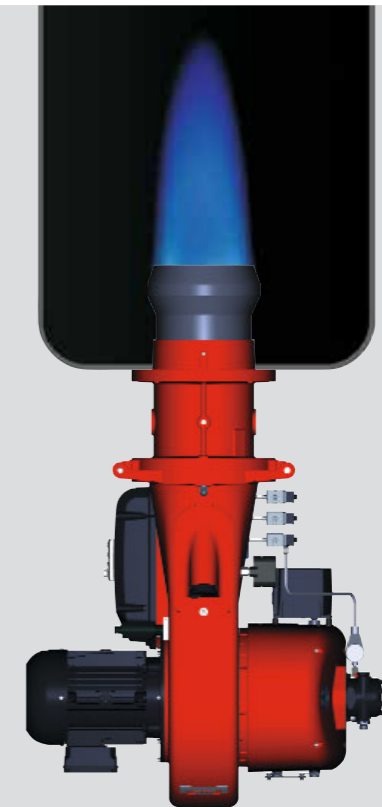

Digital combustion management Features	W-FM 50	W-FM 54	W-FM 100	W-FM 200
Single-fuel operation	●	–	●	●
Dual-fuel operation	–	●	●	●
Intermittent firing	●	●	●	●
Continuous firing >24 h	● ²⁾	–	●	●
Flame sensor for intermittent firing	ION/QRA2/QRB	QRA2	ION/QRI/QRB/QRA	ION/QRI/QRB/QRA
Flame sensor for continuous firing	ION	–	ION/QRI/QRA 73	ION/QRI/QRA 73
Maximum number of actuators	2	3	4	6
Actuators with stepping motors	●	●	●	●
VSD available	●	●	–	●
O ₂ trim available	–	–	–	●
Gas valve proving	●	●	●	●
4–20 mA input signal	●	●	○	●
Integrated, self-checking PID controller for temperature or pressure, 0 / 2–10 V and 0 / 4–20 mA included	–	–	○	●
Removable ABE control unit (max. length of connecting line)	20 m	20 m	100 m	100 m
Fuel consumption meter (switchable)	● ¹⁾	● ¹⁾	–	●
Combustion efficiency display in conjunction with O ₂ trim	–	–	–	●
eBUS / Modbus RTU interface	●	●	●	●
PC-supported commissioning	●	●	●	●

● Standard
○ Optional

Please enquire regarding connections available for additional functions, e.g. flue gas dampers, oil shutoff assemblies, etc.

¹⁾ Not in conjunction with VSD

²⁾ Gas burner with ionisation probes only

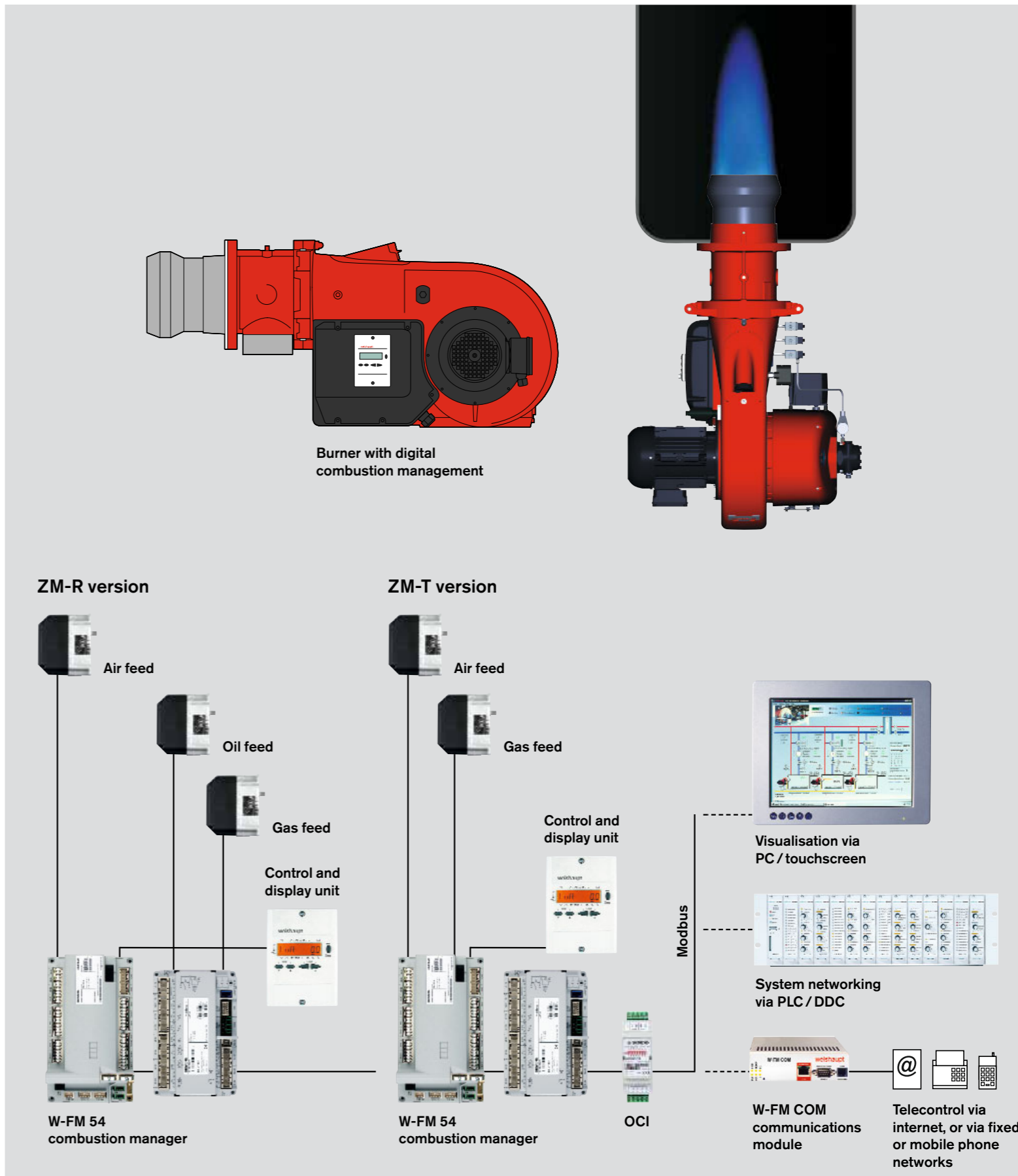

Schematic representation with W-FM 54

Compact and quiet

The latest Weishaupt WM-series monarch® burners are compact, powerful, and quiet. They are writing the next chapter in the 60-year-long success story of the legendary monarch® series.

Futuristic fan technology

From the very earliest stages of burner development, particular emphasis was placed on a compact, aerodynamic design and low operational noise levels.

To realise this goal a completely new air inlet and air damper control were developed. This special housing design with its self-opening air inlet and the new air-damper technology result in increased fan pressure and thus in greater capacity despite the burner's more compact form.

Air damper control provides a high degree of linearity even at the lower end of the burner's operating range and, combined with the sound-attenuated air inlet which is included as standard, ensures quieter operation.

Fast commissioning, simple servicing

All WM 20 burners are delivered with the mixing assembly preset for the required output of the burner. A final adjustment is made using the combustion manager's menu-controlled commissioning program.

All of the burner's components, such as the mixing assembly, air damper, and combustion manager, are readily accessible despite its compact form. This enables maintenance and servicing work to be carried out quickly and easily, aided by the standard hinged flange which provides a perfect servicing position.

Adjustment to suit different combustion chamber conditions can easily be made with the burner in its installed position. The integral sightglass enables ignition behaviour and the flame to be observed.

Control

The following methods of regulation are available for Weishaupt WM 20 burners:

Gas: Sliding-two-stage or modulating (ZM), depending on the method of load control employed.

Oil: Three-stage or two-stage with low-impact start or changeover (T). Sliding-two-stage or modulating (R), depending on the method of load control employed.

The output of a modulating burner is matched – within its operating range – to current heat demand.

These multiple control options make the burner suitable for a wide range of applications and ensure a gentle and problem-free start up, along with a high degree of operational reliability.

Various burner versions are available to meet differing emission limits and operational requirements:

ZM version

Burners with the standard, advanced-design mixing assembly for installations with Class 2 oil and gas-side NO_x emission limits.

LN version

Low-NO_x gas burners for installations with Class 3 NO_x emission limits. The reduction in NO_x is achieved through a more intensive recirculation of the combustion gases in the combustion chamber. Good emissions depend on combustion chamber geometry, thermal loading and on the combustion system (three-pass or reverse-flame).

ZMI version

Gas burners with an extended turndown range for special industrial applications.

3LN version

Low-NO_x gas, oil, and dual-fuel burners with multiflam® mixing assemblies that generate emissions below Class 3 NO_x limits for both gas and oil. The burners' very low NO_x emissions are achieved using a special fuel distribution system. 3LN-version burners can fire natural gas, LPG, or light oil, and are suitable for use on three-pass and through-pass boilers.

Reduced NO_x emissions with flue gas recirculation (gas burners)

Where stringent emission limits for oxides of nitrogen are in force, Weishaupt's multiflam® mixing assemblies for gas-fired burners can be combined with flue gas recirculation. Weishaupt takes advantage of the special properties of the flame geometry, and with it the adaptation to the combustion chamber, to reduce NO_x levels.

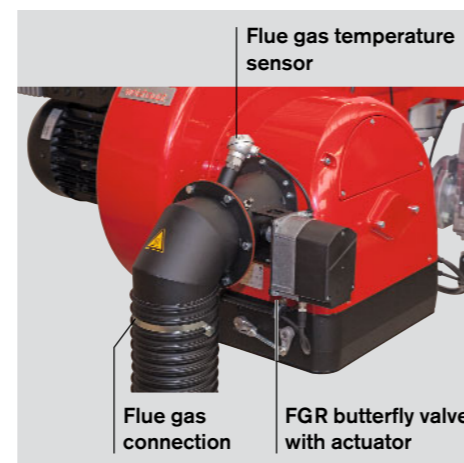

Air inlet housing with factory-preassembled flue gas recirculation components

Fuels

Natural gas
LPG
Light oil (35 s gas oil)
10 % biodiesel blends (B10)

The suitability of fuels of differing quality must be confirmed in advance with Weishaupt.

Applications

Weishaupt WM 20 burners are suitable for intermittent firing and continuous firing on:

- EN 303-compliant heat generators
- LTHW boilers
- HTHW boilers
- Steam boilers
- Air heaters
- Certain process applications

Permissible ambient conditions

- Ambient temperature
-15 to +40 °C for gas firing
-10 to +40 °C for oil firing
- Maximum 80 % relative humidity, no condensation
- The combustion air must be free of aggressive substances (halogens, chlorides, fluorides etc.) and impurities (dust, debris, vapours, etc.)
- Adequate ventilation is required for operation in enclosed spaces
- For plant in unheated areas, certain further measures may be required

Use of the burner for other applications or in ambient conditions not detailed above is not permitted without the prior written agreement of Max Weishaupt GmbH. Service intervals will be reduced in accordance with the more extreme operational conditions.

Protection Class

IP 54 per EN 60529.

Standards compliance

The burners are tested by an independent body and fulfil the applicable requirements of the following European Union directives and applied standards:

- EMC** EMC Directive 2014/30/EU
Applied standards:
▪ EN 61000-6-1 : 2007
▪ EN 61000-6-2 : 2005
▪ EN 61000-6-4 : 2007
- LVD** Low Voltage Directive 2014/35/EU
Applied standards:
▪ EN 60335-1 : 2010
▪ EN 60335-2-102 : 2010
- MD** Machinery Directive 2006/42/EC
Applied standards:
▪ EN 267 Annex J,
▪ EN 676 Annex J,
- GAD** Gas Appliance Directive 2009/142/EC
Applied standards:
▪ EN 676 : 2008
- PED¹⁾** Pressure Equipment Directive 2014/68/EU
Applied standards:
▪ EN 267 Annex K,
▪ EN 676 Annex K,
▪ Conformity assessment procedure: Module B

The burners are labelled with

- CE Mark,
- CE-PIN per 2009/142/EC
- Identification No. of the notified body

¹⁾ With the appropriate choice of equipment.

The most important advantages:

- Easy changeover between gas and oil on dual-fuel burners
- Digital combustion management with electronic compound regulation at all ratings
- Compact design
- Sound-attenuated air inlet as standard for quieter operation
- Powerful fan with specially developed fan geometry and air damper control
- All WM 20 burners are delivered with the mixing assembly preset for the required output of the burner
- IP 54 protection as standard
- Easy access to all components, such as the mixing assembly, air damper and combustion manager
- Reliable operation with three-stage, sliding-two-stage, or modulating operation, depending on the burner version and method of load control
- Computer-controlled function test of each individual burner at the factory
- Burners can be supplied with pre-wired plug connections
- Excellent price / capacity relationship
- Well-established, global service network

Trademark protection

Weishaupt WM 20 monarch® burners are registered as a Community Trade Mark throughout Europe.

Overview of burner control

Model designation

Oil-fired operation

Three-stage control (T)

- Oil is released during start up by the opening of solenoid valve 1 and the safety solenoid valve.
- Full load is reached by the opening of solenoid valves 2 and 3.
- Load control is achieved by opening and closing solenoid valves 2 and 3.

Sliding-two-stage or modulating control (R)

- On opening the solenoid valves the correct rate of oil for start up is released.
- An actuator sets the oil regulator to full load.
- Load control is achieved through the opening and closing of the oil regulator.
- Modulating operation:
 - W-FM 50 or W-FM 54 with KS20 controller
 - W-FM 100 with load controller
 - W-FM 200
- Alternatively, a PID controller can be fitted into the control panel

Three-stage

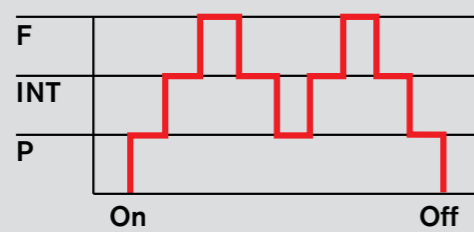

Sliding-two-stage

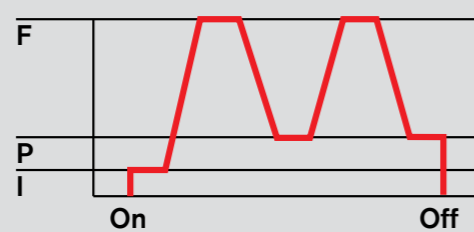

Modulating

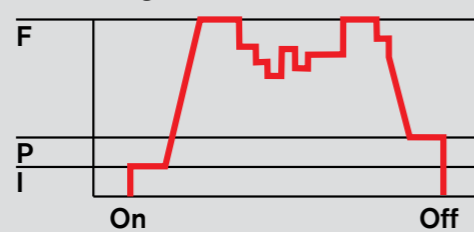

Gas-fired operation

Sliding-two-stage or modulating control (ZM)

- Actuators drive the burner to partial load or full load in response to heat demand.
- There is a gradual change between both load points. There are no sudden, large changes in fuel throughput.
- Modulating operation:
 - W-FM 50 or W-FM 54 with KS20 controller
 - W-FM 100 with load controller
 - W-FM 200
- Alternatively, a PID controller can be fitted into the control panel

F = Full load (nominal load)
 INT = Intermediate load
 P = Partial load (minimum load)
 I = Ignition load

Burner selection

WM-L20, versions T and R

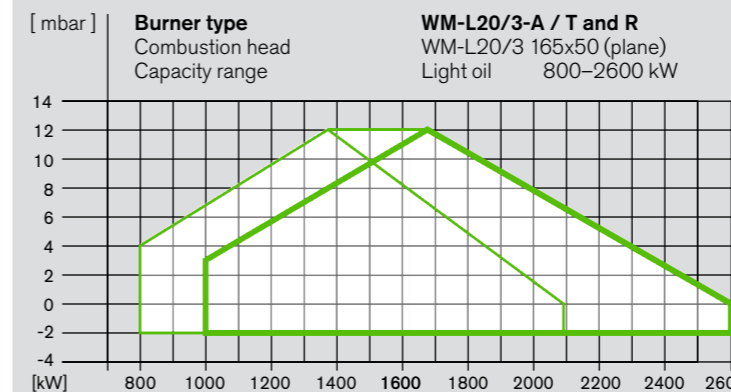
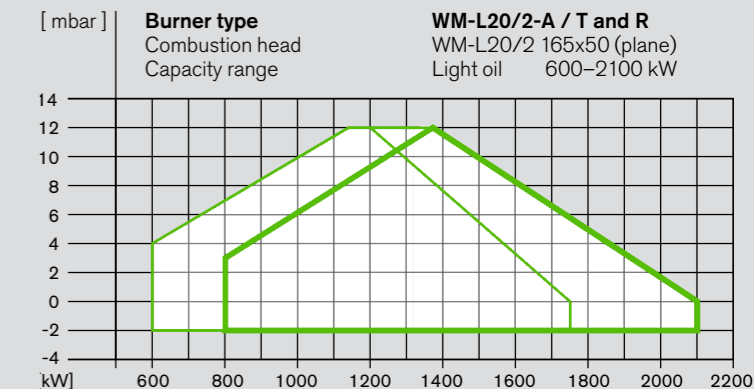
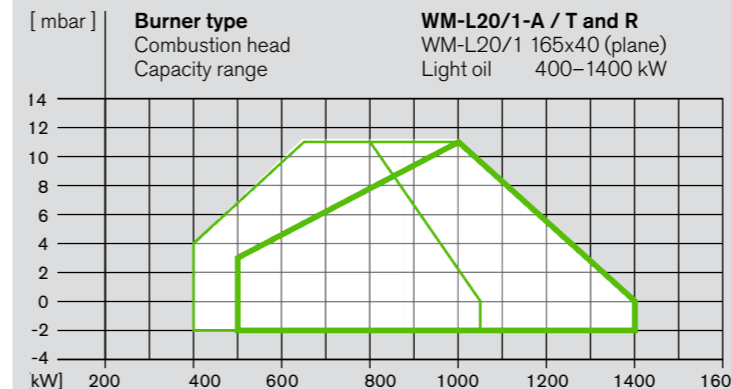

Light oil: Capacity with combustion head
 Closed
 Open

Capacity graphs for oil burners certified in accordance with EN 267.

Stated ratings are based on an air temperature of 20 °C and an installation altitude of 500 m above sea level.

Stated oil throughputs are based on a nett calorific value (LHV) of 11.9 kWh/kg.

DIN CERTCO certification:
 The burners have been type-tested by an independent body (TÜV-Süd) and certified by DIN CERTCO.

Fuel Version	Oil			Gas	
	three-stage	sliding-two-stage	modulating	sliding-two-stage	modulating
ZM				●	●
ZM-T	●			●	●
ZM-R		●	●	●	●

Model designation

WM - L 20 / 3 -A T ...R

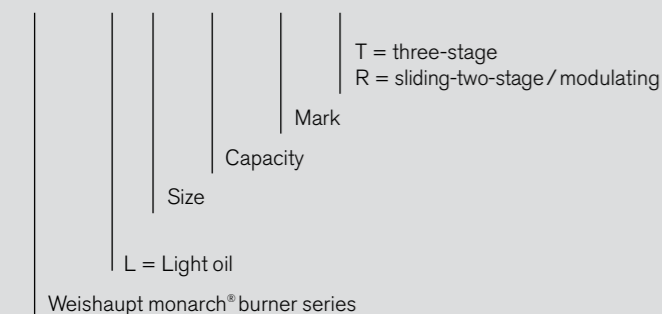

WM - GL 20 / 3 -A ZM - T ...ZM-R

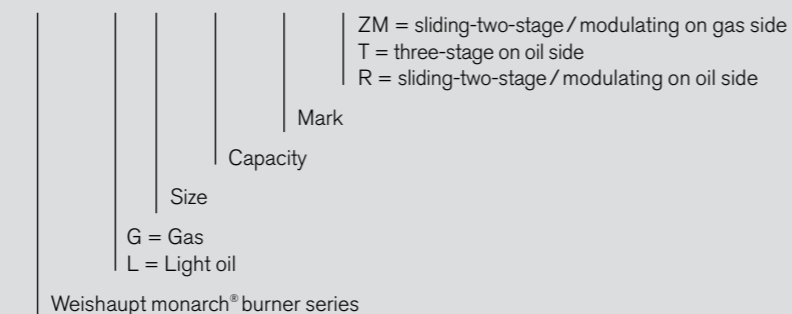

Burner selection WM-G20, version ZM

Gas valve train sizing WM-G20, version ZM

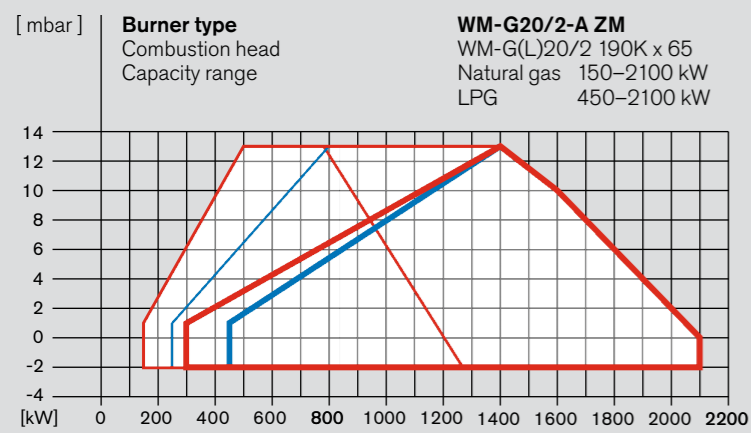

Nat. gas: Capacity with comb. head
Closed —
Open —

LPG: Capacity with comb. head
Closed —
Open —

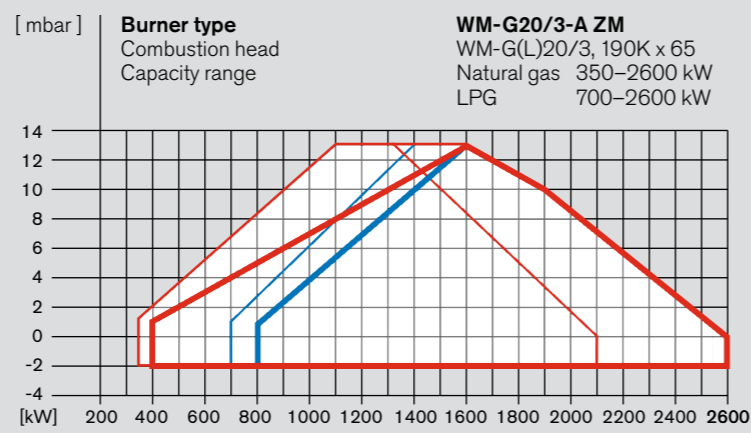

Capacity graphs for gas and dual-fuel burners certified in accordance with EN 676 and EN 267.

Stated ratings are based on an air temperature of 20 °C and an installation at sea level. For installations at higher altitudes, a reduction in capacity of 1 % per 100 m above sea level should be taken into account.

WM-G20/2-A, version ZM

Burner rating kW	Low-pressure supply (with FRS) (flow pressure in mbar into shut-off valve, $P_1 \leq 300$ mbar)						High-pressure supply (with HP regulator) (flow pressure in mbar into gas valve assembly)					
	Nominal valve train diameter						Nominal valve train diameter					
	1" 1½"	2"	65	80	100	125	1" 1½"	2"	65	80	100	125
	Nominal diameter of gas butterfly						Nominal diameter of gas butterfly					
	65	65	65	65	65	65	65	65	65	65	65	65

Natural gas E LHV = 10.35 kWh/Nm ³ ; d = 0.606												
500	28	-	-	-	-	-	7	-	-	-	-	-
700	54	21	-	-	-	-	14	10	-	-	-	-
900	87	33	13	-	-	-	23	16	6	-	-	-
1100	129	47	19	11	-	-	35	24	9	5	-	-
1300	178	65	25	14	10	-	48	34	12	7	6	-
1500	236	85	31	18	13	10	64	44	15	9	7	6
1800	-	122	44	25	17	13	92	64	22	13	11	9
2100	-	164	59	33	22	17	125	87	30	18	14	12

Natural gas LL LHV = 8.83 kWh/Nm ³ ; d = 0.641												
500	40	16	-	-	-	-	10	7	-	-	-	-
700	77	29	12	-	-	-	21	14	5	-	-	-
900	126	47	19	11	-	-	34	24	9	6	-	-
1100	186	68	26	16	11	9	51	36	13	8	7	6
1300	259	94	35	20	14	11	70	49	17	11	9	8
1500	-	123	45	25	18	14	93	65	23	14	11	9
1800	-	177	65	36	25	19	135	94	33	21	17	14
2100	-	239	87	48	33	25	182	127	45	28	22	19

LPG* LHV = 25.89 kWh/Nm ³ ; d = 1.555												
500	13	-	-	-	-	-	5	-	-	-	-	-
700	24	-	-	-	-	-	6	-	-	-	-	-
900	38	15	-	-	-	-	10	7	-	-	-	-
1100	55	21	-	-	-	-	15	10	-	-	-	-
1300	75	29	12	-	-	-	20	14	5	-	-	-
1500	99	37	15	-	-	-	27	19	7	-	-	-
1800	141	52	20	12	9	-	38	27	10	6	5	-
2100	192	70	27	16	12	9	52	37	13	8	7	6

* The LPG charts are based on propane, but may also be used for butane.

Screwed		Flanged	
R 1	W-MF 512	DN 65	DMV 5065/12
R 1½	W-MF 512	DN 80	DMV 5080/12
R 2	DMV 525/12	DN 100	DMV 5100/12
		DN 125	VDG 40.125

Stated flow pressures are based on a combustion chamber resistance of 0 mbar. The combustion chamber pressure of the heat generator must be added to the figure determined from the above chart when sizing the gas valve train. Minimum flow pressure 15 mbar.

For low-pressure supplies, EN 88-compliant governors with safety diaphragms are used.

For high-pressure supplies, an EN 334-compliant high-pressure regulator should be selected from the following technical booklets:

- Regulators up to 4 bar, Print No. 83001202
- Regulators with safety devices, Print No. 83197902

Refer to the burner's rating plate for the maximum connection pressure.

WM-G20/3-A, version ZM

Burner rating kW	Low-pressure supply (with FRS) (flow pressure in mbar into shut-off valve, $P_1 \leq 300$ mbar)						High-pressure supply (with HP regulator) (flow pressure in mbar into gas valve assembly)					
	Nominal valve train diameter						Nominal valve train diameter					
	1" 1½"	2"	65	80	100	125	1" 1½"	2"	65	80	100	125
	Nominal diameter of gas butterfly						Nominal diameter of gas butterfly					
	65	65	65	65	65	65	65	65	65	65	65	65

Natural gas E LHV = 10.35 kWh/Nm ³ ; d = 0.606												
1100	129	47	19	11	8	-	35	24	9	5	-	-
1300	179	65	25	15	11	9	48	34	12	7	6	5
1500	237	86	32	18	13	10	64	45	16	10	8	7
1700	-	109	40	23	16	12	82	57	20	12	10	8
1900	-	135	49	27	19	14	102	71	25	15	12	10
2100	-	165	60	33	23	17	125	87	30	18	15	12
2300	-	197	71	39	26	20	154	104	36	22	17	14
2600	-	250	89	48	32	24	201	132	45	27	22	18

Natural gas LL LHV = 8.83 kWh/Nm ³ ; d = 0.641												
1100	186	68	26	15	11	9	50	35	12	8	6	5
1300	258	93	35	20	14	11	70	49	17	11	9	7
1500	-	123	45	25	18	14	93	65	23	14	11	9
1700	-	157	57	31	21	16	119	83	28	17	14	11
1900	-	195	70	38	26	19	150	103	35	21	17	14
2100	-	238	85	46	31	23	201	126	43	26	21	17
2300	-	284	101	55	37	27	261	151	51	31	25	20
2600	-	361	128	68	45	33	401	191	65	39	31	25

LPG* LHV = 25.89 kWh/Nm ³ ; d = 1.555												
1100	55	21	-	-	-	-	15	10	-	-	-	-
1300	75	29	12	-	-	-	20	14	5	-	-	-
1500	99	37	15	-	-	-	27	19	7	-	-	-
1700	126	46	18	11	8	-	34	24	8	5	-	-
1900	157	57	22	13	10	-	43	30	11	7	5	-
2100	191	70	27	16	12	9	52	36	13	8	7	6
2300	229	83	32	18	13	11	62	44	16	10	8	7
2600	292	106	40	23	16	13	80	56	20	13	10	9

Burner selection

WM-G20, version ZM-LN

Gas valve train sizing

WM-G20, version ZM-LN

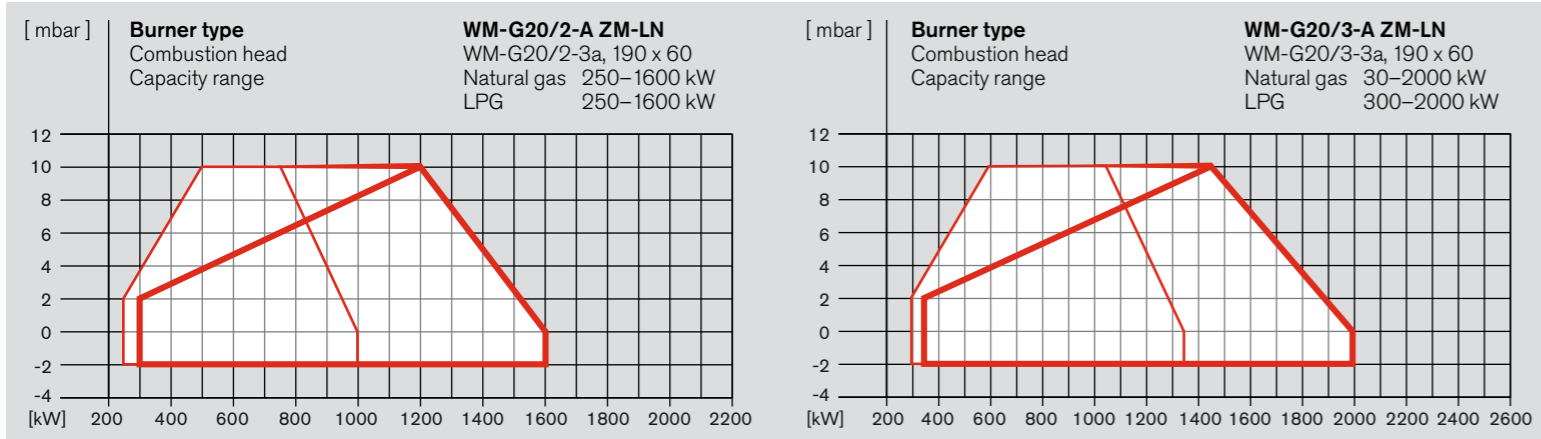

Natural gas and LPG: Capacity with combustion head
 Closed —
 Open - - -

Capacity graphs for gas and dual-fuel burners certified in accordance with EN 676 and EN 267.

Stated ratings are based on an air temperature of 20 °C and an installation at sea level. For installations at higher altitudes, a reduction in capacity of 1 % per 100 m above sea level should be taken into account.

WM-G20/2-A, version ZM-LN

Burner rating kW	Low-pressure supply (with FRS) (flow pressure in mbar into shut-off valve, $P_1 \leq 300$ mbar)					High-pressure supply (with HP regulator) (flow pressure in mbar into gas valve assembly)				
	1" 1/2"	2"	65	80	100 125	1" 1/2"	2"	65	80	100 125
	Nominal diameter of gas butterfly					Nominal diameter of gas butterfly				
	65	65	65	65	65 65	65	65	65	65	65 65

Natural gas E LHV = 10.35 kWh/Nm³; d = 0.606

500	33	16	10	9	8	-	-	11	9	6	5	5	5	5
600	45	21	13	11	10	9	9	16	13	8	7	7	7	6
700	60	27	15	13	11	11	11	21	16	10	9	8	8	8
800	77	34	18	15	13	12	12	26	20	12	10	10	9	9
900	95	41	22	17	15	14	14	32	25	14	12	11	11	11
1000	116	49	25	19	17	15	15	38	29	16	14	13	12	12
1100	139	58	29	21	19	17	17	45	34	19	16	15	14	14
1200	163	66	32	23	20	18	18	52	39	21	17	16	15	15
1400	218	87	40	28	23	21	20	68	51	25	20	19	17	17
1600	282	110	49	33	27	24	23	86	63	30	24	21	20	20

Natural gas LL LHV = 8.83 kWh/Nm³; d = 0.641

500	45	20	12	9	8	-	-	15	11	7	6	6	5	5
600	63	27	15	12	10	10	10	20	16	9	8	7	7	7
700	83	36	19	14	13	12	11	27	21	12	10	9	9	9
800	107	45	23	17	15	14	13	34	26	14	12	11	11	10
900	134	55	27	20	17	16	15	43	32	17	14	13	12	12
1000	164	66	32	23	19	17	17	51	39	20	16	15	14	14
1100	197	78	36	26	22	19	19	61	46	23	18	17	16	16
1200	232	91	41	29	24	21	20	71	53	26	20	19	18	17
1400	-	120	52	35	28	25	24	94	69	32	25	22	21	20
1600	-	153	64	42	33	29	27	119	87	39	29	26	24	24

LPG* LHV = 25.89 kWh/Nm³; d = 1.555

500	17	10	-	-	-	-	-	7	6	-	-	-	-	-
600	23	13	9	8	8	-	-	9	8	6	6	5	5	5
700	30	16	11	10	10	9	9	12	10	7	7	7	7	7
800	37	19	13	12	11	11	11	15	12	9	8	8	8	8
900	45	23	15	13	12	12	12	18	15	11	10	10	9	9
1000	55	27	17	15	14	13	13	21	18	12	11	11	11	11
1100	65	31	20	17	15	15	15	25	20	14	13	12	12	12
1200	75	35	21	17	16	15	15	28	23	15	13	13	13	12
1400	98	44	24	20	18	17	16	34	27	17	15	14	14	14
1600	124	53	28	22	19	18	18	42	33	19	17	16	15	15

* The LPG charts are based on propane, but may also be used for butane.

Screwed		Flanged	
R 1	W-MF 512	DN 65	DMV 5065/12
R 1 1/2	W-MF 512	DN 80	DMV 5080/12
R 2	DMV 525/12	DN 100	DMV 5100/12
		DN 125	VDG 40.125

Stated flow pressures are based on a combustion chamber resistance of 0 mbar. The combustion chamber pressure of the heat generator must be added to the figure determined from the above chart when sizing the gas valve train. Minimum flow pressure 15 mbar.

For low-pressure supplies, EN 88-compliant governors with safety diaphragms are used.

For high-pressure supplies, an EN 334-compliant high-pressure regulator should be selected from the following technical booklets:

- Regulators up to 4 bar, Print No. 83001202
- Regulators with safety devices, Print No. 83197902

Refer to the burner's rating plate for the maximum connection pressure.

WM-G20/3-A, version ZM-LN

Burner rating kW	Low-pressure supply (with FRS) (flow pressure in mbar into shut-off valve, $P_1 \leq 300$ mbar)					High-pressure supply (with HP regulator) (flow pressure in mbar into gas valve assembly)				
	1" 1/2"	2"	65	80	100 125	1" 1/2"	2"	65	80	100 125
	Nominal diameter of gas butterfly					Nominal diameter of gas butterfly				
	65	65	65	65	65 65	65	65	65	65	65 65

Natural gas E LHV = 10.35 kWh/Nm³; d = 0.606

600	44	20	11	9	-	-	-	14	11	6	5	5	-	-
700	58	25	14	11	10	9	9	19	15	8	7	7	6	6
800	75	32	17	13	11	11	10	24	19	10	9	8	8	8
900	94	39	20	15	13	12	12	30	23	13	10	10	9	9
1000	115	47	23	17	15	14	13	36	28	15	12	11	11	11
1200	162	65	31	22	19	17	16	51	38	20	16	15	14	14
1400	218	86	39	28	23	20	20	67	50	25	20	18	17	17
1600	281	109	48	33	27	23	22	85	63	30	23	21	20	19
1800	-	135	58	38	31	26	25	105	77	35	27	24	22	22
2000	-	163	68	44	35	30	28	127	93	41	30	27	25	24

Natural gas LL LHV = 8.83 kWh/Nm³; d = 0.641

600	61	25	13	10	9	-	-	19	14	7	6	5	5	5
700	82	34	17	12	11	10	10	25	19	10	8	7	7	7
800	105	43	21	15	13	12	11	33	25	13	10	9	9	9
900	132	53	25	18	15	14	13	41	31	15	12	11	11	10
1000	162	64	30	21	18	16	15	50	37	18	14	13	12	12
1200	231	90	40	27	22	20	19	70	52	25	19	17	16	16
1400	-	119	51	34	28	24	23	93	68	31	24	22	20	20
1600	-	152	64	41	33	28	26	119	87	38	29	26	23	23
1800	-	190	77	49	38	32	30	-	107	46	33	30	27	26
2000	-	231	92	57	43	36	34	-	129	54	39	34	31	30

LPG* LHV = 25.89 kWh/Nm³; d = 1.555

600	21	11	-	-	-	-	-	8	6	-	-	-	-	-
700	28	14	10	8	-	-	-	10	8	6	5	5	-	-
800	35	18	11	10	9	9	9	13	11	7	7	6	6	6
900	43	21	13	11	10	10	10	16	13	9	8	8	7	7
1000	53	25	15	13	12	11	11	19	15	10	9	9	9	8
1200	73	33	19	16	14	14	13	26	21	13	12	11	11	11
1400	97	43	24	19	17	16	16	34	27	16	14	14	13	13
1600	124	53	28	22	19	18	17	42	33	19	16	15	15	15
1800	153	64	32	24	21	19	19	50	39	22	18	17	16	16
2000	186	76	37	27	23	21	21	60	46	24	20	19	18	18

Burner selection

WM-GL20, versions ZM-T and ZM-R

Gas valve train sizing

WM-GL20, versions ZM-T and ZM-R

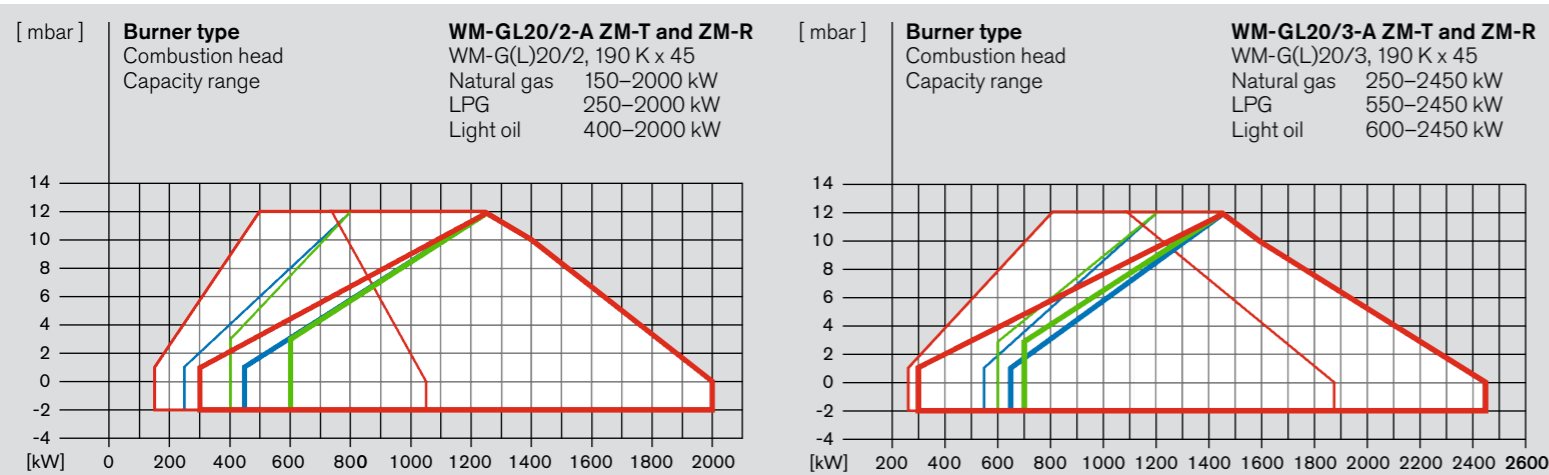

Nat. gas: Capacity with comb. head
 Closed ▬ Open ▬
LPG: Capacity with comb. head
 Closed ▬ Open ▬
Light oil: Capacity with comb. head
 Closed ▬ Open ▬

Capacity graphs for gas and dual-fuel burners certified in accordance with EN 676 and EN 267.

Stated ratings are based on an air temperature of 20 °C and an installation at sea level. For installations at higher altitudes, a reduction in capacity of 1 % per 100 m above sea level should be taken into account.

WM-GL20/2-A, versions ZM-T and ZM-R

Burner rating kW	Low-pressure supply (with FRS) (flow pressure in mbar into shut-off valve, P ₁ ≤ 300 mbar)						High-pressure supply (with HP regulator) (flow pressure in mbar into gas valve assembly)					
	Nominal valve train diameter						Nominal valve train diameter					
	1" 1½"	2"	65	80	100	125	1" 1½"	2"	65	80	100	125
	Nominal diameter of gas butterfly						Nominal diameter of gas butterfly					
	65	65	65	65	65	65	65	65	65	65	65	65

Burner rating kW	Natural gas E LHV = 10.35 kWh/Nm ³ ; d = 0.606						Natural gas LL LHV = 8.83 kWh/Nm ³ ; d = 0.641								
	500	700	900	1100	1300	1500	1750	2000	500	700	900	1100	1300	1500	1750

Burner rating kW	LPG* LHV = 25.89 kWh/Nm ³ ; d = 1.555						LPG* LHV = 25.89 kWh/Nm ³ ; d = 1.555								
	500	700	900	1100	1300	1500	1750	2000	500	700	900	1100	1300	1500	1750

Burner rating kW	Natural gas E LHV = 10.35 kWh/Nm ³ ; d = 0.606						Natural gas LL LHV = 8.83 kWh/Nm ³ ; d = 0.641								
	800	1000	1200	1400	1600	1800	2100	2450	800	1000	1200	1400	1600	1800	2100

* The LPG charts are based on propane, but may also be used for butane.

Screwed		Flanged	
R 1	W-MF 512	DN 65	DMV 5065/12
R 1½	W-MF 512	DN 80	DMV 5080/12
R 2	DMV 525/12	DN 100	DMV 5100/12
		DN 125	VG 40.125

Stated flow pressures are based on a combustion chamber resistance of 0 mbar. The combustion chamber pressure of the heat generator must be added to the figure determined from the above chart when sizing the gas valve train. Minimum flow pressure 15 mbar.

For low-pressure supplies, EN 88-compliant governors with safety diaphragms are used.

For high-pressure supplies, an EN 334-compliant high-pressure regulator should be selected from the following technical booklets:

- Regulators up to 4 bar, Print No. 83001202
- Regulators with safety devices, Print No. 83197902

Refer to the burner's rating plate for the maximum connection pressure.

WM-GL20/3-A, versions ZM-T and ZM-R

Burner rating kW	Low-pressure supply (with FRS) (flow pressure in mbar into shut-off valve, P ₁ ≤ 300 mbar)						High-pressure supply (with HP regulator) (flow pressure in mbar into gas valve assembly)					
	Nominal valve train diameter						Nominal valve train diameter					
	1" 1½"	2"	65	80	100	125	1" 1½"	2"	65	80	100	125
	Nominal diameter of gas butterfly						Nominal diameter of gas butterfly					
	65	65	65	65	65	65	65	65	65	65	65	65

Burner rating kW	Natural gas E LHV = 10.35 kWh/Nm ³ ; d = 0.606						Natural gas LL LHV = 8.83 kWh/Nm ³ ; d = 0.641								
	800	1000	1200	1400	1600	1800	2100	2450	800	1000	1200	1400	1600	1800	2100

Burner rating kW	LPG* LHV = 25.89 kWh/Nm ³ ; d = 1.555						LPG* LHV = 25.89 kWh/Nm ³ ; d = 1.555								
	800	1000	1200	1400	1600	1800	2100	2450	800	1000	1200	1400	1600	1800	2100

Burner rating kW	Natural gas E LHV = 10.35 kWh/Nm ³ ; d = 0.606						Natural gas LL LHV = 8.83 kWh/Nm ³ ; d = 0.641								
	800	1000	1200	1400	1600	1800	2100	2450	800	1000	1200	1400	1600	1800	2100

Scope of delivery

Description	WM-L20 T	WM-L20 R	WM-G20 ZM / LN	WM-GL20 ZM-T	WM-GL20 ZM-R
Burner housing, hinged flange, housing cover, Weishaupt burner motor, air inlet housing, fan wheel, combustion head, ignition unit, ignition cable, ignition electrodes, combustion manager with control unit, flame sensor, actuators, flange gasket, limit switch on hinged flange, fixing screws	●	●	●	●	●
Digital combustion manager W-FM 50	●	●	●	-	-
W-FM 54	-	-	-	●	●
W-FM 100	○	○	○	○	○
Valve proving via the combustion manager	-	-	●	●	●
Class-A double gas valve assembly	-	-	●	●	●
Gas butterfly valve	-	-	●	●	●
Air pressure switch	○	○	●	●	●
Low gas pressure switch	-	-	●	●	●
Preset, capacity-based mixing assembly	●	●	●	●	●
Actuators for compound regulation of fuel and air via W-FM:					
Air damper actuator	●	●	●	●	●
Gas butterfly valve actuator	-	-	●	●	●
Oil regulator actuator	-	●	-	-	●
Oil pressure switch in return	-	●	-	-	●
Oil pump fitted to burner	●	●	-	●	●
Oil hoses	●	●	-	●	●
4 oil solenoid valves, oil regulator, nozzle head with premounted regulating nozzle	-	●	-	-	●
3 oil solenoid valves, 1 safety valve, three-stage nozzle head with preinstalled oil nozzles	●	-	-	●	-
Electromagnetic clutch	○	○	-	○	●
DOL motor contactor fitted to motor ¹⁾	●	●	●	●	●
IP 54 protection	●	●	●	●	●

EN 676 stipulates that ball valves, gas filters, and gas pressure regulators form part of the burner supply (see Weishaupt accessories list). Please enquire or see the special equipment section of this brochure for further burner executions.

- Standard
- Optional

¹⁾ The necessary motor protection can be provided either by a motor protection switch (supplied and fitted into a panel by others), or with integral motor overload protection (see special equipment).

Order numbers

Oil burners, version T

Burner type	Version	Order No.
WM-L20/1-A	T	211 210 10
WM-L20/2-A	T	211 210 20
WM-L20/3-A	T	211 210 30

DIN CERTCO: 5G1031/12

Gas burners, version ZM

Burner type	Version	Valve train size	Order No.
WM-G20/2-A	ZM	R 1	217 211 11
	ZM	R 1 ½	217 211 12
	ZM	R 2	217 211 13
	ZM	DN 65	217 211 14
	ZM	DN 80	217 211 15
	ZM	DN 100	217 211 16
	ZM	DN 125	217 211 17
WM-G20/3-A	ZM	R 1	217 213 11
	ZM	R 1 ½	217 213 12
	ZM	R 2	217 213 13
	ZM	DN 65	217 213 14
	ZM	DN 80	217 213 15
	ZM	DN 100	217 213 16
	ZM	DN 125	217 213 17

CE-PIN: CE 0085BS0032

Gas burners, version ZM-LN

Burner type	Version	Valve train size	Order No.
WM-G20/2-A	ZM-LN	R 1	217 212 11
	ZM-LN	R 1 ½	217 212 12
	ZM-LN	R 2	217 212 13
	ZM-LN	DN 65	217 212 14
	ZM-LN	DN 80	217 212 15
	ZM-LN	DN 100	217 212 16
	ZM-LN	DN 125	217 212 17
WM-G20/3-A	ZM-LN	R 1	217 214 11
	ZM-LN	R 1 ½	217 214 12
	ZM-LN	R 2	217 214 13
	ZM-LN	DN 65	217 214 14
	ZM-LN	DN 80	217 214 15
	ZM-LN	DN 100	217 214 16
	ZM-LN	DN 125	217 214 17

CE-PIN: CE 0085BS0032

Oil burners, version R

Burner type	Version	Order No.
WM-L20/1-A	R	215 210 10
WM-L20/2-A	R	215 210 20
WM-L20/3-A	R	215 210 30

DIN CERTCO: 5G1031/12

Dual-fuel burners, version ZM-T

Burner type	Version	Valve train size	Order No.
WM-GL20/2-A	ZM-T	R 1	218 212 11
	ZM-T	R 1 ½	218 212 12
	ZM-T	R 2	218 212 13
	ZM-T	DN 65	218 212 14
	ZM-T	DN 80	218 212 15
	ZM-T	DN 100	218 212 16
	ZM-T	DN 125	218 212 17
WM-GL20/3-A	ZM-T	R 1	218 213 11
	ZM-T	R 1 ½	218 213 12
	ZM-T	R 2	218 213 13
	ZM-T	DN 65	218 213 14
	ZM-T	DN 80	218 213 15
	ZM-T	DN 100	218 213 16
	ZM-T	DN 125	218 213 17

DIN CERTCO: 5G1032/M
CE-PIN: CE - 0085BT0133

Dual-fuel burners, version ZM-R

Burner type	Version	Valve train size	Order No.
WM-GL20/2-A	ZM-R	R 1	218 215 11
	ZM-R	R 1 ½	218 215 12
	ZM-R	R 2	218 215 13
	ZM-R	DN 65	218 215 14
	ZM-R	DN 80	218 215 15
	ZM-R	DN 100	218 215 16
	ZM-R	DN 125	218 215 17
WM-GL20/3-A	ZM-R	R 1	218 216 11
	ZM-R	R 1 ½	218 216 12
	ZM-R	R 2	218 216 13
	ZM-R	DN 65	218 216 14
	ZM-R	DN 80	218 216 15
	ZM-R	DN 100	218 216 16
	ZM-R	DN 125	218 216 17

DIN CERTCO: 5G1032/M
CE-PIN: CE - 0085BT0133

Special equipment WM-L20, version T

Special equipment WM-L20, version R

Version T (three-stage)			WM-L20/1-A	WM-L20/2-A	WM-L20/3-A
Pressure gauge with ball valve			110 000 79	110 000 79	110 000 79
Vacuum gauge with ball valve			110 005 69	110 005 69	110 005 69
Combustion head extension	by 100 mm		210 030 49	210 030 52	210 030 55
	by 200 mm		210 030 50	210 030 53	210 030 56
	by 300 mm		210 030 51	210 030 54	210 030 57
Oil hoses, 1300 mm in lieu of 1000 mm			110 000 72	110 000 72	110 000 72
Two-stage operation with low-impact start or changeover			210 030 31	210 030 31	210 030 31
Air inlet flange for ducted-air connection, with LGW 10 air pressure switch (LGW 50 also required)			210 030 47	210 030 47	210 030 47
LGW 50 air pressure switch ²⁾			210 030 08	210 030 08	210 030 08
Oil meter	< 150 kg	VZO8 without transmitter	210 030 42	210 030 42	210 030 42
		VZO8 with low-frequency transmitter for external wiring	210 030 43	210 030 43	210 030 43
	> 150 kg	VZO20 without transmitter	210 030 44	210 030 44	210 030 44
		VZO20 with low-frequency transmitter for external wiring	210 030 45	210 030 45	210 030 45
ST 18/7 and ST 18/4 plug connections (W-FM 50 / 100 / 200)			210 030 13	210 030 13	210 030 13
ST 18/7 plug connection (W-FM 50 with KS20)			250 031 06	250 031 06	250 031 06
Burner-mounted KS20 controller (W-FM 50)			250 033 15	250 033 15	250 033 15
W-FM 100 (suitable for continuous firing) in lieu of W-FM 50 ²⁾			burner-mounted	210 030 32	210 030 32
			supplied loose	210 030 88	210 030 88
DSB 158 oil pressure switch in supply ²⁾			210 030 46	210 030 46	210 030 46
QRI flame sensor in lieu of QRB ²⁾			210 030 24	210 030 24	210 030 24
Integral load controller and analogue signal convertor for W-FM 100			110 017 18	110 017 18	110 017 18
W-FM 200 in lieu of W-FM 50, with integral load controller, analogue signal convertor, and VSD module, with optional fuel metering			burner-mounted	210 030 10	210 030 10
			supplied loose	Please enquire	Please enquire
WM-D112 motor with 230 V contactor and overload protection ¹⁾			250 030 95	250 030 95	250 030 95
ABE with Chinese-character display, supplied loose (W-FM 100 / 200)			110 018 53	110 018 53	110 018 53
Special voltage (on application only)			210 030 69	210 030 69	210 030 69
110 V control voltage			250 031 72	250 031 72	250 031 72

Country-specific executions and special voltages on application

¹⁾ The necessary motor protection can be provided either by a motor protection switch (supplied and fitted into a panel by others), or with integral motor overload protection (see special equipment).

²⁾ Required for PED (2014/68/EU) compliance.

Version R (sliding-two-stage or modulating)			WM-L20/1-A	WM-L20/2-A	WM-L20/3-A
Pressure gauge with ball valve on pump			110 002 82	110 002 82	110 002 82
Pressure gauge with ball valve in return			110 011 50	110 011 50	110 011 50
Vacuum meter with ball valve			Please enquire	Please enquire	Please enquire
Combustion head extension	by 100 mm		210 030 58	210 030 61	210 030 64
	by 200 mm		210 030 59	210 030 62	210 030 65
	by 300 mm		210 030 60	210 030 63	210 030 66
Oil hoses, 1300 mm in lieu of 1000 mm			110 001 59	110 001 59	110 001 59
Air inlet flange for ducted-air connection, with LGW 10 air pressure switch (LGW 50 also required)			210 030 47	210 030 47	210 030 47
LGW 50 air pressure switch ²⁾			210 030 08	210 030 08	210 030 08
ST 18/7 and ST 18/4 plug connections (W-FM 50 / 100 / 200)			210 030 13	210 030 13	210 030 13
ST 18/7 plug connection (W-FM 50 with KS20)			250 031 06	250 031 06	250 031 06
Burner-mounted KS20 controller (W-FM 50)			250 033 15	250 033 15	250 033 15
W-FM 100 (suitable for continuous firing) in lieu of W-FM 50 ²⁾			burner-mounted	210 030 38	210 030 38
			supplied loose	210 030 87	210 030 87
DSB 158 oil pressure switch in supply ²⁾			210 030 46	210 030 46	210 030 46
Integral load controller and analogue signal convertor for W-FM 100			110 017 18	110 017 18	110 017 18
W-FM 200 in lieu of W-FM 50 with integral load controller, analogue signal convertor, and VSD module, with optional fuel metering			burner-mounted	210 030 39	210 030 39
			supplied loose	Please enquire	Please enquire
VSD with integral frequency convertor (W-FM 50 / 200 required)			210 030 40	210 030 40	210 030 40
VSD with separate frequency convertor (W-FM 200 required) (See accessories list for frequency convertor)			Please enquire	Please enquire	Please enquire
WM-D112 motor with 230 V contactor and overload protection ¹⁾			250 030 95	250 030 95	250 030 95
ABE with Chinese-character display, supplied loose (W-FM 100 / 200)			110 018 53	110 018 53	110 018 53
Special voltage (on application only)			210 030 69	210 030 69	210 030 69
110 V control voltage			250 031 72	250 031 72	250 031 72

Country-specific executions and special voltages on application

¹⁾ The necessary motor protection can be provided either by a motor protection switch (supplied and fitted into a panel by others), or with integral motor overload protection (see special equipment).

²⁾ Required for PED (2014/68/EU) compliance.

Special equipment WM-G20, versions ZM and ZM-LN

Versions ZM and ZM-LN		WM-G20/2-A ZM	WM-G20/3-A ZM	WM-G20/2-A LN	WM-G20/3-A LN
Combustion head extension	by 100 mm	250 030 79	250 030 79	250 030 87	250 030 87
	by 200 mm	250 030 80	250 030 80	250 030 88	250 030 88
	by 300 mm	250 030 81	250 030 81	250 030 89	250 030 89
Solenoid valve for air pressure switch test with continuous-run fan or post-purge		250 030 21	250 030 21	250 030 21	250 030 21
High gas pressure switch ²⁾ (Screwed W-MF / DMV for low-pressure supplies)	GW 50 A6/1	250 033 30	250 033 30	250 033 30	250 033 30
	GW 150 A6/1	250 033 31	250 033 31	250 033 31	250 033 31
	GW 500 A6/1	250 033 32	250 033 32	250 033 32	250 033 32
High gas pressure switch ²⁾ (Flanged DMV / VGD for low-pressure supplies)	GW 50 A6/1	150 017 49	150 017 49	150 017 49	150 017 49
	GW 150 A6/1	150 017 50	150 017 50	150 017 50	150 017 50
	GW 500 A6/1	150 017 51	150 017 51	150 017 51	150 017 51
High gas pressure switch ²⁾ (Fitted to high-pressure regulator)	GW 50 A6/1	250 033 33	250 033 33	250 033 33	250 033 33
	GW 150 A6/1	250 033 34	250 033 34	250 033 34	250 033 34
	GW 500 A6/1	250 033 35	250 033 35	250 033 35	250 033 35
ST 18/7 and ST 18/4 plug connections (W-FM 50 / 100 / 200)		250 030 22	250 030 22	250 030 22	250 030 22
ST 18/7 plug connection (W-FM 50 with KS20)		250 031 06	250 031 06	250 031 06	250 031 06
Air inlet flange for ducted-air connection, with LGW air pressure switch		210 030 47	210 030 47	210 030 47	210 030 47
Burner-mounted KS20 controller (W-FM 50)		250 033 15	250 033 15	250 033 15	250 033 15
W-FM 100 (suitable for continuous firing) in lieu of W-FM 50 ²⁾	burner-mounted	250 030 74	250 030 74	250 030 74	250 030 74
	supplied loose	250 031 43	250 031 43	250 031 43	250 031 43
Integral load controller & analogue signal convertor for W-FM 100		110 017 18	110 017 18	110 017 18	110 017 18
W-FM 200 in lieu of W-FM 50 with integral load controller, analogue signal convertor, and VSD module, with optional fuel metering	burner-mounted	250 030 75	250 030 75	250 030 75	250 030 75
	supplied loose	250 030 48	250 030 48	250 030 48	250 030 48
VSD with integral frequency convertor (W-FM 50 / 200 required)		210 030 40	210 030 40	210 030 40	210 030 40
VSD with separate frequency convertor (W-FM 200 required) (See accessories list for frequency convertor)		210 030 41	210 030 41	210 030 41	210 030 41
W-FM 200 with extended O ₂ trim / CO control functionality		250 033 78	250 033 78	250 033 78	250 033 78
WM-D112 motor with 230 V contactor and overload protection ¹⁾		250 030 95	250 030 95	250 030 95	250 030 95
ABE with Chinese-character display, supplied loose (W-FM 100 / 200)		110 018 53	110 018 53	110 018 53	110 018 53
Special voltage (on application only)		250 031 02	250 031 02	250 031 02	250 031 02
110 V control voltage		250 031 72	250 031 72	250 031 72	250 031 72
Offset gas butterfly valve and gas valve assembly for vertical firing		250 032 95	250 032 95	250 032 95	250 032 95
Flue gas recirculation (must be sized by factory)		250 034 72	250 034 72	250 034 72	250 034 72

Country-specific executions and special voltages on application

¹⁾ The necessary motor protection can be provided either by a motor protection switch (supplied and fitted into a panel by others), or with integral motor overload protection (see special equipment).

²⁾ Required for PED (2014/68/EU) compliance.

Special equipment WM-GL20, version ZM-T

Version ZM-T		WM-GL20/2-A	WM-GL20/3-A	
Combustion head extension	by 100 mm	250 031 17	250 031 20	
	by 200 mm	250 031 18	250 031 21	
	by 300 mm	250 031 19	250 031 22	
Solenoid valve for air pressure switch test with continuous-run fan or post-purge		250 030 21	250 030 21	
High gas pressure switch ³⁾ (Screwed W-MF / DMV for low-pressure supplies)	GW 50 A6/1	250 033 30	250 033 30	
	GW 150 A6/1	250 033 31	250 033 31	
	GW 500 A6/1	250 033 32	250 033 32	
High gas pressure switch ³⁾ (Flanged DMV / VGD for low-pressure supplies)	GW 50 A6/1	150 017 49	150 017 49	
	GW 150 A6/1	150 017 50	150 017 50	
	GW 500 A6/1	150 017 51	150 017 51	
High gas pressure switch ³⁾ (Fitted to high-pressure regulator)	GW 50 A6/1	250 033 33	250 033 33	
	GW 150 A6/1	250 033 34	250 033 34	
	GW 500 A6/1	250 033 35	250 033 35	
ST 18/7 and ST 18/4 plug connections (W-FM 54)		250 031 99	250 031 99	
ST 18/7 plug connection (W-FM 100 / 200)		250 032 01	250 032 01	
Electromagnetic clutch		250 031 16	250 031 16	
Air inlet flange for ducted-air connection, with LGW air pressure switch		210 030 47	210 030 47	
Oil meter	< 150 kg	VZ08 without transmitter	250 031 33	250 031 33
		VZ08 with low-frequency transmitter for external wiring	250 031 31	250 031 31
		VZ020 without transmitter	250 031 34	250 031 34
	> 150 kg	VZ020 with low-frequency transmitter for external wiring	250 031 35	250 031 35
		VZ020 with low-frequency transmitter for external wiring (W-FM 50 / 54 / 200)	210 031 24	210 031 24
		DSB 158 oil pressure switch in supply ³⁾	210 030 46	210 030 46
W-FM 100 (suitable for continuous firing) in lieu of W-FM 54, with integral load controller and analogue signal convertor ²⁾	burner-mounted	250 031 78	250 031 78	
	supplied loose	250 031 93	250 031 93	
W-FM 200 in lieu of W-FM 54 with integral load controller, analogue signal convertor and VSD module, with optional fuel metering	burner-mounted	250 031 77	250 031 77	
	supplied loose	250 031 62	250 031 62	
Oil hoses, 1300 mm in lieu of 1000 mm		110 000 72	110 000 72	
WM-D112 motor with 230 V contactor and overload protection ¹⁾		250 030 95	250 030 95	
VSD with integral frequency convertor (W-FM 54 / 200 required) ²⁾		210 030 40	210 030 40	
VSD with separate frequency convertor (W-FM 200 required) ²⁾ (See accessories list for frequency convertor)		Please enquire	Please enquire	
ABE with Chinese-character display, supplied loose (W-FM 100 / 200)		110 018 53	110 018 53	
Special voltage (on application only)		210 030 69	210 030 69	
110 V control voltage (W-FM 50 / 100 / 200) (W-FM 54)		250 031 72	250 031 72	
		Please enquire	Please enquire	
Offset gas butterfly valve and gas valve assembly for vertical firing		250 032 95	250 032 95	

Country-specific executions and special voltages on application

¹⁾ The necessary motor protection can be provided either by a motor protection switch (supplied and fitted into a panel by others), or with integral motor overload protection (see special equipment).

²⁾ VSD with ZM-T version burners: When firing on oil (i.e. without modulating capacity regulation), operation at 100 % speed is recommended.

³⁾ Required for PED (2014/68/EU) compliance.

Special equipment WM-GL20, version ZM-R

Version ZM-R		WM-GL20/2-A	WM-GL20/3-A
Combustion head extension	by 100 mm	250 031 23	250 031 26
	by 200 mm	250 031 24	250 031 27
	by 300 mm	250 031 25	250 031 28
Solenoid valve for air pressure switch test with continuous-run fan or post-purge		250 030 21	250 030 21
High gas pressure switch ³⁾ (Screwed W-MF / DMV for low-pressure supplies)	GW 50 A6/1	250 033 30	250 033 30
	GW 150 A6/1	250 033 31	250 033 31
	GW 500 A6/1	250 033 32	250 033 32
High gas pressure switch ³⁾ (Flanged DMV / VGD for low-pressure supplies)	GW 50 A6/1	150 017 49	150 017 49
	GW 150 A6/1	150 017 50	150 017 50
	GW 500 A6/1	150 017 51	150 017 51
High gas pressure switch ³⁾ (Fitted to high-pressure regulator)	GW 50 A6/1	250 033 33	250 033 33
	GW 150 A6/1	250 033 34	250 033 34
	GW 500 A6/1	250 033 35	250 033 35
ST 18/7 and ST 18/4 plug connections (W-FM 54 / 100 / 200)		250 030 22	250 030 22
Electromagnetic clutch		Standard	Standard
Air inlet flange for ducted-air connection, with LGW air pressure switch		210 030 47	210 030 47
DSB 158 oil pressure switch in supply ³⁾		210 030 46	210 030 46
W-FM 100 (suitable for continuous firing) ³⁾ in lieu of W-FM 54	burner-mounted	250 031 76	250 031 76
	supplied loose	250 031 82	250 031 82
Integral load controller and analogue signal convertor for W-FM 100		110 017 18	110 017 18
W-FM 200 in lieu of W-FM 54 with integral load controller, analogue signal convertor and VSD module with optional fuel metering	burner-mounted	250 031 77	250 031 77
	supplied loose	250 031 63	250 031 63
Oil hoses, 1300 mm in lieu of 1000 mm		110 001 59	110 001 59
WM-D112 motor with 230 V contactor and overload protection ¹⁾		250 030 95	250 030 95
VSD with integral frequency convertor (W-FM 54 / 200 required) ²⁾		210 030 40	210 030 40
VSD with separate frequency convertor (W-FM 200 required) ²⁾ (See accessories list for frequency convertor)		210 030 41	210 030 41
ABE with Chinese-character display, supplied loose (W-FM 100 / 200)		110 018 53	110 018 53
Special voltage (on application only)		210 030 69	210 030 69
110 V control voltage (W-FM 50 / 100 / 200) (W-FM 54)		250 031 72	250 031 72
		Please enquire	Please enquire
Offset gas butterfly valve and gas valve assembly for vertical firing		250 032 95	250 032 95

Country-specific executions and special voltages on application

¹⁾ The necessary motor protection can be provided either by a motor protection switch (supplied and fitted into a panel by others), or with integral motor overload protection (see special equipment).

²⁾ VSD with ZM-R version burners: General conditions for modulating capacity regulation when firing on oil
– Frequency: min. 35 Hz
– Turndown: max. 3:1

³⁾ Required for PED (2014/68/EU) compliance.

Technical data Oil burners

Oil burners		WM-L20/1-A T	WM-L20/2-A T	WM-L20/3-A T
Burner motor	Weishaupt type	WM-D 112/140-2/3K0	WM-D 112/140-2/3K5	WM-D 112/170-2/4K5
Motor power output	kW	3.0	3.5	4.5
Nominal current	A	6.5	7.2	9.2
Motor protection switch ¹⁾ or motor prefusing ¹⁾ (with overload protection)	type (e.g.) A minimum	PKE12/XTU-12	PKE12/XTU-12	PKE12/XTU-12
Speed (50 Hz)	rpm	2950	2940	2930
Combustion manager	type	W-FM 50	W-FM 50	W-FM 50
Flame monitoring	type	ORB	ORB	ORB
Air damper / oil actuator	type	STE 50	STE 50	STE 50
Integral pump max. flow rate	type l/h	J6 290	J6 290	J7 392
NO _x Class per EN 267		2	2	2
Oil hoses	DN / length	13 / 1000	13 / 1000	13 / 1000
Mass	kg	approx. 88	approx. 88	approx. 96

Oil burners		WM-L20/1-A R	WM-L20/2-A R	WM-L20/3-A R
Burner motor	Weishaupt type	WM-D 112/140-2/3K0	WM-D 112/140-2/3K5	WM-D 112/170-2/4K5
Motor power output	kW	3.0	3.5	4.5
Nominal current	A	6.5	7.2	9.2
Motor protection switch ¹⁾ or motor prefusing ¹⁾ (with overload protection)	type (e.g.) A minimum	PKE12/XTU-12	PKE12/XTU-12	PKE12/XTU-12
Speed (50 Hz)	rpm	2950	2940	2930
Combustion manager	type	W-FM 50	W-FM 50	W-FM 50
Flame monitoring	type	ORB	ORB	ORB
Air damper / oil actuator	type	STE 50	STE 50	STE 50
Integral pump max. flow rate	type l/h	TA2 525	TA2 525	TA3 785
NO _x Class per EN 267		2	2	2
Oil hoses	DN / length	20 / 1000	20 / 1000	20 / 1000
Mass	kg	approx. 96	approx. 96	approx. 104

¹⁾ The necessary motor protection can be provided either by a motor protection switch (supplied and fitted into a panel by others), or with integral motor overload protection (see special equipment).

Voltages and frequencies:

The burners are equipped as standard for three-phase alternating current, 400 V, 3 ~, 50 Hz. Other voltages and frequencies are available on application.

Standard burner motor:

Insulation Class F, IP 55 protection.
IE3 Premium Efficiency.

Technical data

Gas and dual-fuel burners

Gas burners		WM-G20/2-A	WM-G20/3-A
Burner motor	Weishaupt type	WM-D 112/140-2/3K0	WM-D 112/140-2/3K5
Motor power output	kW	3.0	3.5
Nominal current	A	6.5	7.2
Motor protection switch ¹⁾ or motor prefusing ¹⁾ (with overload protection)	type (e.g.)	PKE12/XTU-12	PKE12/XTU-12
Speed (50 Hz)	rpm	2950	2940
Combustion manager	type	W-FM 50	W-FM 50
Flame monitoring	type	ION	ION
Air damper / gas actuator	type	STE 50	STE 50
NO _x Class per EN 676	ZM / ZM-LN	2 / 3	2 / 3
Mass (excl. double gas valve assembly and fittings)	kg	approx. 97	approx. 97

Dual-fuel burners, version ZM-T		WM-GL20/2-A	WM-GL20/3-A
Burner motor	Weishaupt type	WM-D 112/140-2/3K5	WM-D 112/170-2/4K5
Motor power output	kW	3.5	4.5
Nominal current	A	7.2	9.2
Motor protection switch ¹⁾ or motor prefusing ¹⁾ (with overload protection)	type (e.g.)	PE12/XTU-12	PE12/XTU-12
Speed (50 Hz)	rpm	2940	2930
Combustion manager	type	W-FM 54	W-FM 54
Flame monitoring	type	QRA2	QRA2
Air damper / gas actuator	type	STE 50	STE 50
NO _x Class per EN 676 / EN 267		2 / 2	2 / 2
Mass (excl. double gas valve assembly and fittings)	kg	approx. 107	approx. 110
Integral pump max. flow rate	type / l/h	J6 / 290	J7 / 392
Oil hoses	DN / length	13 / 1000	13 / 1000

Dual-fuel burners, version ZM-R		WM-GL20/2-A	WM-GL20/3-A
Burner motor	Weishaupt type	WM-D 112/140-2/3K5	WM-D 112/170-2/4K5
Motor power output	kW	3.5	4.5
Nominal current	A	7.2	9.2
Motor protection switch ¹⁾ or motor prefusing ¹⁾ (with overload protection)	type (e.g.)	PKE12/XTU-12	PKE12/XTU-12
Speed (50 Hz)	rpm	2940	2930
Combustion manager	type	W-FM 54	W-FM 54
Flame monitoring	type	QRA2	QRA2
Air damper / gas / oil actuator	type	STE 50	STE 50
NO _x Class per EN 676 / EN 267		2 / 2	2 / 2
Mass (excl. double gas valve assembly and fittings)	kg	approx. 120	approx. 128
Integral pump max. flow rate	type / l/h	TA2 / 525	TA3 / 785
Oil hoses	DN / length	20 / 1000	20 / 1000

¹⁾ The necessary motor protection can be provided either by a motor protection switch (supplied and fitted into a panel by others), or with integral motor overload protection (see special equipment).

Voltages and frequencies:
The burners are equipped as standard for three-phase alternating current, 400 V, 3 ~, 50 Hz. Other voltages and frequencies are available on application.

Standard burner motor:
Insulation Class F, IP 55 protection. IE3 Premium Efficiency.

Fuel systems

Gas-side fuel system

W-FM 50 / 100 / 200

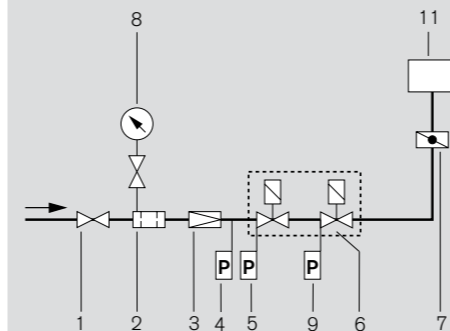

- 1 Ball valve *
- 2 Gas filter *
- 3 Pressure regulator, (LP) or (HP) *
- 4 High gas pressure switch *
- 5 Low gas pressure switch
- 6 Double gas valve assembly
- 7 Gas butterfly valve
- 8 Pressure gauge with push-button valve *
- 9 Valve-proving pressure switch
- 10 Low gas / valve-proving pressure switch
- 11 Burner

Layout of the valve train

On boilers with hinged doors, the valve train must be mounted on the opposite side to the boiler-door hinges.

Compensator

To enable a tension free mounting of the valve train, the fitting of a compensator is strongly recommended.

Break points in the valve train

Break points in the valve train should be provided to enable the door of the heat generator to be swung open. The main gas line is best separated at the compensator.

W-FM 54

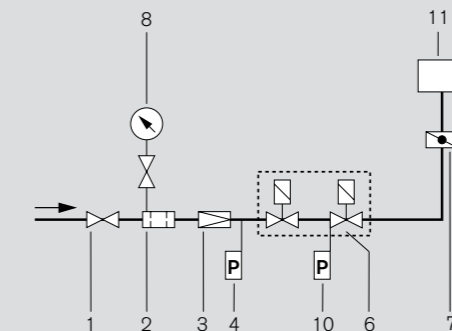

* Not included in burner price

Mounting position of the high gas pressure switch:
On the regulator outlet of HP trains
After the regulator of screwed LP trains
On the valve assembly inlet of flanged LP trains
Cable length approx. 2.5 m.

Support of the valve train

The valve train should be properly supported in accordance with the site conditions. See the Weishaupt accessories list for various valve train support components.

Gas meter

A gas meter must be installed to measure gas consumption during commissioning and servicing.

Optional thermal shutoff (when required by local regulations)

Integrated into the ball valve of screwed valve trains. A separate component with HTB seals fitted before the ball valve on flanged valve trains.

Oil-side fuel system

Version (ZM-T)

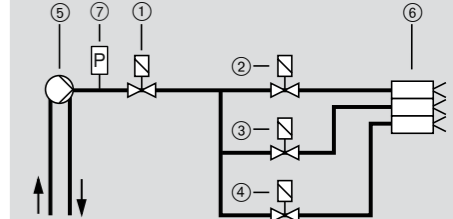

- ① Safety solenoid valve
- ② Stage 1 solenoid valve
- ③ Stage 2 solenoid valve
- ④ Stage 3 solenoid valve
- ⑤ Burner-mounted oil pump
- ⑥ Nozzle head with 3 oil atomising nozzles
- ⑦ Pressure switch in supply (optional)

Version (ZM-R)

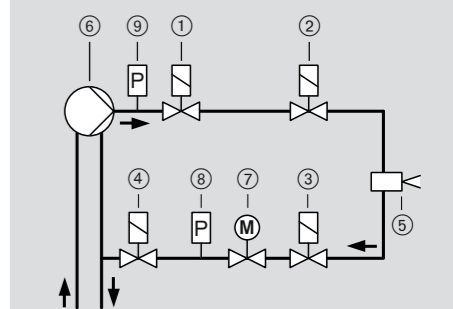

- ① Normally closed solenoid valve 1st shut-off device in supply
- ② Normally closed solenoid valve 2nd shut-off device in supply
- ③ Normally closed solenoid valve 1st shut-off device in return
- ④ Normally closed solenoid valve 2nd shut-off device in return
- ⑤ Nozzle head with regulating nozzle
- ⑥ Burner-mounted oil pump
- ⑦ Oil regulator
- ⑧ Pressure switch in return
- ⑨ Pressure switch in supply (optional)

Dimensions

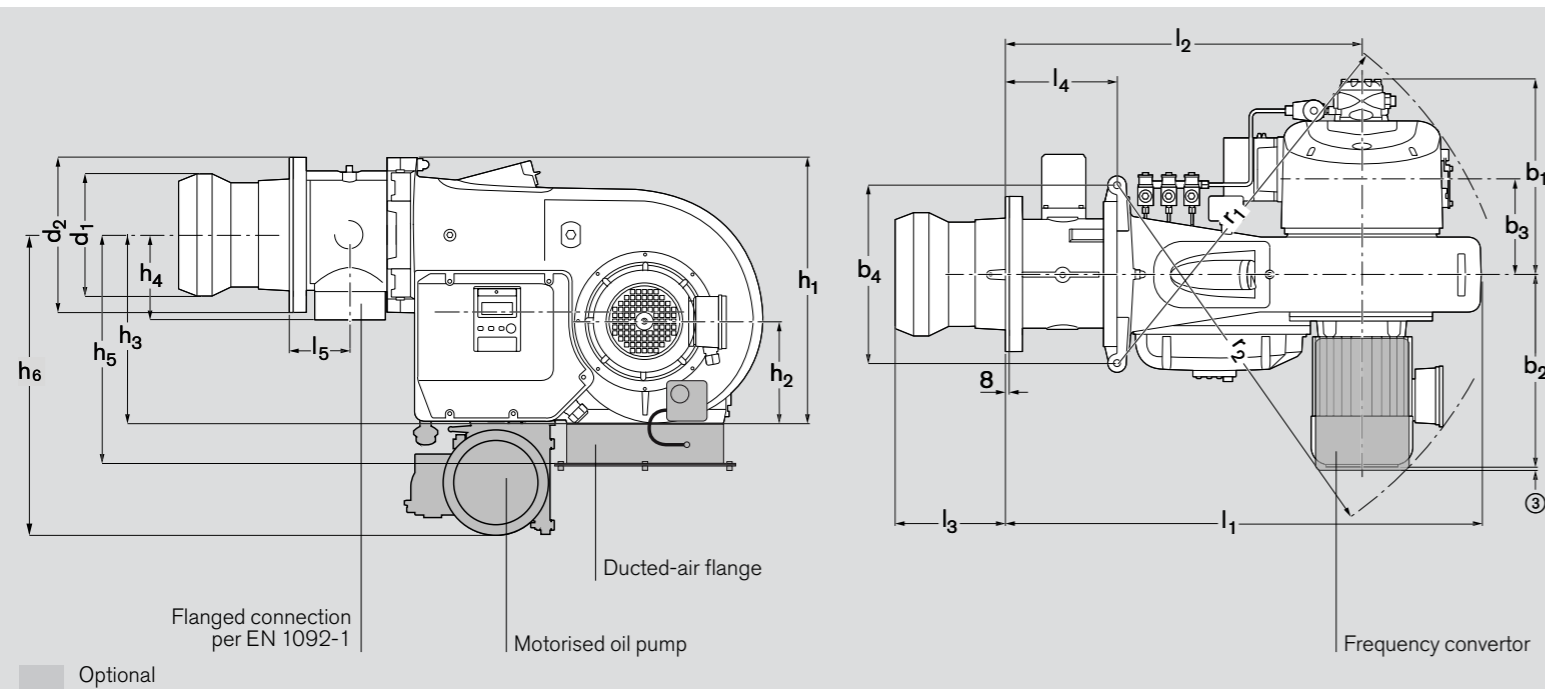

Underside of ducted-air flange

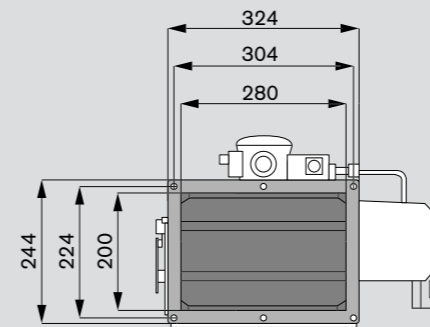

Mounting-plate drilling dimensions

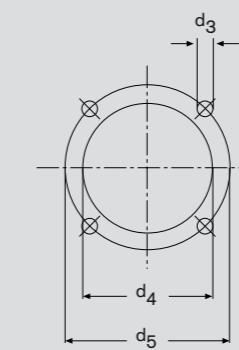

Heat generator preparation

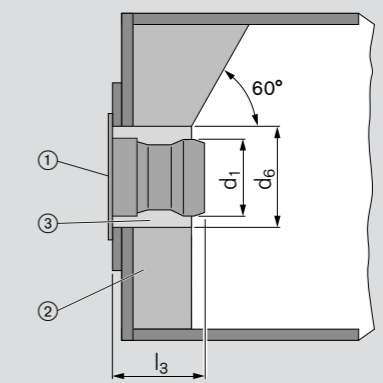

- ① Flange gasket
- ② Refractory
- ③ Aperture

The refractory ② must not protrude beyond the front edge of the combustion head. It may however be tapered (min. 60°).

Burner type	Dimensions in mm															
	l ₁	l ₂	l ₃	l ₄	l ₅	b ₁ ^①	b ₂	b ₃	b ₄	h ₁	h ₂	h ₃	h ₄	h ₅	h ₆	
WM-L20/1-A T	810	557	217-232	38	-	411	424	209	380	573	225	408	-	470	567	
WM-L20/2-A T	810	557	227-247	38	-	411	424	209	380	573	225	408	-	470	567	
WM-L20/3-A T	810	557	237-257	38	-	411	447	209	380	573	225	408	-	470	574	
WM-L20/1-A R	810	557	217-232	38	-	409	424	209	380	573	225	408	-	470	574	
WM-L20/2-A R	810	557	227-247	38	-	409	424	209	380	573	225	408	-	470	574	
WM-L20/3-A R	810	557	237-257	38	-	414	447	209	380	573	225	408	-	470	604	
WM-G20/2-A ZM	1010	757	231-266	238	128	326	424	209	380	573	225	408	182	470	-	
WM-G20/3-A ZM	1010	757	231-256	238	128	326	424	209	380	573	225	408	182	470	-	
WM-G20/2-A ZM-LN	1010	757	247-267	238	128	326	424	209	380	573	225	408	182	470	-	
WM-G20/3-A ZM-LN	1010	757	247-272	238	128	326	424	209	380	573	225	408	182	470	-	
WM-GL20/2-A ZM-T	1010	757	231-266	238	128	411	424	209	380	573	225	408	182	470	567	
WM-GL20/3-A ZM-T	1010	757	231-256	238	128	411	447	209	380	573	225	408	182	470	574	
WM-GL20/2-A ZM-R	1010	757	231-266	238	128	545 ^②	424	209	380	573	225	408	182	470	574	
WM-GL20/3-A ZM-R	1010	757	231-256	238	128	545 ^②	447	209	380	573	225	408	182	470	604	

① Excluding electromagnetic clutch (additional 130 mm projection for pump with electromagnetic clutch on versions T and R)
 ② Including electromagnetic clutch
 ③ Additional projection with frequency convertor approx. 20 mm

Burner type	Dimensions in mm								Nom. diameter of gas butterfly
	r ₁	r ₂	d ₁	d ₂	d ₃	d ₄	d ₅	d ₆	
WM-L20/1-A / T	840	869	200	330	M12	240	298	240	-
WM-L20/2-A / T	840	869	220	330	M12	260	298	260	-
WM-L20/3-A / T	840	883	240	330	M12	270	298	280	-
WM-L20/1-A / R	840	869	200	330	M12	240	298	240	-
WM-L20/2-A / R	840	869	220	330	M12	260	298	260	-
WM-L20/3-A / R	840	883	240	330	M12	270	298	280	-
WM-G20/2-A ZM	840	869	250	330	M12	270	298	290	DN65
WM-G20/3-A ZM	840	869	260	330	M12	270	298	290	DN65
WM-G20/2-A ZM-LN	840	869	250	330	M12	270	298	290	DN65
WM-G20/3-A ZM-LN	840	869	260	330	M12	270	298	290	DN65
WM-GL20/2-A ZM-T	840	869	250	330	M12	270	298	290	DN65
WM-GL20/3-A ZM-T	840	883	260	330	M12	270	298	290	DN65
WM-GL20/2-A ZM-R	925	869	250	330	M12	270	298	290	DN65
WM-GL20/3-A ZM-R	925	883	260	330	M12	270	298	290	DN65

All dimensions are approximate.
 Weishaupt reserve the right to make changes in light of future developments.

ZMI-version Weishaupt monarch[®] burners

More power in compact form

The ZMI version of the Weishaupt WM-G20 monarch[®] burner was developed especially with industrial applications in mind. This burner, with its large turndown range, is designed for use on process plant.

The burner can achieve a turndown of up to 15:1 and its output is matched – within its operating range – to current heat demand.

Fuels

Natural gas
LPG

The suitability of fuels of differing quality must be confirmed in advance with Weishaupt.

Notes on operation

ZMI-version burners are only suitable for use on process plant if the following fundamental conditions are met:

- The flame must not be impeded in the combustion chamber by process-specific flue gas circulation or by secondary air.
- A flue gas sampling point must be available prior to dilution by any other sources.
- A flame viewing port must be available.
- A gas flow meter / throughput indicator is essential for setting the burner.
- Additional requirements can be found on datasheet 8-1 in the Weishaupt technical folder.

Zero governor

The ZMI version of the Weishaupt WM-G20 gas burner is additionally equipped with a zero governor. The zero governor is connected to the burner's airflow upstream of the fan by a flexible impulse line.

A higher pressure from the burner's fan results in a higher gas pressure at the outlet of the zero governor. A lower fan pressure results in a lower gas pressure at the outlet of the zero governor.



Standards compliance

The ZMI version of the Weishaupt WM-G20 burner is not type approved. The burner's safety equipment meets the requirements of EN 676.

If an approval inspection is required, this should be arranged with the appropriate body by the plant operator.

The burners are labelled with a CE mark

and fulfil the requirements of the following EU directives:

- MD** Machinery Directive 2006/42/EC
- EMC** EMC Directive 2014/30/EU
- LVD** Low Voltage Directive 2014/35/EU
- PED** Pressure Equipment Directive 2014/68/EU

Burner selection, valve train sizing, order numbers

WM-G20, version ZMI

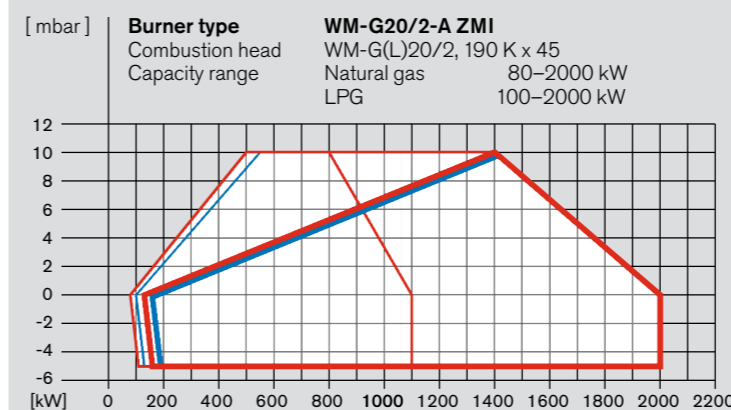

WM-G20/2-A, version ZMI

Burner rating kW	Press. at gas b/fly at full load mbar	Low-pressure supply (with FRS) (flow pressure in mbar into shut-off valve, $P_1 \leq 300$ mbar)						High-pressure supply (with HP regulator) (flow pressure in mbar into gas valve assembly)					
		Nominal valve train diameter			Nominal diameter of gas butterfly			Nominal valve train diameter			Nominal diameter of gas butterfly		
		1" 1½"	2"	65	80	100	125	1" 1½"	2"	65	80	100	125
		65	65	65	65	65	65	65	65	65	65	65	65

Erdgas E (N)	$H_i = 10,35 \text{ kWh/m}^3; d = 0,606; W_i = 13,295 \text{ kWh/m}^3$												
	500	4	32	15	9	-	-	22	12	6	-	-	-
700	5	58	25	13	10	9	8	40	20	10	7	6	6
900	7	91	37	18	13	11	10	64	31	14	9	8	7
1100	8	134	52	23	16	13	12	94	45	19	12	10	9
1300	9	-	69	29	19	15	13	128	60	23	14	11	10
1500	9	-	89	35	22	17	14	13	-	77	29	16	13
1700	10	-	111	43	25	18	15	14	-	97	35	19	14
2000	11	-	150	55	31	22	16	15	-	131	45	23	16

Erdgas LL (N)	$H_i = 8,83 \text{ kWh/m}^3; d = 0,641; W_i = 11,029 \text{ kWh/m}^3$												
	500	4	43	19	10	-	-	30	15	7	-	-	-
700	6	80	33	16	11	10	9	56	27	12	8	7	6
900	7	130	50	22	15	12	11	91	43	18	11	9	8
1100	9	190	72	30	20	15	13	134	62	25	15	12	10
1300	10	-	97	38	24	18	15	14	-	84	32	18	14
1500	11	-	126	48	28	21	16	15	-	110	40	21	16
1700	12	-	-	59	33	23	18	16	-	139	49	25	18
2000	14	-	-	77	42	28	21	19	-	-	64	31	22

Flüssiggas* (F)	$H_i = 25,89 \text{ kWh/m}^3; d = 1,555; W_i = 20,762 \text{ kWh/m}^3$												
	500	4	17	10	-	-	-	11	7	5	-	-	-
700	5	28	14	10	8	-	-	19	11	7	6	5	5
900	6	42	20	12	10	9	8	29	16	9	7	6	6
1100	7	59	26	14	11	10	9	42	22	11	8	7	7
1300	7	80	33	17	12	11	10	56	28	13	9	8	7
1500	7	103	41	19	14	11	10	72	35	15	10	8	7
1700	7	130	50	22	15	12	11	91	43	18	11	9	8
2000	7	177	66	27	17	13	11	123	57	22	13	10	8

* The LPG charts are based on propane, but may also be used for butane.

Order numbers

Burner Type	Version	Valve train size	Order No.
WM-G20/2-A	ZMI	R 1	217 217 11
		R 1½	217 217 12
		R 2	217 217 13
		DN 65	217 217 14
		DN 80	217 217 15
		DN 100	217 217 16
		DN 125	217 217 17

See page 16 for scope of delivery

Nat. gas: Capacity with comb. head
Closed —
Open —

LPG: Capacity with comb. head
Closed —
Open —

Screwed	Flanged
R 1 W-MF 512	DN 65 DMV 5065/12
R 1½ W-M F512	DN 80 DMV 5080/12
R 2 DMV 525/12	DN 100 DMV 5100/12
	DN 125 VGD 40.125

Capacity graphs for gas and dual-fuel burners certified in accordance with EN 676 and EN 267.

Stated ratings are based on an air temperature of 20 °C and an installation at sea level. For installations at higher altitudes, a reduction in capacity of 1 % per 100 m above sea level should be taken into account.

Stated flow pressures are based on a combustion chamber resistance of 0 mbar. The combustion chamber pressure of the heat generator must be added to the figure determined from the above chart when sizing the gas valve train. Minimum flow pressure 15 mbar.

For low-pressure supplies, EN 88-compliant governors with safety diaphragms are used.

For high-pressure supplies, an EN 334-compliant high-pressure regulator should be selected from the following technical booklets:

- Regulators up to 4 bar, Print No. 83001202
- Regulators with safety devices, Print No. 83197902

Refer to the burner's rating plate for the maximum connection pressure.

Special equipment Technical data

Special equipment		WM-G20/2-A ZMI
Combustion head extension	by 100 mm	250 033 10
	by 200 mm	250 033 11
	by 300 mm	250 033 12
Solenoid valve for air pressure switch test with continuous-run fan or post purge		250 030 21
High gas pressure switch fitted to flanged elbow	GW 50 A6/1	250 007 59
Air inlet flange for ducted-air connection, with LGW air pressure switch		210 030 47
ST 18/7 and ST 18/4 plug connections		250 030 22
W-FM 100 (suitable for continuous firing) in lieu of W-FM 50	burner-mounted	250 034 39
	supplied loose	250 034 40
Integral load controller and analogue signal convertor for W-FM 100		110 017 18
W-FM 200 in lieu of W-FM 50 with integral load controller, analogue signal convertor, and VSD module, with optional fuel metering	burner-mounted	250 034 41
	supplied loose	250 034 42
VSD with integral frequency converter (W-FM 50 / 200 required)		210 030 40
WM-D112 motor with 230 V contactor and overload protection ¹⁾		250 030 95
ABE with Chinese-character display, supplied loose (W-FM 100 / 200)		110 018 53

Country-specific executions and special voltages on application

¹⁾ The necessary motor protection can be provided either by a motor protection switch (supplied and fitted into a panel by others), or with integral motor overload protection (see special equipment).

Technical data		WM-G20/2-A ZMI
Burner motor	Weishaupt type	WM-D112/140-2/3K0
Motor power output	kW	3.0
Nominal current	A	6.5
Motor protection switch ¹⁾ or motor prefusing ¹⁾ (with overload protection)	type (e.g.)	PKE12/XTU-12
	A minimum	25 A gG / T (by others)
Speed (50 Hz)	rpm	2950
Combustion manager	type	W-FM 50
Flame monitoring	type	ION
Air damper / gas actuator	type	STE 50
Mass (excl. double gas valve assembly, zero governor, and fittings)	kg	approx. 97

¹⁾ The necessary motor protection can be provided either by a motor protection switch (supplied and fitted into a panel by others), or with integral motor overload protection (see special equipment).

Voltages and frequencies:

The burners are equipped as standard for three-phase alternating current, 400 V, 3 ~, 50 Hz. Other voltages and frequencies are available on application.

Standard burner motor:

Insulation Class F, IP 55 protection.
IE3 Premium Efficiency.

Dimensions

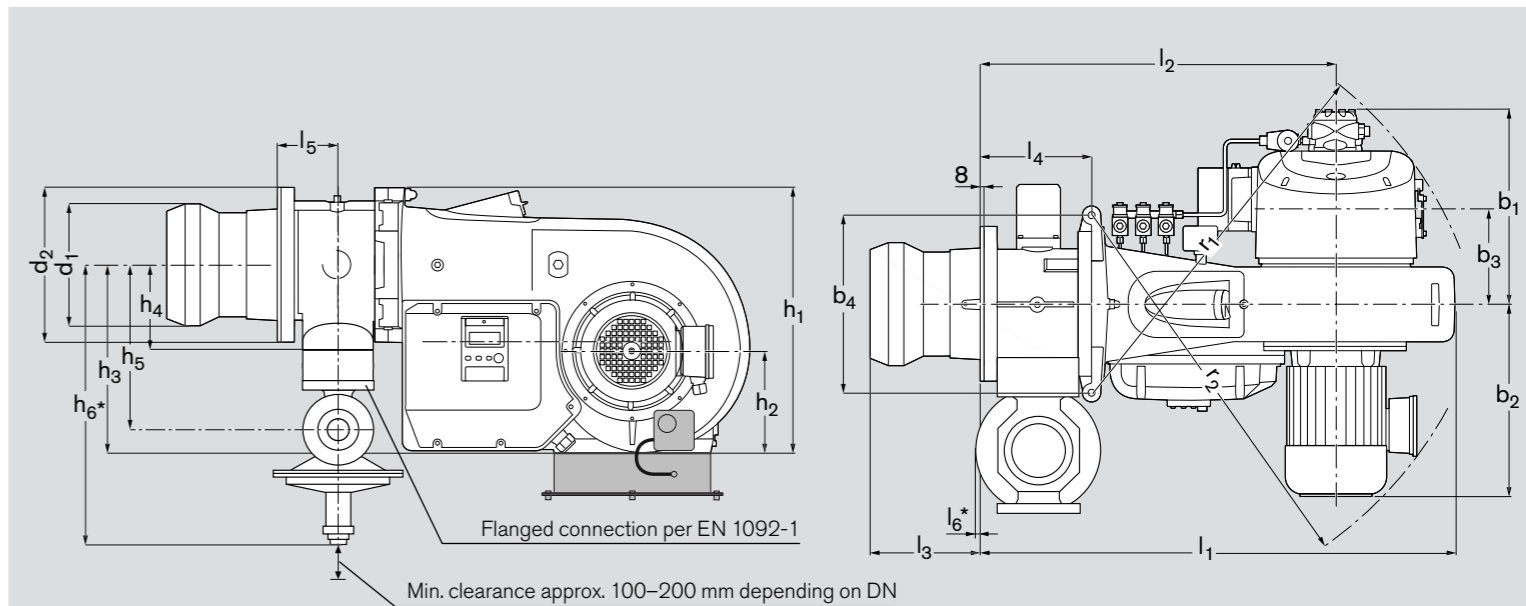

Optional

Size größe	Dimensions in mm												h ₁	h ₂	h ₃	h ₄	h ₅
	l ₁	l ₂	l ₃	l ₄	l ₅	Rp 1	Rp 1 ½	Rp 2	l ₆ * for DN								
20/2	1010	757	231-266	238	128	-	-	-	15	15	47	72	573	225	408	182	324

Size	Dimensions in mm																		
	h ₆ * bei DN				b ₁	b ₂	b ₃	b ₄	r ₁	r ₂	d ₁	d ₂	d ₃	d ₄	d ₅	d ₆			
Rp 1	Rp 1 ½	Rp 2	65	80													100	125	
20/2	481	534	587	637	629	709	834	326	424	209	380	840	869	250	330	M12	270	298	290

All dimensions are approximate. Weishaupt reserve the right to make changes in light of future developments.

* If the protrusion of the zero governor may foul the appliance mounting plate, then a spacer ring must be interposed between the plate and the burner flange (see accessories list). It should be noted that combustion head dimension l₃ is thereby reduced by the depth of the spacer ring.

Heat generator preparation

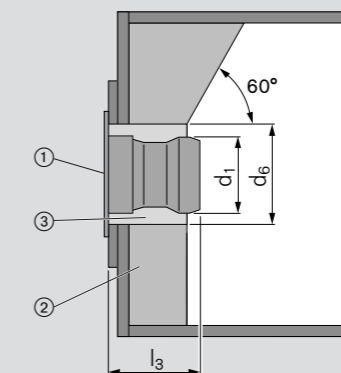

- ① Flange gasket
- ② Refractory
- ③ Aperture

The refractory ② must not protrude beyond the front edge of the combustion head. It may however be tapered (min. 60°).

Mounting-plate drilling dimensions

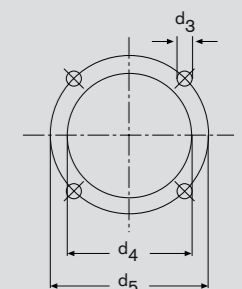

Saving fuel, reducing emissions: Patented multiflam® technology

Fuel system

Layout of the valve train

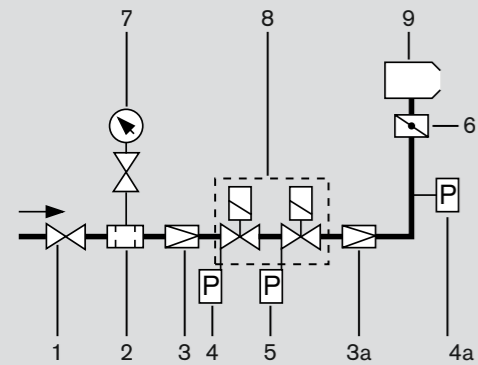

Legend:

- 1 Ball valve *
- 2 Gas filter *
- 3 Pressure regulator, (LP) or (HP) *
- 3a Zero governor with impulse line
- 4 Low gas pressure switch
- 4a High gas pressure switch *
- 5 Valve-proving pressure switch
- 6 Gas butterfly valve
- 7 Pressure gauge with push-button valve *
- 8 Double gas valve assembly
- 9 Burner

* Not included in burner price

Layout of the valve train

On boilers with hinged doors, the valve train must be mounted on the opposite side to the boiler-door hinges.

Compensator

To enable a tension free mounting of the valve train, the fitting of a compensator is strongly recommended.

Break points in the valve train

Break points in the valve train should be provided to enable the door of the heat generator to be swung open. The main gas line is best separated at the compensator.

Support of the valve train

The valve train should be properly supported in accordance with the site conditions. See the Weishaupt accessories list for various valve train support components.

Gas meter

A gas meter must be installed to measure gas consumption during commissioning and servicing.

Optional thermal shutoff (when required by local regulations)

Integrated into the ball valve of screwed valve trains. A separate component with HTB seals fitted before the ball valve on flanged valve trains.

Model designation

WM- G 20 / 2 - A ZMI

ZM = Sliding-two-stage operation
I = Turndown approx. 18:1
No CE PIN.

Mark

Capacity

Size

G = Gas

Weishaupt monarch® burner series

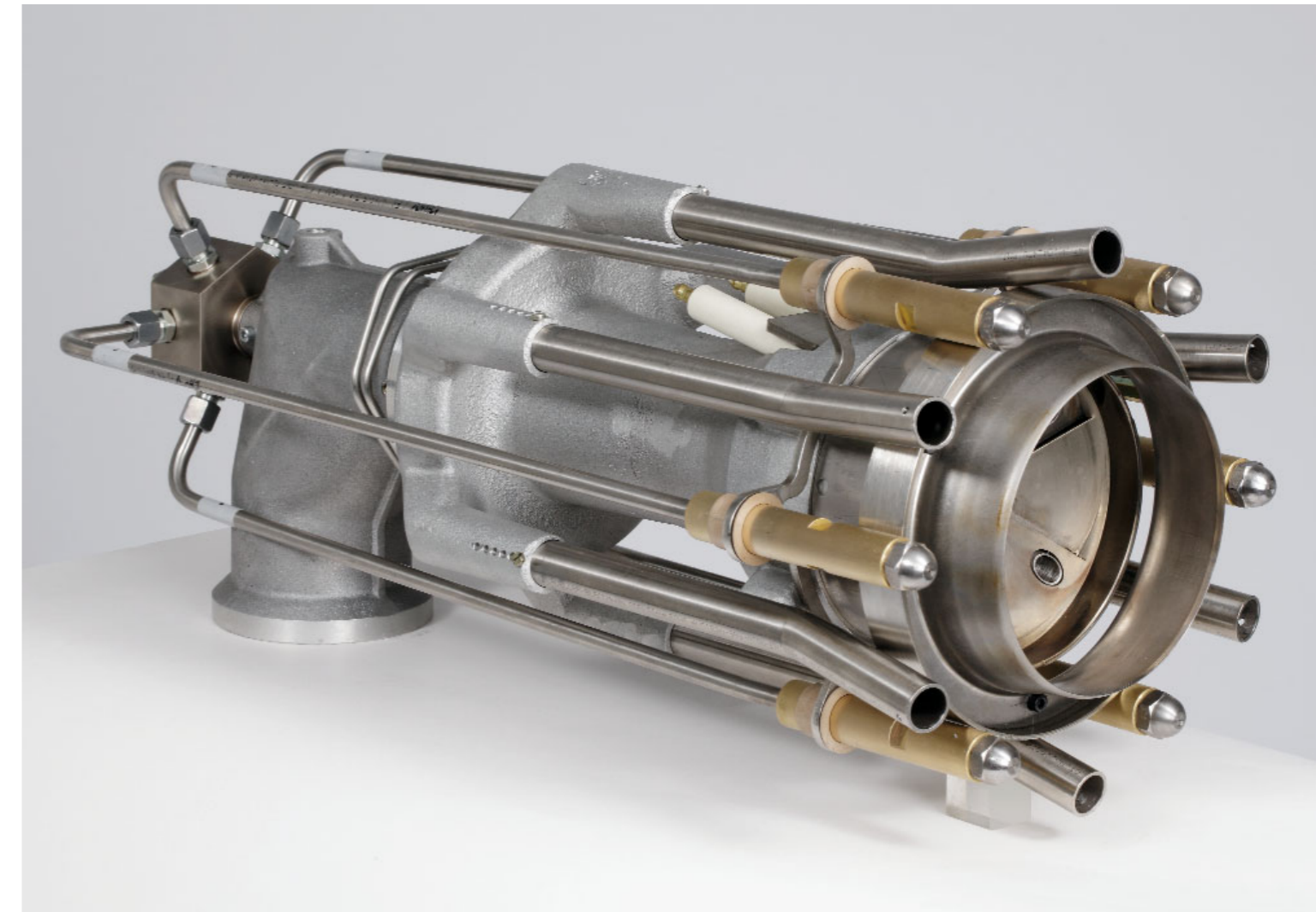

Weishaupt's patented multiflam® technology enables large combustion plant to meet very low emission limits without the need for expensive additional equipment. This reduction in emissions is achieved by using an innovative mixing assembly and fuel distribution system.

Weishaupt multiflam® burners have been proving themselves in the field for more than 10 years. They are especially suited to markets with stringent emission limits.

Monarch® burners bring this technology to medium-capacity ranges, combining flexibility with extremely low emissions.

Exemplary emissions

At the heart of Weishaupt's multiflam® technology lies a special mixing assembly design. Fuel is distributed among several nozzles and combusted in a primary and a secondary flame. Temperature in the flame's core is considerably reduced, resulting in an effective reduction of nitrogen oxides.

Good combustion figures also depend on combustion chamber geometry, volumetric loading and boiler design (three-pass type). Certain conditions (including, for example, combustion chamber loading, measurement tolerances, temperature, pressure, humidity etc.) must be observed in order for a guarantee of emission levels to be given.

Burner selection

WM-L20, version 3LN (multiflam®)

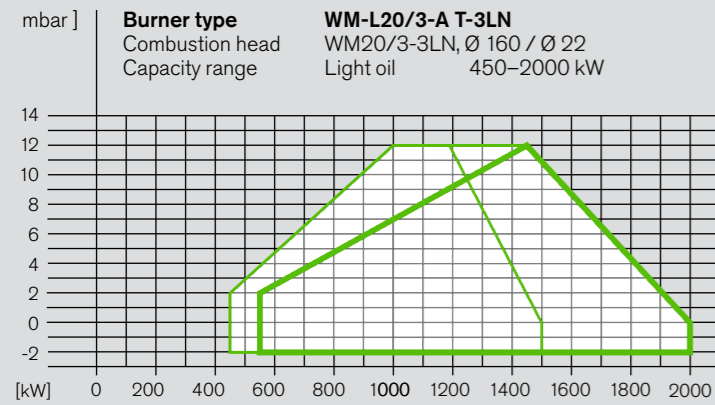
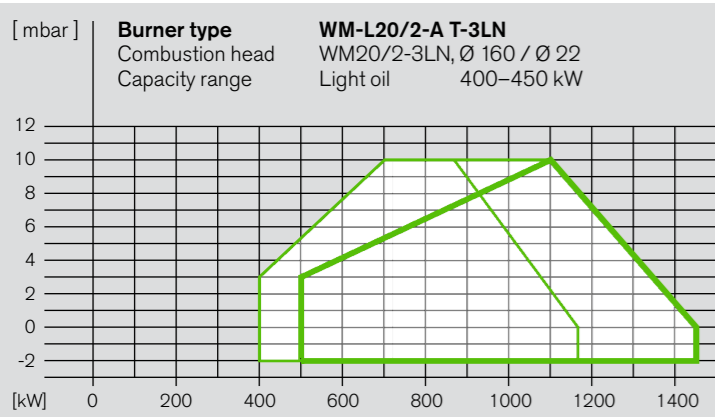

Light oil: Capacity with combustion head
 Closed
 Open

Capacity graphs for oil burners certified in accordance with EN 267.
 Stated ratings are based on an air temperature of 20 °C and an installation altitude of 500 m above sea level.

Stated oil throughputs are based on a nett calorific value (LHV) of 11.9 kWh/kg.

DIN CERTCO certification:
 The burners have been type-tested by an independent body (TÜV-Süd) and certified by DIN CERTCO.

Turndown:
 Light oil max. 3:1

Burner selection

WM-G20 and WM-GL20, vers. 3LN (multiflam®)

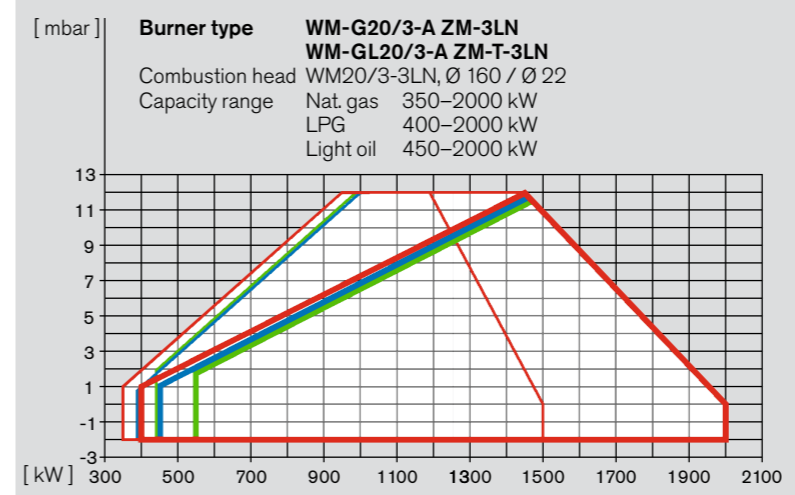
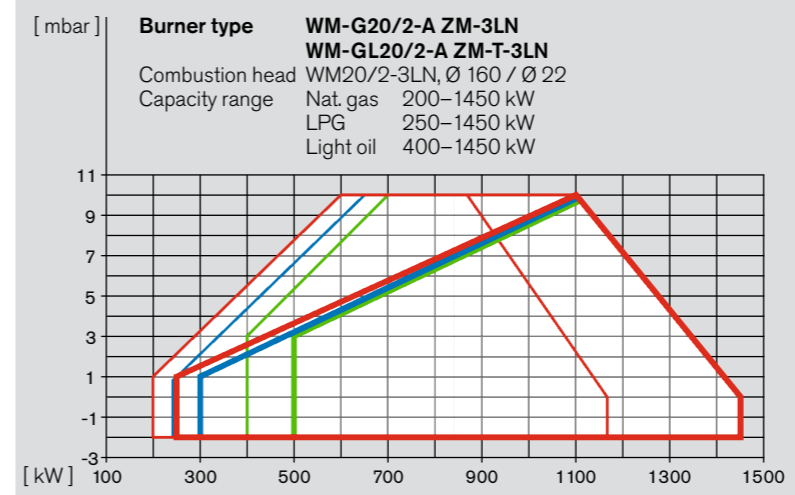

Nat. gas: Capacity with comb. head **LPG: Capacity with comb. head**
 Closed Closed
 Open Open

Light oil: Capacity with comb. head
 Closed
 Open

Turndown:
 Gas max. 5:1
 Light oil max. 3:1

Capacity graphs for gas and dual-fuel burners certified in accordance with EN 676 and EN 267.

Stated ratings are based on an air temperature of 20 °C and an installation at sea level. For installations at higher altitudes, a reduction in capacity of 1 % per 100 m above sea level should be taken into account.

Gas valve train sizing

WM-G20 and WM-GL20, vers. 3LN (multiflam®)

Scope of delivery

WM-G(L)20/2-A, version ZM(-T)-3LN (multiflam®)												
Burner rating kW	Low pressure supply (with FRS) (flow pressure in mbar into shut-off valve, $P_1 \leq 300$ mbar)						High pressure supply (with HP regulator) (flow pressure in mbar into gas valve assembly)					
	Nominal valve train diameter 1" 1½" 2" 65 80 100 125						Nominal valve train diameter 1" 1½" 2" 65 80 100 125					
	Nominal diameter of gas butterfly 65 65 65 65 65 65						Nominal diameter of gas butterfly 65 65 65 65 65 65					
Natural gas E LHV = 10.35 kWh/Nm³; d = 0.606												
600	45	21	13	10	10	9	16	12	8	7	7	6
700	62	29	17	14	13	13	22	18	12	11	10	10
800	81	38	22	19	17	16	30	24	16	14	14	13
900	101	47	28	23	21	20	38	31	20	18	17	17
1000	123	56	32	26	24	23	45	37	24	21	20	19
1100	146	65	36	28	26	24	52	42	26	23	22	21
1200	170	73	39	30	27	25	58	46	27	24	22	21
1300	195	82	42	31	27	25	65	50	29	24	23	22
1450	237	96	46	33	28	26	76	58	31	25	23	22
Natural gas LL LHV = 8.83 kWh/Nm³; d = 0.641												
600	63	27	15	12	11	10	20	16	9	8	7	7
700	86	38	21	17	15	14	29	23	14	12	11	11
800	112	49	27	22	20	18	39	31	19	17	16	15
900	141	62	34	27	24	23	50	39	24	21	20	19
1000	172	74	40	31	27	26	60	47	28	24	23	22
1100	204	86	44	33	29	27	69	53	31	26	25	24
1200	238	98	48	35	30	28	78	60	33	27	25	24
1300	275	110	52	37	31	28	87	66	34	28	26	24
1450	-	132	59	40	33	29	103	77	38	29	27	25
LPG* LHV = 25.89 kWh/Nm³; d = 1.555												
600	23	13	10	9	9	8	10	8	6	6	6	6
700	31	18	13	12	11	11	14	12	9	9	9	9
800	41	23	17	15	14	14	18	16	13	12	12	11
900	51	28	20	18	17	17	23	20	16	15	15	14
1000	62	34	24	22	21	21	28	25	19	18	18	18
1100	72	39	27	24	23	22	32	28	22	20	20	20
1200	82	43	29	25	24	23	35	30	23	21	21	20
1300	93	46	30	26	24	23	38	32	23	21	21	20
1450	110	52	32	27	25	24	43	35	24	22	21	21

* The LPG charts are based on propane, but may also be used for butane.

Screwed		Flanged	
R 1	W-MF 512	DN 65	DMV 5065/12
R 1½	W-MF 512	DN 80	DMV 5080/12
R 2	DMV 525/12	DN 100	DMV 5100/12
		DN 125	VG 40.125

Stated flow pressures are based on a combustion chamber resistance of 0 mbar. The combustion chamber pressure of the heat generator must be added to the figure determined from the above chart when sizing the gas valve train. Minimum flow pressure 15 mbar.

For low-pressure supplies, EN 88-compliant governors with safety diaphragms are used.

For high-pressure supplies, an EN 334-compliant high-pressure regulator should be selected from the following technical booklets:

- Regulators up to 4 bar, Print No. 83001202
- Regulators with safety devices, Print No. 83197902

Refer to the burner's rating plate for the maximum connection pressure.

WM-G(L)20/3-A, version ZM(-T)-3LN (multiflam®)												
Burner rating kW	Low pressure supply (with FRS) (flow pressure in mbar into shut-off valve, $P_1 \leq 300$ mbar)						High pressure supply (with HP regulator) (flow pressure in mbar into gas valve assembly)					
	Nominal valve train diameter 1" 1½" 2" 65 80 100 125						Nominal valve train diameter 1" 1½" 2" 65 80 100 125					
	Nominal diameter of gas butterfly 65 65 65 65 65 65						Nominal diameter of gas butterfly 65 65 65 65 65 65					
Natural gas E LHV = 10.35 kWh/Nm³; d = 0.606												
950	103	42	21	15	13	12	32	24	13	10	10	9
1000	114	47	23	17	15	14	36	28	15	12	11	11
1100	139	58	29	22	19	17	45	35	19	16	15	14
1200	166	69	34	26	22	21	54	42	23	19	18	17
1300	194	81	40	30	26	24	64	49	27	23	22	21
1400	225	93	46	34	30	27	74	57	32	27	25	24
1500	255	104	50	36	31	28	82	63	34	28	26	25
1600	286	114	53	38	32	29	90	68	35	28	26	25
1800	-	138	61	41	33	29	108	80	38	30	27	25
2000	-	164	69	45	35	30	128	93	42	31	28	26
Natural gas LL LHV = 8.83 kWh/Nm³; d = 0.641												
950	146	58	26	18	15	14	44	33	16	12	11	10
1000	162	64	30	21	18	16	50	37	18	14	13	12
1100	197	79	37	26	22	20	62	46	24	19	18	17
1200	235	94	44	32	27	24	74	56	29	24	22	21
1300	276	111	52	37	32	29	88	66	35	28	26	25
1400	-	127	59	42	36	32	101	76	39	32	30	28
1500	-	142	65	45	37	33	112	84	42	33	31	29
1600	-	158	70	47	39	34	125	93	44	35	32	29
1800	-	194	81	53	42	36	-	111	50	37	34	31
2000	-	233	94	59	46	38	-	131	56	41	36	33
LPG* LHV = 25.89 kWh/Nm³; d = 1.555												
950	48	23	14	12	11	10	17	14	9	8	8	7
1000	53	25	16	13	12	12	19	16	10	9	9	9
1100	64	31	19	16	15	14	24	20	13	12	11	11
1200	76	37	22	19	18	17	29	24	16	15	14	14
1300	89	43	26	22	20	19	34	28	19	17	17	16
1400	103	49	30	25	23	22	40	33	22	20	20	19
1500	116	54	32	27	25	23	44	36	24	22	21	20
1600	129	59	34	27	25	24	47	38	25	22	21	20
1800	158	68	37	29	26	24	55	43	26	23	22	21
2000	190	79	40	30	26	24	63	49	28	23	22	21

Description	WM-L20 T-3LN	WM-G20 ZM-3LN	WM-GL20 ZM-T-3LN
Burner housing, hinged flange, housing cover, Weishaupt burner motor, air inlet housing, fan wheel, combustion head, ignition unit, ignition cable, ignition electrodes, combustion manager with control unit, flame sensor, actuators, flange gasket, limit switch on hinged flange, fixing screws	●	●	●
Digital combustion manager W-FM 50 W-FM 54	● -	● -	- ●
Valve proving via the combustion manager	-	●	●
Class-A double gas valve assembly	-	●	●
Gas butterfly valve	-	●	●
Air pressure switch	○	●	●
Low gas pressure switch	-	●	●
Preset, capacity-based mixing assembly	●	●	●
Actuators for compound regulation of fuel and air via W-FM: Air damper actuator Gas butterfly valve actuator	● -	● ●	● ●
Oil pump fitted to burner	●	-	●
Oil hoses	●	-	●
3 oil solenoid valves, three-stage nozzle head with preinstalled oil nozzles, 1 additional oil safety solenoid valve	●	-	●
DOL motor contactor fitted to motor ¹⁾	●	●	●
IP 54 protection	●	●	●

EN 676 stipulates that ball valves, gas filters, and gas pressure regulators form part of the burner supply (see Weishaupt accessories list). Please enquire or see the special equipment section of this brochure for further burner executions.

- Standard
- Optional

¹⁾ The necessary motor protection can be provided either by a motor protection switch (supplied and fitted into a panel by others), or with integral motor overload protection (see special equipment).

Order numbers

Special equipment WM-L20, version 3LN (multiflam®)

Oil burners

Burner type	Version	Order No.
WM-L20/2-A	T-3LN	211 210 24
WM-L20/3-A	T-3LN	211 210 34

DIN CERTCO: 5G1031/12

Gas burners

Burner type	Version	Valve train size	Order No.
WM-G20/2-A	ZM-3LN	R 1	217 215 11
		R 1½	217 215 12
		R 2	217 215 13
		DN 65	217 215 14
		DN 80	217 215 15
		DN 100	217 215 16
		DN 125	217 215 17
WM-G20/3-A	ZM-3LN	R 1	217 216 11
		R 1½	217 216 12
		R 2	217 216 13
		DN 65	217 216 14
		DN 80	217 216 15
		DN 100	217 216 16
		DN 125	217 216 17

CE-PIN: CE 0085BQ0032

Dual-fuel burners

Burner type	Version	Valve train size	Order No.
WM-GL20/2-A	ZM-T-3LN	R 1	218 214 11
		R 1½	218 214 12
		R 2	218 214 13
		DN 65	218 214 14
		DN 80	218 214 15
		DN 100	218 214 16
		DN 125	218 214 17
WM-GL20/3-A	ZM-T-3LN	R 1	218 217 11
		R 1½	218 217 12
		R 2	218 217 13
		DN 65	218 217 14
		DN 80	218 217 15
		DN 100	218 217 16
		DN 125	218 217 17

CE-PIN: CE 0085BT0133
DIN CERTCO: 5G1032/M

Oil burners, version T-3LN	WM-L20/2-A	WM-L20/3-A
Pressure gauge with ball valve	110 000 79	110 000 79
Vacuum gauge with ball valve	110 005 69	110 005 69
Combustion head extension	by 100 mm	210 031 36
	by 200 mm	210 031 37
	by 300 mm	210 031 38
Oil hoses, 1300 mm in lieu of 1000 mm	110 000 72	110 000 72
Two-stage operation with low-impact start or changeover	210 030 31	210 030 31
Solenoid valve for air pressure switch test with continuous-run fan or post purge	250 030 21	250 030 21
Air inlet flange for ducted-air connection, with LGW10 air pressure switch (LGW 50 also required)	210 030 47	210 030 47
LGW 50 air pressure switch ³⁾	210 030 08	210 030 08
Oil meter ²⁾	< 150 kg VZO8	210 030 42
	> 150 kg VZO20	210 030 44
ST 18/7 and ST 18/4 plug connections (W-FM 50 / 100 / 200)	210 030 13	210 030 13
ST 18/7 plug connection (W-FM 50 with KS20)	250 031 06	250 031 06
Burner-mounted KS20 controller (W-FM 50)	250 033 15	250 033 15
W-FM 100 (suitable for continuous firing) ³⁾ in lieu of W-FM 50	burner-mounted	210 030 32
	supplied loose	210 030 88
Integral load controller and analogue signal convertor for W-FM 100	110 017 18	110 017 18
W-FM 200 in lieu of W-FM 50 with integral load controller, analogue signal convertor, and VSD module, with optional fuel metering	210 030 10	210 030 10
DSB 158 oil pressure switch in supply ³⁾	210 030 46	210 030 46
QRI flame sensor in lieu of QRA ³⁾	210 030 24	210 030 24
WM-D112 motor with 230 V contactor and overload protection ¹⁾	250 030 95	250 030 95
ABE with Chinese-character display, supplied loose (W-FM 100 / 200)	110 018 53	110 018 53
Special voltage (on application only)	Please enquire	Please enquire
110 V control voltage	Please enquire	Please enquire

Country-specific executions and special voltages on application

¹⁾ The necessary motor protection can be provided either by a motor protection switch (supplied and fitted into a panel by others), or with integral motor overload protection (see special equipment).

²⁾ Please enquire regarding oil meter with low or high-frequency transmitter.

³⁾ Required for PED (2014/68/EU) compliance.

Special equipment WM-G20 and WM-GL20, vers. 3LN (multiflam®)

Gas and dual-fuel burners, versions ZM-3LN and ZM-T-3LN		WM-G20/2-A	WM-G20/3-A	WM-GL20/2-A	WM-GL20/3-A
Pressure gauge with ball valve		–	–	110 000 79	110 000 79
Vacuum gauge with ball valve		–	–	110 005 69	110 005 69
Combustion head extension	by 100 mm	250 032 77	250 032 77	250 032 80	250 032 80
	by 200 mm	250 032 78	250 032 78	250 032 81	250 032 81
	by 300 mm	250 032 79	250 032 79	250 032 82	250 032 82
High gas pressure switch ⁴⁾ (Screwed W-MF / DMV for low-press. supplies)	GW 50 A6/1	250 033 30	250 033 30	250 033 30	250 033 30
	GW 150 A6/1	250 033 31	250 033 31	250 033 31	250 033 31
	GW 500 A6/1	250 033 32	250 033 32	250 033 32	250 033 32
High gas pressure switch ⁴⁾ (Flanged DMV/VGD for low-pressure supplies)	GW 50 A6/1	150 017 49	150 017 49	150 017 49	150 017 49
	GW 150 A6/1	150 017 50	150 017 50	150 017 50	150 017 50
	GW 500 A6/1	150 017 51	150 017 51	150 017 51	150 017 51
High gas pressure switch ⁴⁾ (Fitted to high-pressure regulator)	GW 50 A6/1	250 033 33	250 033 33	250 033 33	250 033 33
	GW 150 A6/1	250 033 34	250 033 34	250 033 34	250 033 34
	GW 500 A6/1	250 033 35	250 033 35	250 033 35	250 033 35
Oil hoses, 1300 mm in lieu of 1000 mm		–	–	110 000 72	110 000 72
Electromagnetic clutch		–	–	250 031 16	250 031 16
Air inlet flange for ducted-air connection, with LGW air pressure switch		210 030 47	210 030 47	210 030 47	210 030 47
Oil meter ²⁾	< 150 kg	VZ08	–	250 031 33	250 031 33
	> 150 kg:	VZ020	–	250 031 34	250 031 34
Plug connection(s)	ST 18/7 and ST 18/4 (W-FM 50 / 100 / 200)	250 030 22	250 030 22	250 030 22	250 030 22
	ST 18/7 (W-FM 50 with KS20)	250 031 06	250 031 06	–	–
	ST 18/7 and ST 18/4 (W-FM 54)	–	–	250 031 99	250 031 99
	ST 18/7 (W-FM 100 / 200)	–	–	250 032 01	250 032 01
Burner-mounted KS20 controller (W-FM 50)		250 033 15	250 033 15	–	–
W-FM 100 (suitable for continuous firing) ⁴⁾ in lieu of W-FM 50	burner-mounted	250 030 74	250 030 74	–	–
	supplied loose	250 031 43	250 031 43	–	–
W-FM 100 (suitable for continuous firing) ⁴⁾ in lieu of W-FM 54 with integral load controller and analogue signal convertor	burner-mounted	–	–	250 033 67	250 033 67
	supplied loose	–	–	250 033 68	250 033 68
Integral load controller and analogue signal convertor for W-FM 100		110 017 18	110 017 18	Standard	Standard
W-FM 200 in lieu of W-FM 50 with integral load controller, analogue signal convertor, and VSD module, with optional fuel metering	burner-mounted	250 030 75	250 030 75	–	–
	supplied loose	250 030 48	250 030 48	–	–
W-FM 200 in lieu of W-FM 54 with integral load controller, analogue signal convertor, and VSD module with optional fuel metering	burner-mounted	–	–	250 033 69	250 033 69
	supplied loose	–	–	250 033 70	250 033 70
DSB 158 oil pressure switch in supply ⁴⁾		–	–	210 030 46	210 030 46
QRA 73 flame sensor in lieu of QRA 2 ⁴⁾		–	–	210 031 63	210 031 63

Gas and dual-fuel burners, versions ZM-3LN and ZM-T-3LN	WM-G20/2-A	WM-G20/3-A	WM-GL20/2-A	WM-GL20/3-A
VSD with integral frequency convertor (W-FM 50 / 54 / 200 required)	210 030 40	210 030 40	210 030 40	210 030 40
VSD with separate frequency convertor (W-FM 200 required) (See accessories list for frequency convertor)	210 030 41	210 030 41	210 030 41	210 030 41
W-FM 200 with extended O ₂ trim / CO control functionality	250 033 78	250 033 78	250 033 78	250 033 78
WM-D112 motor with 230 V contactor and overload protection ³⁾	250 030 95	250 030 95	250 030 95	250 030 95
ABE with Chinese-character display, supplied loose (W-FM 100 / 200)	110 018 53	110 018 53	110 018 53	110 018 53
Control voltage	110 V (W-FM 50 / 100 / 200)	Please enquire	Please enquire	Please enquire
	110 V (W-FM 54)	Please enquire	Please enquire	Please enquire

Country-specific executions and special voltages on application

¹⁾ 100 % speed is recommended for non-modulating oil side operation.

²⁾ Please enquire regarding oil meter with low or high-frequency transmitter.

³⁾ The necessary motor protection can be provided either by a motor protection switch (supplied and fitted into a panel by others), or with integral motor overload protection (see special equipment).

⁴⁾ Required for PED (2014/68/EU) compliance.

Technical data

WM 20, version 3LN (multiflam®)

Oil burners		WM-L20/2-A T-3LN	WM-L20/3-A T-3LN
Burner motor	Weishaupt type	WM-D112/140-2/3K0	WM-D112/170-2/4K5
Motor power output	kW	3.0	4.5
Nominal current	A	6.5	9.2
Motor protection switch ¹⁾ or motor prefusing ¹⁾ (with overload protection)	type (e. g.) A minimum	PKE12/XTU-12 25 A gG / T (by others)	PKE12/XTU-12 35 A gG / T (by others)
Speed (50 Hz)	rpm	2950	2930
Combustion manager	type	W-FM 50	W-FM 50
Flame monitoring	type	QRA 2	QRA 2
Integral pump	type	J6	J6
max. flow rate	l/h	290	290
NO _x Class per EN 267		3	3
Oil hoses	DN / length	13 / 1000	13 / 1000
Mass	kg	approx. 107	approx. 115

Gas burners		WM-G20/2-A ZM-3LN	WM-G20/3-A ZM-3LN
Burner motor	Weishaupt type	WM-D112/140-2/3K0	WM-D112/170-2/4K5
Motor power output	kW	3.0	4.5
Nominal current	A	6.5	9.2
Motor protection switch ¹⁾ or motor prefusing ¹⁾ (with overload protection)	type (e. g.) A minimum	PKE12/XTU-12 25A gG / T (by others)	PKE12/XTU-12 35A gG / T (by others)
Speed (50 Hz)	rpm	2950	2930
Combustion manager	type	W-FM 50	W-FM 50
Flame monitoring	type	ION	ION
Air damper / gas actuator	type	STE 50	STE 50
NO _x Class per EN 676		3	3
Mass (excl. double gas valve assembly and fittings)	kg	approx. 102	approx. 110

Dual-fuel burners		WM-GL20/2-A ZM-T-3LN	WM-GL20/3-A ZM-T-3LN
Burner motor	Weishaupt type	WM-D112/140-2/3K0	WM-D112/170-2/4K5
Motor power output	kW	3.0	4.5
Nominal current	A	6.5	9.2
Motor protection switch ¹⁾ or motor prefusing ¹⁾ (with overload protection)	type (e. g.) A minimum	PKE12/XTU-12 25 A gG / T (by others)	PKE12/XTU-12 35 A gG / T (by others)
Speed (50 Hz)	rpm	2950	2930
Combustion manager	type	W-FM 54	W-FM 54
Flame monitoring	type	QRA 2	QRA 2
Air damper / gas actuator	type	STE 50	STE 50
Integral pump	type	J6	J6
max. flow rate	l/h	290	290
NO _x Class per EN 676 / EN 267		3	3
Oil hoses	DN / length	13 / 1000	13 / 1000
Mass (excl. double gas valve assembly and fittings)	kg	approx. 112	approx. 120

¹⁾ The necessary motor protection can be provided either by a motor protection switch (supplied and fitted into a panel by others), or with integral motor overload protection (see special equipment).

Voltages and frequencies:
The burners are equipped as standard for three-phase alternating current, 400 V, 3 ~, 50 Hz. Other voltages and frequencies are available on application.

Standard burner motor:
Insulation Class F, IP 55 protection.
IE3 Premium Efficiency.

Dimensions

multiflam® oil burners, version 3LN

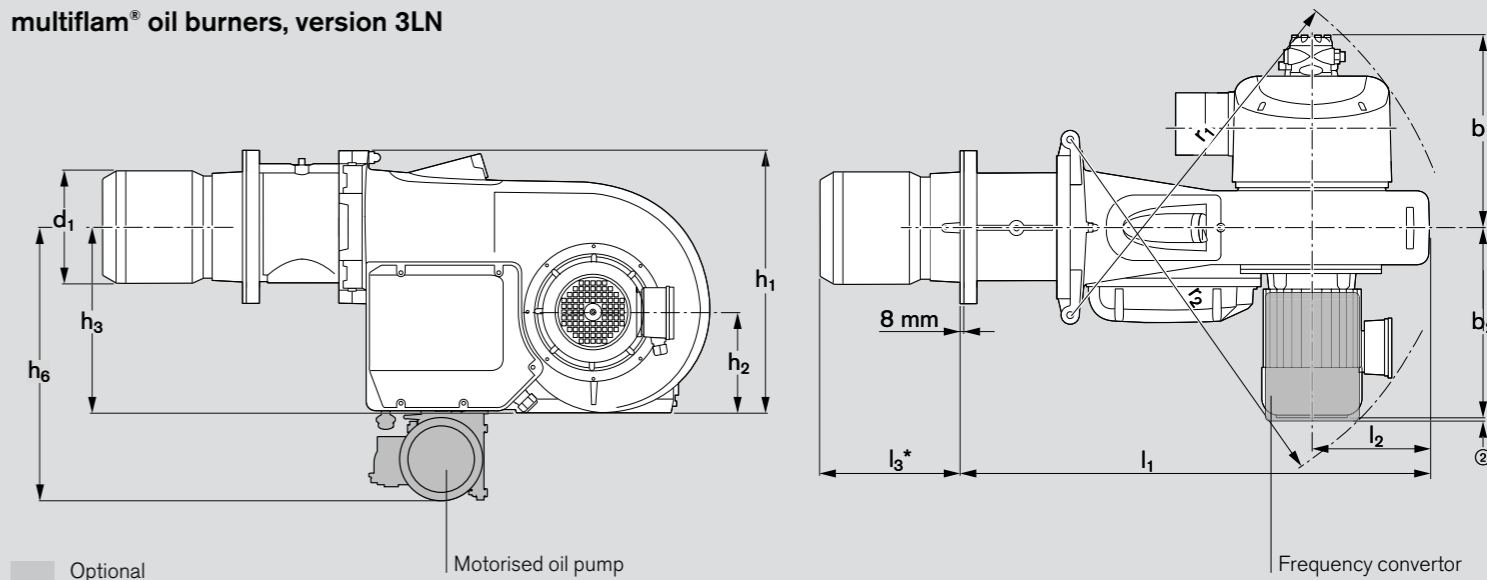

Burner type	Dimensions in mm												
	l ₁	l ₂	l ₃	b ₁	b ₂	h ₁	h ₂	h ₃	h ₆	r ₁	r ₂	d ₁	
WM-L20/2-A T-3LN	1010	254	295-310	411	424	573	225	408	567	840	869	242	
WM-L20/3-A T-3LN	1010	254	295-320	411	447	573	225	408	574	840	883	242	

① Excluding electromagnetic clutch (pump with electromagnetic clutch: plus 130 mm)
② Projection of frequency converter approx. 20 mm

multiflam® gas burners, version 3LN

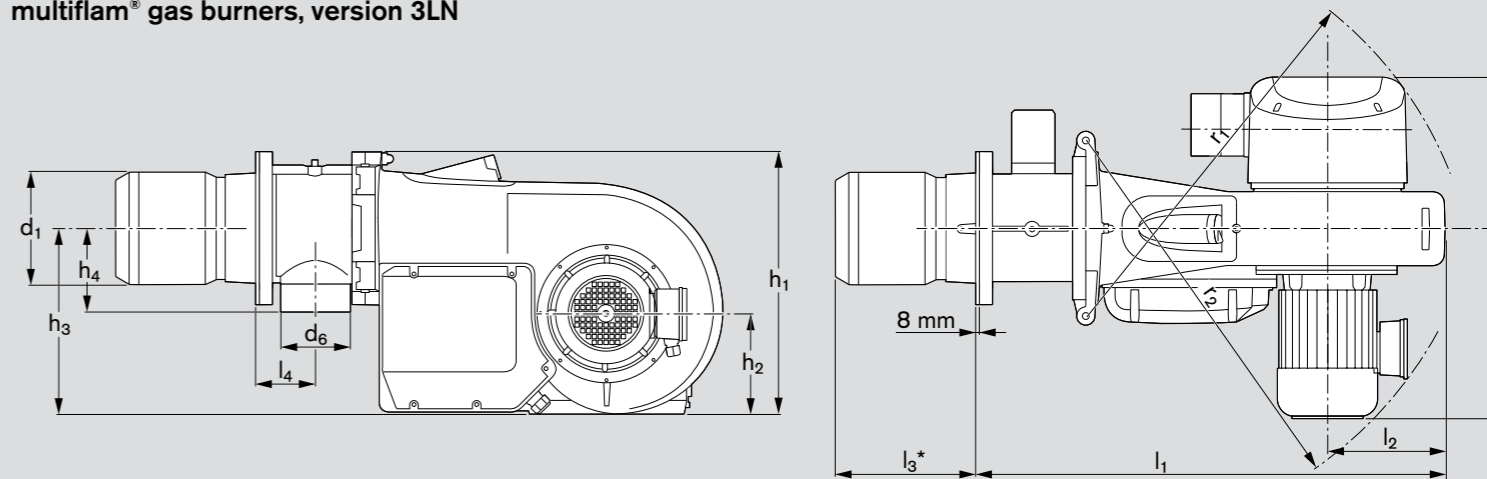

Burner type	Dimensions in mm													
	l ₁	l ₂	l ₃	l ₄	b ₁	b ₂	h ₁	h ₂	h ₃	h ₄	r ₁	r ₂	d ₁	d ₆
WM-G20/2-A ZM-3LN	1010	254	295 - 310	128	326	424	573	225	408	182	840	869	242	DN65
WM-G20/3-A ZM-3LN	1010	254	295 - 320	128	326	447	573	225	408	182	840	883	242	DN65

All dimensions are approximate.
Weishaupt reserve the right to make changes in light of future developments.

Dimensions

multiflam® dual-fuel burners, version 3LN

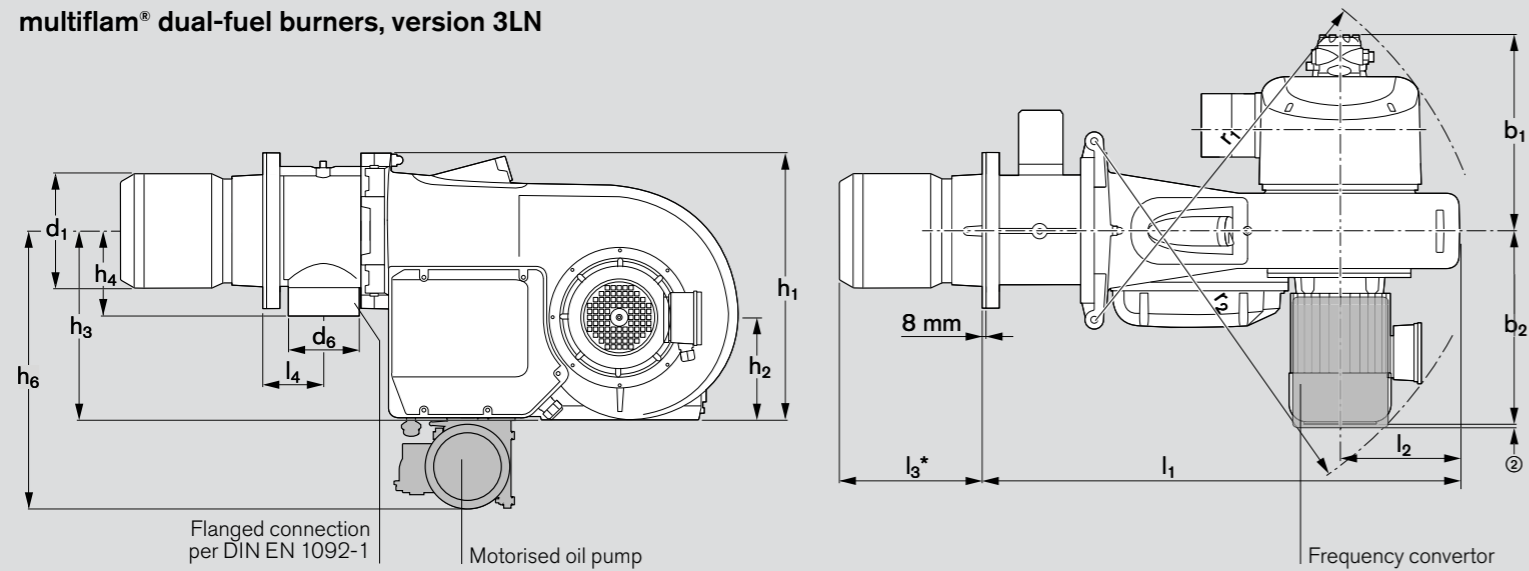

Burner type	Dimensions in mm			l ₄	b ₁	b ₂	h ₁	h ₂	h ₃	h ₄	h ₆	r ₁	r ₂	d ₁	d ₆
	l ₁	l ₂	l ₃ ^①												
WM-GL20/2-A ZM-T-3LN	1010	254	295-310	128	411	424	573	225	408	182	567	840	869	242	DN65
WM-GL20/3-A ZM-T-3LN	1010	254	295-325	128	411	447	573	225	408	182	574	840	883	242	DN65

① Excluding electromagnetic clutch (pump with electromagnetic clutch: plus 130 mm)
 ② Projection of frequency converter approx. 20 mm

All dimensions are approximate. Weishaupt reserve the right to make changes in light of future developments.

Mounting-plate drilling dimensions

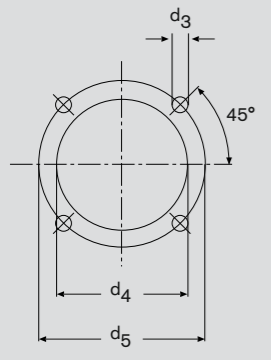

d₃ = M12
 d₄ = 270 mm
 d₅ = 298 mm

Heat generator preparation

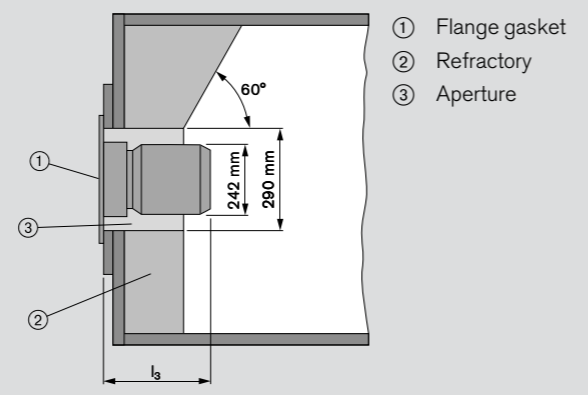

The leading edge of the combustion head must protrude approx. 50 mm beyond the refractory ②. The refractory may be tapered (min. 60°).

Fuel systems

Gas-side fuel system

W-FM 50 / 100 / 200

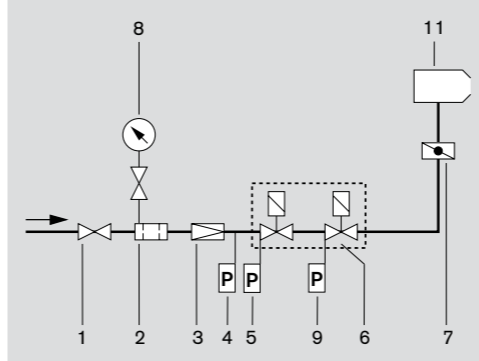

- 1 Ball valve *
- 2 Gas filter *
- 3 Pressure regulator, (LP) or (HP) *
- 4 High gas pressure switch *
- 5 Low gas pressure switch
- 6 Double gas valve assembly
- 7 Gas butterfly valve
- 8 Pressure gauge with push-button valve *
- 9 Valve-proving pressure switch
- 10 Low gas / valve-proving pressure switch
- 11 Burner

W-FM 54

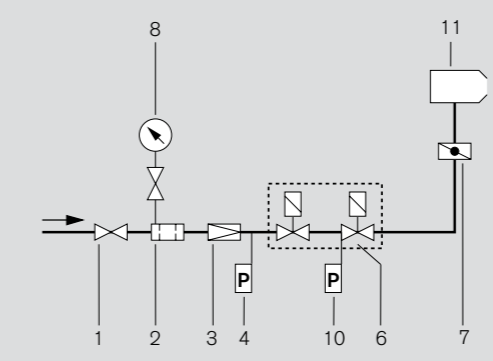

* Not included in burner price
 Mounting position of the high gas pressure switch:
 On the regulator outlet of HP trains
 After the regulator of screwed LP trains
 On the valve assembly inlet of flanged LP trains
 Cable length approx. 2.5 m.

Oil-side fuel system

Version (ZM-)T-3LN:

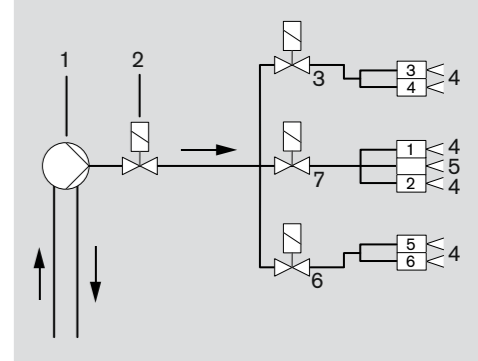

- 1 Burner-mounted oil pump
- 2 Safety solenoid valve
- 3 Solenoid valve, secondary nozzles 3 and 4
- 4 Secondary nozzles
- 5 Primary nozzle
- 6 Solenoid valve, secondary nozzles 5 and 6
- 7 Solenoid valve, primary nozzle and secondary nozzles 1 and 2

Layout of the valve train

On boilers with hinged doors, the valve train must be mounted on the opposite side to the boiler-door hinges.

Compensator

To enable a tension free mounting of the valve train, the fitting of a compensator is strongly recommended.

Break points in the valve train

Break points in the valve train should be provided to enable the door of the heat generator to be swung open. The main gas line is best separated at the compensator.

Support of the valve train

The valve train should be properly supported in accordance with the site conditions. See the Weishaupt accessories list for various valve train support components.

Gas meter

A gas meter must be installed to measure gas consumption during commissioning and servicing.

Optional thermal shutoff (when required by local regulations)

Integrated into the ball valve of screwed valve trains. A separate component with HTB seals fitted before the ball valve on flanged valve trains.

Contact Us



Maximising Energy Efficiencies for a Sustainable Future

admin@egl.com.au

www.environmental.com.au

03 9541 8699

Office Locations



Melbourne

Tomlinson Energy Services
Suite 2.01 | Level 2
315 Ferntree Gully Road
Mount Waverley VIC 3149

P: 03 8560 0416

E: energyservice.melbourne@tomlinsonenergy.com.au

Sydney

Tomlinson Energy Services
A2, 26 Power Road
Seven Hills NSW 2417

P: 02 9681 4177

E: energyservice.sydney@tomlinsonenergy.com.au

Brisbane

Tomlinson Energy Services
1/48 Commerce Circuit
Yatala QLD 4207

P: 07 3462 0159

E: energyservice.brisbane@tomlinsonenergy.com.au

South Australia

Tomlinson Energy Services
26 Phillips Street
Thebarton SA 5031

P: 08 8297 9688

E: energyservice.adelaide@tomlinsonenergy.com.au

Western Australia

Tomlinson Energy Services
40 Sorbonne Crescent
Canning Vale WA 6155

P: 08 9455 5511

E: energyservice.perth@tomlinsonenergy.com.au



**The Environmental
Group Limited**
Engineering a Sustainable Future