



High-Performance Packaged Boiler

Australia's largest certified
package boiler company.



**The Environmental
Group Limited**
Engineering a Sustainable Future

The Environmental Group Limited

www.environmental.com.au

Working across the Circular Economy

Our Purpose

Engineering a sustainable future.

Our Mission

To enable our clients to contribute to a cleaner environment by safely delivering pivotal solutions while generating value for our shareholders, staff, and partner industries.

Our Team

Our local experts are dedicated to reducing waste and boosting energy performance. Trusted worldwide to provide the highest standards of service and support.

Tomlinson Energy Services

Part of The Environmental Group

Tomlinson Energy Services is Australia's leading provider of packaged boiler solutions, delivering the highest combustion efficiency to keep operating costs low and performance high.

We specialise in custom design, installation, commissioning, and national servicing and repairs, complemented by our 24/7 emergency support.

With offices and a dedicated service team across Australia, Tomlinson Energy Services ensures boilers operate at peak performance for maximum efficiency and reliability.



WM 30 MONARCH® BURNERS POWERFUL AND VERSATILE (350–6200 KW)



–weishaupt–

Offering Industry Leading Burners

Weishaupt produces gas and oil-fired boilers, heat pumps, and burners. These top-quality products are characterised by their meticulous development, high-quality workmanship, outstanding operational reliability, and maximum Efficiency. Their unrivalled excellence extends equally to design and function.

Progress and tradition: The latest monarch[®] burner



The monarch[®] trademark has stood for power and quality for more than 60 years

For more than six decades, Weishaupt's monarch[®] series burners have been used on a wide variety of heat generators and industrial plant, and their success has helped underpin Weishaupt's outstanding reputation.

The latest monarch[®] series is writing the next chapter in this success story. The combination of state-of-the-art equipment and a compact design makes these powerful burners suitable for a wide range of applications.

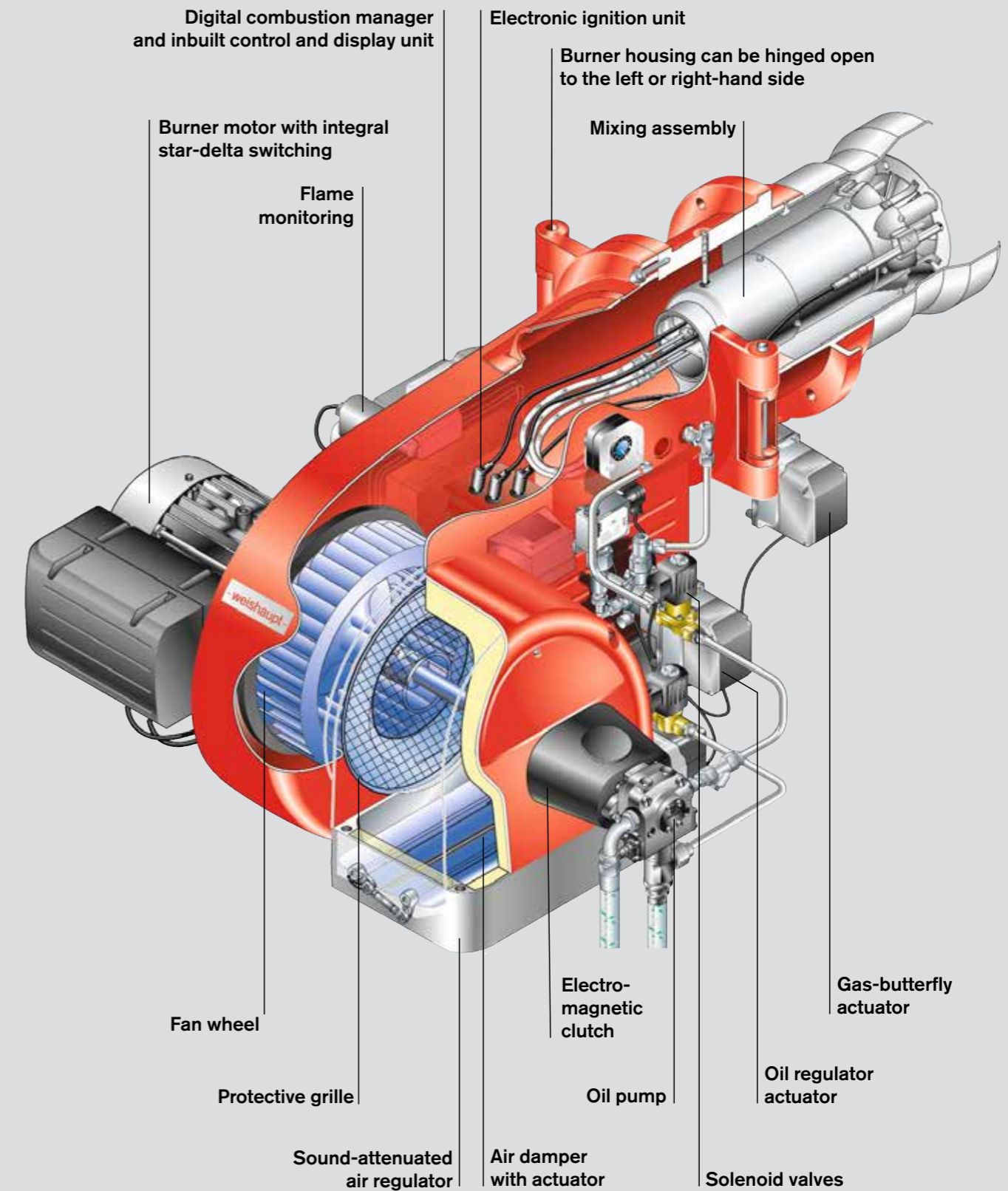

WM-GL30, version ZM-R

Digital

Digital combustion management means optimal combustion figures, continuously reproducible setpoints, and ease of use.

Weishaupt WM 30-series burners are equipped as standard with electronic compound regulation and digital combustion management. Modern combustion technologies demand a precise and continually reproducible dosing of fuel and combustion air. This optimises combustion efficiency and saves fuel.

Simple operation

Setting and control of the burner is achieved using a control and display unit. This is linked to the combustion manager via a bus system, enabling the user-friendly setting of the burner.

Flexible communication options

The integrated interface enables all necessary data and functions to be relayed to a master control system. If required, a modem can be installed to allow for remote operation, monitoring, and diagnosis.

Bus communication with external controls and building management

Several bus systems are available if data from the burner are to be exchanged with a PLC unit, or if control of the burner is to be integrated with a building management system.

For the control and management levels, Weishaupt offers ProGraf NT, a real-time software product that meets any and all requirements.

Technological edge

Digital combustion management makes burner operation simple and reliable. The most important advantages:

- No additional burner controls are necessary as control is effected by the combustion manager. The only additional requirements are a motor protection switch for the burner motor and external control fuses.
- Reduced installation expense. Each burner is factory tested and supplied as a complete unit.
- Commissioning and servicing takes less time. The burner's basic parameters are set at the factory. The combustion manager's menu-driven commissioning program is used to run through the final site-specific adjustments and the combustion emission checks.

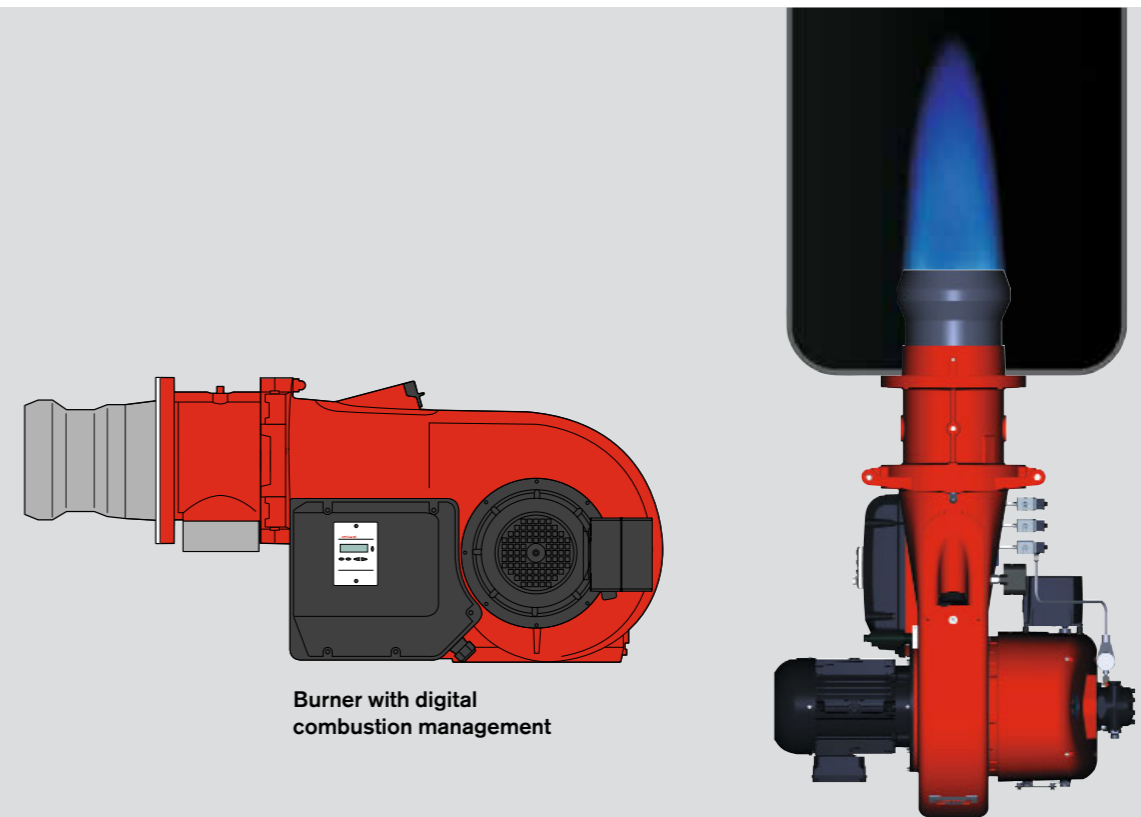

Burner with digital combustion management

Digital combustion management Features	W-FM 50	W-FM 54	W-FM 100	W-FM 200
Single-fuel operation	●	–	●	●
Dual-fuel operation	–	●	●	●
Intermittent firing	●	●	●	●
Continuous firing >24 h	● ²⁾	–	●	●
Flame sensor for intermittent firing	ION/QRA2/QRB	QRA2	ION/QRI/QRB/QRA	ION/QRI/QRB/QRA
Flame sensor for continuous firing	ION	–	ION/QRI/QRA 73	ION/QRI/QRA 73
Maximum number of actuators	2	3	4	6
Actuators with stepping motors	●	●	●	●
VSD available	●	●	–	●
O ₂ trim available	–	–	–	●
Gas valve proving	●	●	●	●
4–20 mA input signal	●	●	○	●
Integrated, self-checking PID controller for temperature or pressure, 0/2–10 V and 0/4–20 mA included	–	–	○	●
Removable ABE control unit (max. length of connecting line)	20 m	20 m	100 m	100 m
Fuel consumption meter (switchable)	● ¹⁾	● ¹⁾	–	●
Combustion efficiency display in conjunction with O ₂ trim	–	–	–	●
eBUS / Modbus RTU interface	●	●	●	●
PC-supported commissioning	●	●	●	●

● Standard
○ Optional

Please enquire regarding connections available for additional functions, e.g. flue gas dampers, oil shutoff assemblies, etc.

¹⁾ Not in conjunction with VSD

²⁾ Gas burner with ionisation probes only

ZM-R version

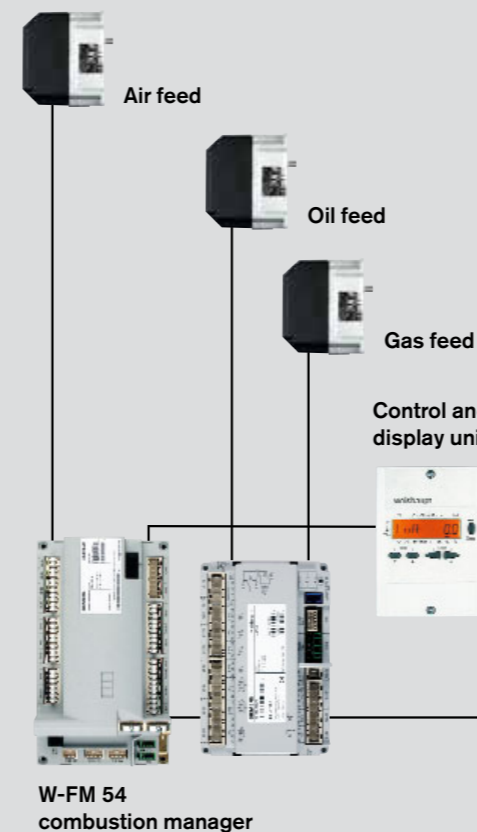

ZM-T version

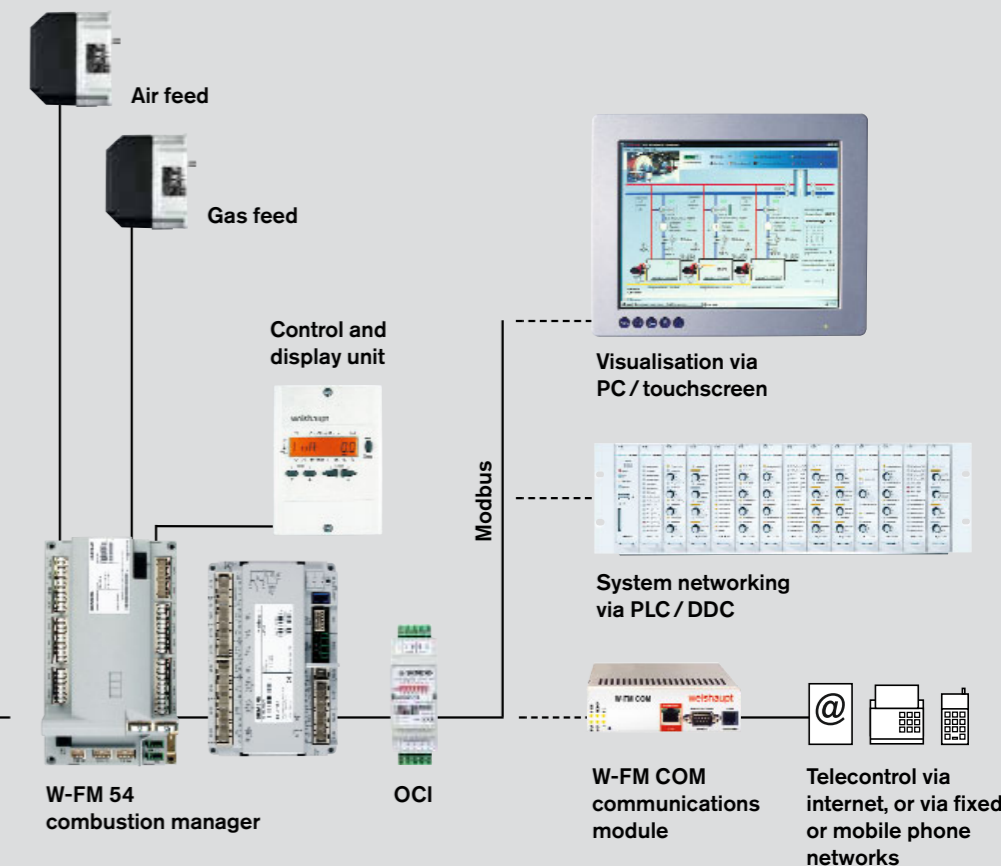

Schematic representation with W-FM 54

Compact and quiet

The latest Weishaupt WM-series monarch® burners are compact, powerful, and quiet. They are writing the next chapter in the 60-year-long success story of the legendary monarch® series.

Futuristic fan technology

From the very earliest stages of burner development, particular emphasis was placed on a compact, aerodynamic design and low operational noise levels.

To realise this goal a completely new air inlet and air damper control were developed. This special housing design with its self-opening air inlet and the new air-damper technology result in increased fan pressure and thus in greater capacity despite the burner's more compact form.

Air damper control provides a high degree of linearity even at the lower end of the burner's operating range and, combined with the sound-attenuated air inlet which is included as standard, ensures quieter operation.

Fast commissioning, simple servicing

All WM 30 burners are delivered with the mixing assembly preset for the required output of the burner. A final adjustment is made using the combustion manager's menu-controlled commissioning program.

All of the burner's components, such as the mixing assembly, air damper, and combustion manager, are readily accessible despite its compact form. This enables maintenance and servicing work to be carried out quickly and easily, aided by the standard hinged flange which provides a perfect servicing position.

Adjustment to suit different combustion chamber conditions can easily be made with the burner in its installed position. The integral sightglass enables ignition behaviour and the flame to be observed.

Control

The following methods of regulation are available for Weishaupt WM 30 burners:
Gas: Sliding-two-stage or modulating (ZM), depending on the method of load control employed.

Oil: Three-stage or two-stage with low-impact start or changeover (T). Sliding-two-stage or modulating (R), depending on the method of load control employed.

The output of a modulating burner is matched – within its operating range – to current heat demand.

These multiple control options make the burner suitable for a wide range of applications and ensure a gentle and problem-free start up, along with a high degree of operational reliability.

Various burner versions are available to meet differing emission limits and operational requirements:

ZM version

Burners with the standard, advanced-design mixing assembly for installations with Class 2 oil and gas-side NO_x emission limits.

LN version

Low-NO_x gas burners for installations with Class 3 NO_x emission limits. The reduction in NO_x is achieved through a more intensive recirculation of the combustion gases in the combustion chamber. Good emissions depend on combustion chamber geometry, thermal loading and on the combustion system (three-pass or reverse-flame).

3LN version

Low-NO_x gas, oil, and dual-fuel burners with multiflam® mixing assemblies that generate emissions below Class 3 NO_x limits for both gas and oil. The burners' very low NO_x emissions are achieved using a special fuel distribution system. 3LN-version burners can fire natural gas, LPG, or light oil, and are suitable for use on three-pass and through-pass boilers.

Reduced NO_x emissions with flue gas recirculation (gas burners)

Where stringent emission limits for oxides of nitrogen are in force, Weishaupt's multiflam® mixing assemblies for gas-fired burners can be combined with flue gas recirculation. Weishaupt takes advantage of the special properties of the flame geometry, and with it the adaption to the combustion chamber, to reduce NO_x levels.

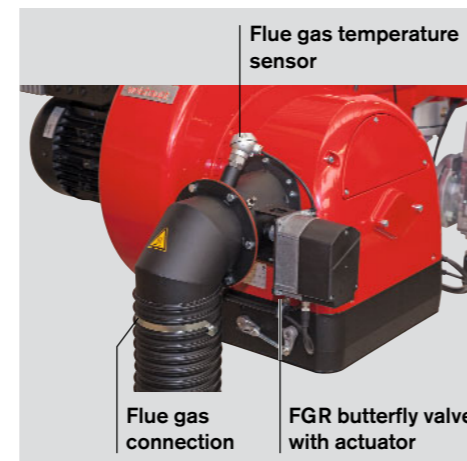

Air inlet housing with factory-preassembled flue gas recirculation components

Fuels

Natural gas
LPG
Light oil (35 s gas oil)
10 % biodiesel blends (B10)

The suitability of fuels of differing quality must be confirmed in advance with Weishaupt.

Applications

Weishaupt WM 30 burners are suitable for intermittent firing and continuous firing on:

- EN 303-compliant heat generators
- LTHW boilers
- HTHW boilers
- Steam boilers
- Air heaters
- Certain process applications

Permissible ambient conditions

- Ambient temperature
-15 to + 40 °C for gas firing
-10 to + 40 °C for oil firing
- Maximum 80 % relative humidity, no condensation
- The combustion air must be free of aggressive substances (halogens, chlorides, fluorides etc.) and impurities (dust, debris, vapours, etc.)
- Adequate ventilation is required for operation in enclosed spaces
- For plant in unheated areas, certain further measures may be required

Use of the burner for other applications or in ambient conditions not detailed above is not permitted without the prior written agreement of Max Weishaupt GmbH. Service intervals will be reduced in accordance with the more extreme operational conditions.

Protection Class

IP 54 per EN 60529.

Standards compliance

The burners are tested by an independent body and fulfil the applicable requirements of the following European Union directives and applied standards:

EMC EMC Directive

- 2014/30/EU
- Applied standards:
 - EN 61000-6-1 : 2007
 - EN 61000-6-2 : 2005
 - EN 61000-6-4 : 2007

LVD Low Voltage Directive

- 2014/35/EU
- Applied standards:
 - EN 60335-1 : 2010
 - EN 60335-2-102 : 2010

MD Machinery Directive

- 2006/42/EC
- Applied standards:
 - EN 267 Annex J,
 - EN 676 Annex J,

GAD Gas Appliance Directive

- 2009/142/EC
- Applied standards:
 - EN 676 : 2008

PED¹⁾ Pressure Equipment Directive

- 2014/68/EU
- Applied standards:
 - EN 267 Annex K,
 - EN 676 Annex K,
 - Conformity assessment procedure: Module B

The burners are labelled with

- CE Mark,
- CE-PIN per 2009/142/EC
- Identification No. of the notified body

¹⁾ With the appropriate choice of equipment.

The most important advantages:

- Easy changeover between gas and oil on dual-fuel burners
- Digital combustion management with electronic compound regulation at all ratings
- Compact design
- Sound-attenuated air inlet as standard for quieter operation
- Powerful fan with specially developed fan geometry and air damper control
- All WM 30 burners are delivered with the mixing assembly preset for the required output of the burner
- IP 54 protection as standard
- Easy access to all components, such as the mixing assembly, air damper and combustion manager
- Reliable operation with three-stage, sliding-two-stage, or modulating operation, depending on the burner version and method of load control
- Computer-controlled function test of each individual burner at the factory
- Burners can be supplied with pre-wired plug connections
- Excellent price / capacity relationship
- Well-established, global service network

Trademark protection

Weishaupt WM 30 monarch® burners are registered as a Community Trade Mark throughout Europe.

Overview of burner control

Model designation

Oil-fired operation

Three-stage control (T)

- Oil is released during start up by the opening of solenoid valve 1 and the safety solenoid valve.
- Full load is reached by the opening of solenoid valves 2 and 3.
- Load control is achieved by opening and closing solenoid valves 2 and 3.

Sliding-two-stage or modulating control (R)

- On opening the solenoid valves the correct rate of oil for start up is released.
- An actuator sets the oil regulator to full load.
- Load control is achieved through the opening and closing of the oil regulator.
- Modulating operation:
 - W-FM 50 or W-FM 54 with KS20 controller
 - W-FM 100 with load controller
 - W-FM 200
- Alternatively, a PID controller can be fitted into the control panel

Three-stage

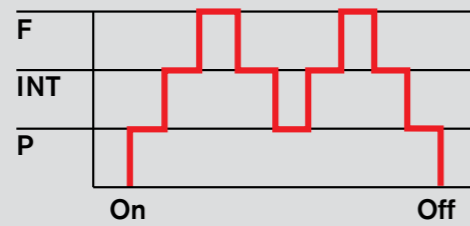

Sliding-two-stage

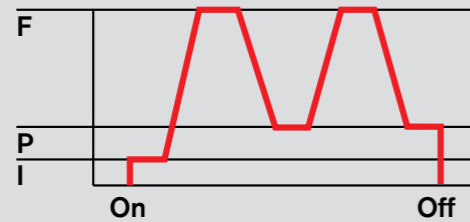

Modulating

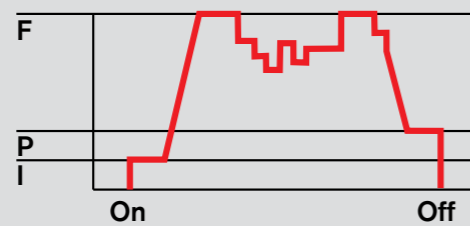

Gas-fired operation

Sliding-two-stage or modulating control (ZM)

- Actuators drive the burner to partial load or full load in response to heat demand.
- There is a gradual change between both load points. There are no sudden, large changes in fuel throughput.
- Modulating operation:
 - W-FM 50 or W-FM 54 with KS20 controller
 - W-FM 100 with load controller
 - W-FM 200
- Alternatively, a PID controller can be fitted into the control panel

- F = Full load (nominal load)
- INT = Intermediate load
- P = Partial load (minimum load)
- I = Ignition load

Fuel Version	Oil			Gas	
	three-stage	sliding-two-stage	modulating	sliding-two-stage	modulating
ZM				●	●
ZM-T	●			●	●
ZM-R		●	●	●	●

Model designation

WM - L 30 / 3 -A T ...R

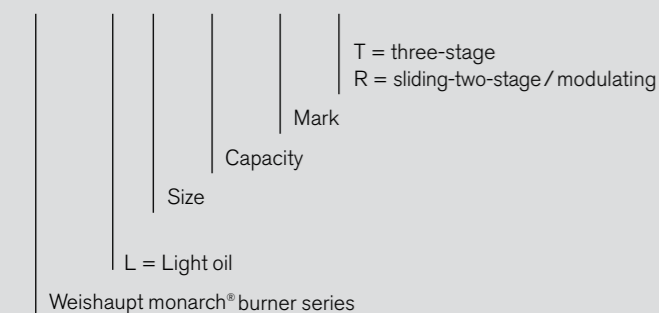

WM - GL 30 / 3 -A ZM - T ...ZM - R

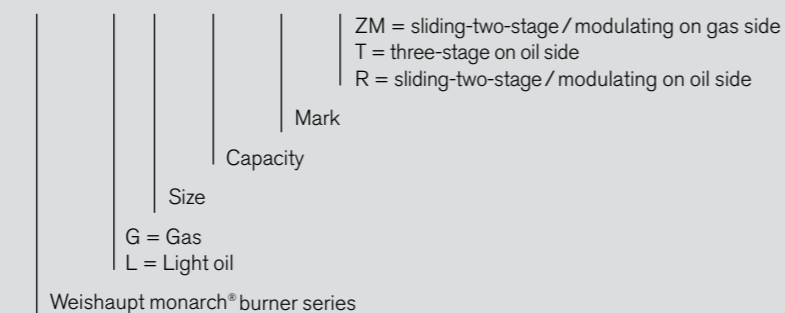

Burner selection

WM-L30, versions T and R

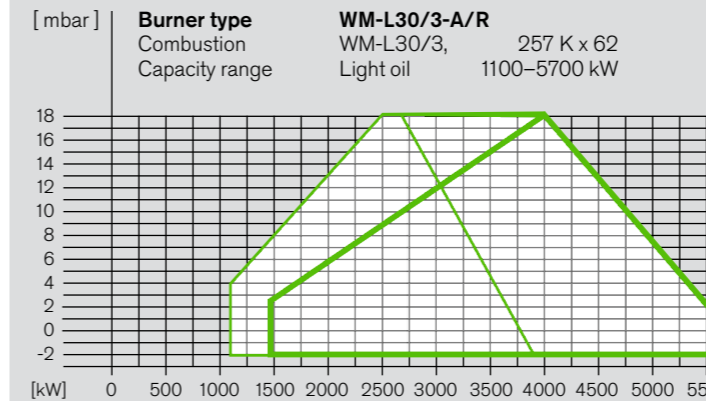
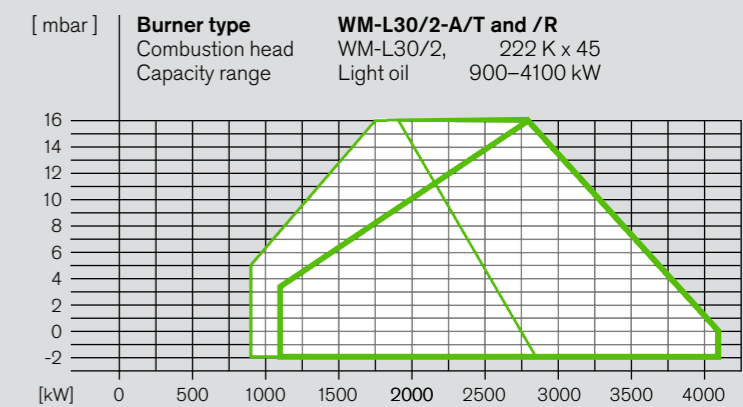
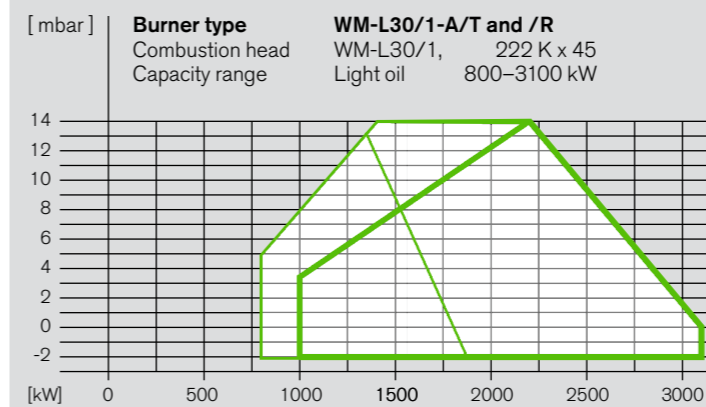

Light oil: Capacity with combustion head
 Closed
 Open

Capacity graphs for oil burners certified in accordance with EN 267.

Stated ratings are based on an air temperature of 20 °C and an installation altitude of 500 m above sea level.

Stated oil throughputs are based on a nett calorific value (LHV) of 11.9 kWh/kg.

DIN CERTCO certification:
 The burners have been type-tested by an independent body (TÜV-Süd) and certified by DIN CERTCO.

Burner selection

WM-G(L)30, versions ZM, ZM-T, and ZM-R

Gas valve train sizing

WM-G(L)30, versions ZM, ZM-T, and ZM-R

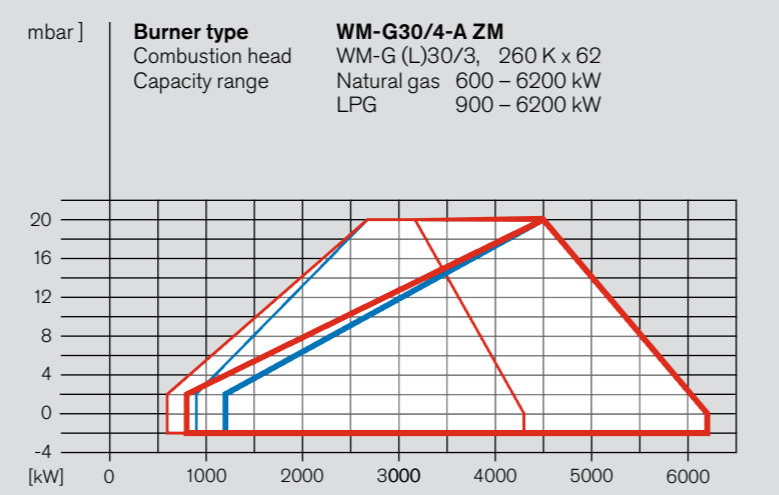
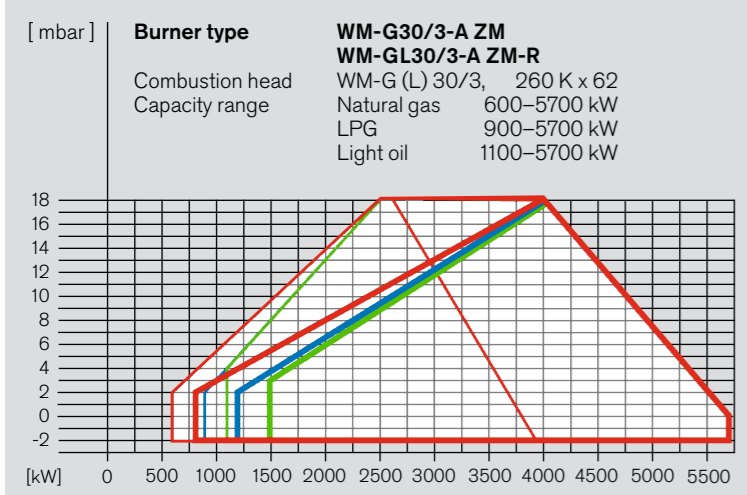
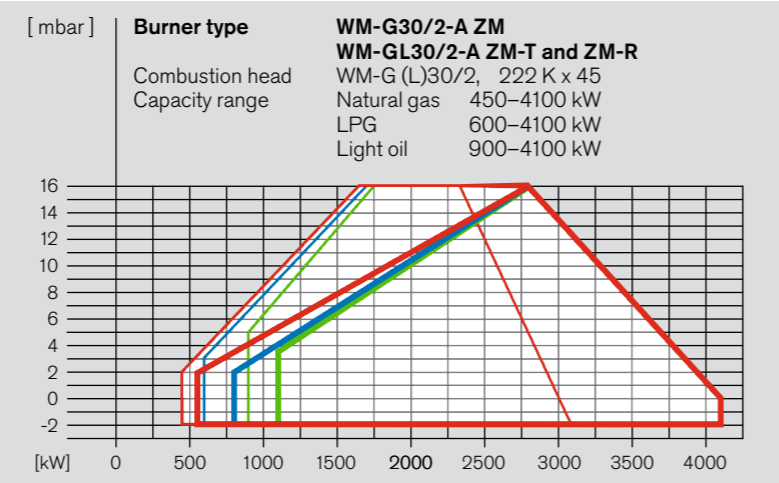
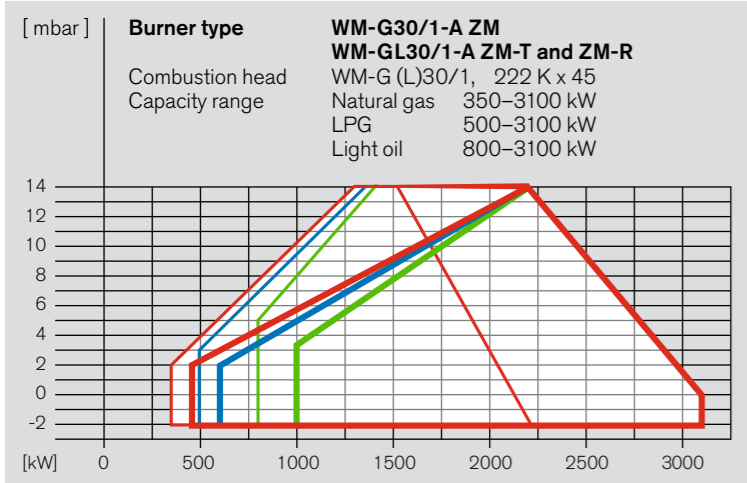

Nat. gas: Capacity with comb. head Closed (red line), Open (red line)
LPG: Capacity with comb. head Closed (blue line), Open (blue line)
Light oil: Capacity with comb. head Closed (green line), Open (green line)

Turndown:
Gas max. 7:1
Light oil max. 3:1

Capacity graphs for gas and dual-fuel burners certified in accordance with EN 676 and EN 267.

Stated ratings are based on an air temperature of 20 °C and an installation at sea level. For installations at higher altitudes, a reduction in capacity of 1 % per 100 m above sea level should be taken into account.

WM-G(L)30/1-A, versions ZM, ZM-T and ZM-R

Burner rating kW	Low-pressure supply (with FRS) (flow pressure in mbar into shutoff valve, P _i ≤ 300 mbar)						High-pressure supply (with HP regulator) (flow pressure in mbar into gas valve assembly)					
	1" 1/2"	2"	65	80	100	125	1" 1/2"	2"	65	80	100	125
	Nominal valve train diameter						Nominal valve train diameter					
	Nominal diameter of gas butterfly						Nominal diameter of gas butterfly					
	80	80	80	80	80	80	80	80	80	80	80	80

Natural gas E LHV = 10.35 kWh/Nm³; d = 0.606

1350	195	72	29	18	14	11	11	55	39	15	10	9	8	8
1550	256	94	37	22	17	14	13	71	51	20	13	11	10	10
1750	-	119	46	27	20	16	15	90	64	24	16	14	12	12
2000	-	153	58	34	24	19	18	117	82	31	20	17	15	14
2250	-	191	70	40	28	22	19	-	102	37	23	19	16	16
2500	-	233	84	47	32	24	22	-	124	43	27	22	18	17
2800	-	290	103	56	37	27	24	-	-	52	31	25	21	20
3100	-	-	123	65	43	31	27	-	-	62	36	28	23	22

Natural gas LL LHV = 8.83 kWh/Nm³; d = 0.641

1350	280	102	39	23	17	13	12	77	54	20	13	11	9	9
1550	-	133	50	29	20	16	15	101	71	26	16	14	12	11
1750	-	168	62	35	25	19	17	128	89	32	20	17	14	13
2000	-	217	79	44	30	23	20	-	116	41	25	20	17	16
2250	-	272	97	53	35	26	23	-	-	49	30	24	20	19
2500	-	-	117	62	41	29	26	-	-	59	35	27	22	21
2800	-	-	144	75	48	34	29	-	-	71	41	32	25	24
3100	-	-	173	89	56	38	33	-	-	85	48	36	29	27

LPG* LHV = 25.89 kWh/Nm³; d = 1.555

1350	84	34	16	11	10	9	8	25	18	9	7	6	6	6
1550	110	43	20	14	12	10	10	33	24	11	9	8	7	7
1750	138	54	24	16	14	12	11	41	30	14	11	9	9	9
2000	179	69	30	20	16	14	13	53	38	17	13	12	11	10
2250	225	85	36	23	18	16	15	65	47	21	15	13	12	12
2500	276	103	42	27	21	17	16	79	57	24	17	15	14	13
2800	-	127	50	31	23	19	18	97	70	28	20	17	15	15
3100	-	153	59	36	26	21	20	118	84	33	22	19	17	16

WM-G(L)30/3-A, versions ZM, ZM-T and ZM-R

Burner rating kW	Low-pressure supply (with FRS) (flow pressure in mbar into shutoff valve, P _i ≤ 300 mbar)						High-pressure supply (with HP regulator) (flow pressure in mbar into gas valve assembly)					
	1 1/2"	2"	65	80	100	125 150	1 1/2"	2"	65	80	100	125 150
	Nominal valve train diameter						Nominal valve train diameter					
	Nominal diameter of gas butterfly						Nominal diameter of gas butterfly					
	80	80	80	80	80	80	80	80	80	80	80	80

Natural gas E LHV = 10.35 kWh/Nm³; d = 0.606

2500	227	78	40	25	18	15	14	118	37	20	15	12	11	11
2900	-	104	53	33	22	19	17	158	49	27	20	16	14	14
3300	-	133	67	41	27	23	21	-	63	34	25	19	18	17
3800	-	174	86	53	34	28	26	-	82	44	32	24	22	21
4300	-	218	106	63	40	32	29	-	102	53	38	28	25	24
4800	-	268	129	75	46	36	32	-	124	63	44	31	28	27
5300	-	-	153	88	52	41	35	-	148	73	51	35	31	29
5700	-	-	175	98	57	44	38	-	169	82	56	38	33	32

Natural gas LL LHV = 8.83 kWh/Nm³; d = 0.641

2500	-	109	54	33	22	18	16	168	51	27	19	14	13	13
2900	-	146	72	43	28	23	21	-	68	36	26	19	17	17
3300	-	187	92	55	35	28	25	-	88	46	33	24	22	21
3800	-	246	119	70	43	35	31	-	115	59	42	30	27	26
4300	-	-	148	85	51	40	35	-	143	72	50	35	31	30
4800	-	-	181	102	60	46	40	-	175	86	59	40	35	33
5300	-	-	216	120	69	52	44	-	-	101	68	45	39	37
5700	-	-	247	136	76	57	48	-	-	114	76	50	43	40

LPG* LHV = 25.89 kWh/Nm³; d = 1.555

2500	97	36	20	14	11	10	9	51	17	11	9	7	7	7
2900	129	47	26	18	14	12	12	68	23	14	11	9	9	9
3300	166	60	33	22	17	15	14	88	30	18	14	12	11	11
3800	219	78	42	28	20	18	17	115	39	23	18	15	14	14
4300	278	97	51	33	24	21	19	146	48	28	22	17	16	16
4800	-	118	61	39	27	23	21	179	57	32	24	19	18	17
5300	-	141	71	44	30	25	23	-	68	37	28	21	19	19
5700	-	161	80	49	32	27	24	-	76	41	30	23	21	20

WM-G(L)30/2-A, versions ZM, ZM-T and ZM-R

Burner rating kW	Low-pressure supply (with FRS) (flow pressure in mbar into shutoff valve, P _i ≤ 300 mbar)						High-pressure supply (with HP regulator) (flow pressure in mbar into gas valve assembly)					
	1" 1/2"	2"	65	80	100	125	1" 1/2"	2"	65	80	100	125
	Nominal valve train diameter						Nominal valve train diameter					
	Nominal diameter of gas butterfly						Nominal diameter of gas butterfly					
	80	80	80	80	80	80	80	80	80	80	80	80

Natural gas E LHV = 10.35 kWh/Nm³; d = 0.606

1700	-	110	42	24	17	14	13	84	59	21	14	11	10	9
2000	-	151	56	32	22	17	16	115	80	29	18	15	13	12
2300	-	198	72	40	28	21	19	-	105	37	23	19	16	15
2600	-	251	90	49	34	25	22	-	134	46	28	23	19	18
3000	-	-	117	63	42	30	27	-	-	60	36	28	23	22
3400	-	-	147	77	50	35	30	-	-	73	42	33	27	25
3800	-	-	180	92	58	40	34	-	-	88	50	38	30	28
4100	-	-	207	105	66	44	37	-	-	101	56	42	33	31

Natural gas LL LHV = 8.83 kWh/Nm³; d = 0.641

1700	-	158	58	32	22	17	15	120	84	29	18	15	12	12
2000	-	216	78	43	29	22	19	-	115	39	24	19	16	15
2300	-	284	101	54	36	26	23	-	-	51	30	24	20	19
2600	-	-	126	67	44	31	27	-	-	63	37	29	24	22
3000	-	-	164	85	55	38	33	-	-	81	47	36	29	27
3400	-	-	207	105	66	45	38	-	-	101	56	43	34	31
3800	-	-	255	128	79	52	44	-	-	123	67	50	39	36
4100	-	-	294	146	89	58	48	-	-	146	76	56	43	39

LPG* LHV = 25.89 kWh/Nm³; d = 1.555

1700	129	50	21	14	12	10	10	37	27	12	9	8	7	7
2000	178	67	28	18	14	12	12	51	37	16	11	10	9	9
2300	233	87	36	23	17	15	14	67	48	20	14	12	11	11
2600	296	110	44	27	21	17	16	84	60	24	17	15	13	13
3000	-	144	56	34	25	20	19	110	79	31	21	18	16	16
3400	-	182	69	41	30	24	22	140	99	38	25	21	19	18
3800	-	225	84	48	34	27	24	-	121	45	29	24	21	20
4100	-	260	96	54	38	29	26	-	140	51	32	27	23	22

WM-G30/4-A, version ZM

Burner rating kW	Low-pressure supply (with FRS) (flow pressure in mbar into shutoff valve, P _i ≤ 300 mbar)						High-pressure supply (with HP regulator) (flow pressure in mbar into gas valve assembly)					
	2"	65	80	100	125 150	2"	65	80	100	125 150		
	Nominal valve train diameter						Nominal valve train diameter					
	Nominal diameter of gas butterfly						Nominal diameter of gas butterfly					
	80	80	80	80	80	80	80	80	80	80		

Natural gas E LHV = 10.35 kWh/Nm³; d = 0.606

2700	90	46	29	20	17	16	43	24	18	14	13	12
3200	125	64	40	27	22	20	60	33	24	19	17	17
3700	165	82	50	33	27	25	78	42	31	23	21	20
4200	209	102	61	39	32	28	98	51	37	27	24	24

Burner selection

WM-G30, version ZM-LN

Gas valve train sizing

WM-G30, version ZM-LN

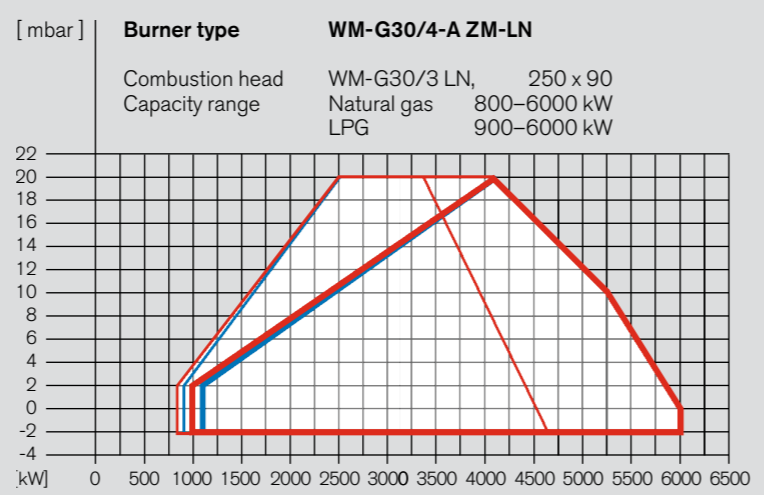
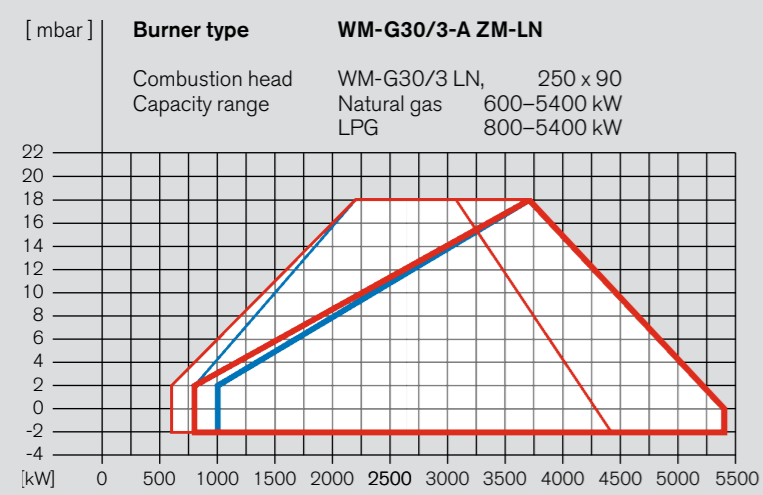
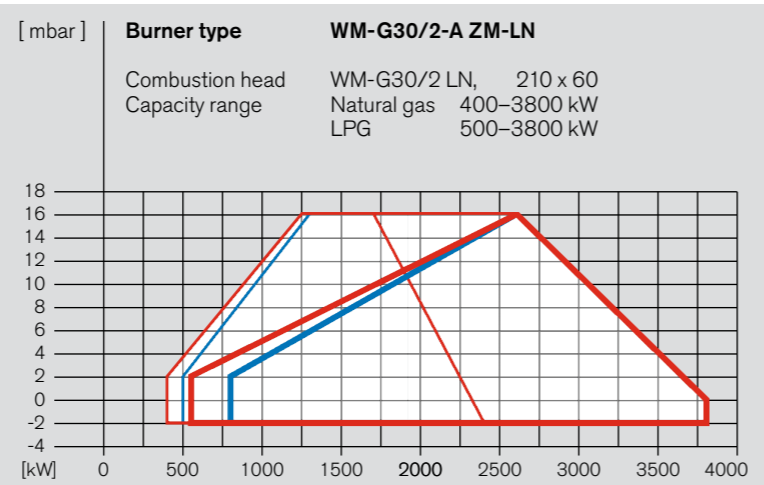
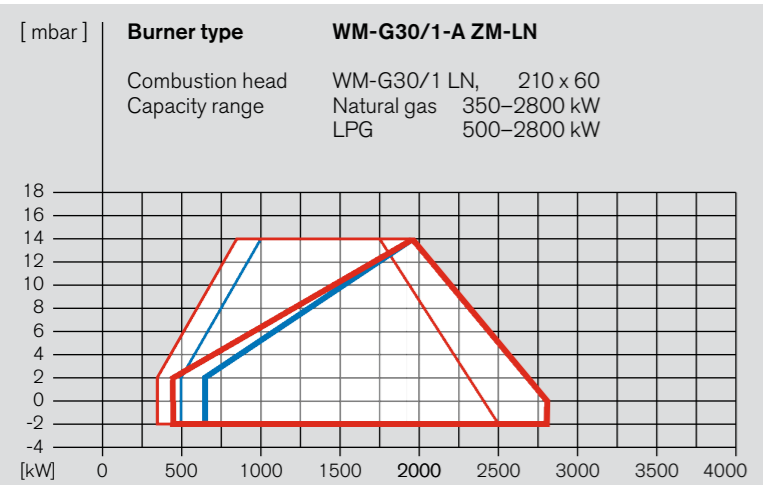

Nat. gas: Capacity with comb. head
Closed (red line), Open (blue line)

LPG: Capacity with comb. head
Closed (red line), Open (blue line)

Turndown:
Gas max. 6:1

Capacity graphs for gas and dual-fuel burners certified in accordance with EN 676 and EN 267.

Stated ratings are based on an air temperature of 20 °C and an installation at sea level. For installations at higher altitudes, a reduction in capacity of 1 % per 100 m above sea level should be taken into account.

WM-G30/1-A, version ZM-LN

Burner rating kW	Low-pressure supply (with FRS) (flow pressure in mbar into shutoff valve, P _i ≤ 300 mbar)					High-pressure supply (with HP regulator) (flow pressure in mbar into gas valve assembly)				
	Nominal valve train diameter					Nominal valve train diameter				
	1" 1/2"	2"	65	80	100 125	1" 1/2"	2"	65	80	100 125
	Nominal diameter of gas butterfly					Nominal diameter of gas butterfly				
	80	80	80	80	80	80	80	80	80	80

Natural gas E LHV = 10.35 kWh/Nm³; d = 0.606

1300	183	70	29	19	15	13	12	53	38	16	12	11	10	9
1500	244	92	39	25	20	17	16	71	51	22	16	15	13	13
1700	-	118	49	32	25	21	20	91	66	29	21	19	17	17
1900	-	147	61	39	31	26	25	114	83	36	27	24	22	21
2100	-	178	73	46	36	30	29	139	100	43	32	28	26	25
2300	-	212	86	54	41	35	33	-	119	51	37	32	29	29
2500	-	248	99	61	46	38	36	-	139	58	41	36	33	32
2800	-	-	118	71	53	43	39	-	-	68	47	40	36	35

Natural gas LL LHV = 8.83 kWh/Nm³; d = 0.641

1300	263	98	39	25	19	16	15	75	54	22	15	13	12	12
1500	-	130	52	32	25	20	19	100	72	29	21	18	16	16
1700	-	166	66	41	31	26	24	128	92	38	27	23	21	20
1900	-	207	82	50	38	31	29	-	115	47	33	29	26	25
2100	-	251	98	59	44	36	34	-	139	56	39	34	30	30
2300	-	-	115	69	51	41	38	-	-	66	45	39	35	34
2500	-	-	133	78	57	46	42	-	-	75	51	43	38	37
2800	-	-	161	92	65	51	46	-	-	88	58	49	42	41

LPG* LHV = 25.89 kWh/Nm³; d = 1.555

1300	80	34	17	13	11	10	10	25	19	10	8	8	7	7
1500	106	44	22	17	15	13	13	34	26	14	12	11	10	10
1700	136	56	28	21	18	17	16	44	34	18	15	14	14	13
1900	169	70	34	25	22	20	19	55	42	23	19	18	17	17
2100	206	84	41	30	26	23	23	66	51	27	22	21	20	20
2300	245	99	47	34	29	26	26	78	60	32	26	24	23	23
2500	287	115	54	38	32	29	28	91	69	36	29	27	25	25
2800	-	140	63	44	36	32	31	110	82	41	32	30	28	27

WM-G30/3-A, version ZM-LN

Burner rating kW	Low-pressure supply (with FRS) (flow pressure in mbar into shutoff valve, P _i ≤ 300 mbar)					High-pressure supply (with HP regulator) (flow pressure in mbar into gas valve assembly)				
	Nominal valve train diameter					Nominal valve train diameter				
	1 1/2"	2"	65	80	100 125 150	1 1/2"	2"	65	80	100 125 150
	Nominal diameter of gas butterfly					Nominal diameter of gas butterfly				
	80	80	80	80	80	80	80	80	80	80

Natural gas E LHV = 10.35 kWh/Nm³; d = 0.606

2600	259	98	57	41	33	30	29	141	54	36	31	27	26	25
3000	-	127	72	51	40	36	34	185	69	45	38	33	31	31
3400	-	159	89	62	47	42	40	-	85	54	45	38	37	36
3800	-	194	107	73	54	49	46	-	103	64	52	44	42	42
4200	-	233	126	84	62	55	52	-	122	75	60	51	48	47
4600	-	275	147	97	70	62	58	-	142	86	69	57	54	53
5000	-	-	169	110	78	68	64	-	164	97	77	63	59	58
5400	-	-	192	124	87	75	70	-	187	109	86	70	65	64

Natural gas LL LHV = 8.83 kWh/Nm³; d = 0.641

2600	-	135	75	52	40	36	34	199	72	46	38	32	31	30
3000	-	175	96	65	49	43	41	-	92	57	47	39	38	37
3400	-	220	118	79	58	51	48	-	114	70	56	47	44	43
3800	-	270	143	94	67	59	55	-	138	83	66	54	51	50
4200	-	-	170	110	77	67	62	-	165	97	76	62	58	56
4600	-	-	199	127	88	75	69	-	193	111	86	69	65	63
5000	-	-	230	144	98	84	77	-	-	127	97	77	72	70
5400	-	-	263	163	110	93	85	-	-	143	109	85	79	77

LPG* LHV = 25.89 kWh/Nm³; d = 1.555

2600	118	52	35	29	25	24	24	68	33	25	23	21	21	21
3000	154	66	44	35	31	29	28	89	41	31	28	26	26	25
3400	195	82	53	42	36	34	33	111	50	38	34	31	30	30
3800	240	99	63	49	42	39	38	136	60	44	39	36	35	35
4200	289	117	73	56	47	44	43	163	70	51	45	41	40	39
4600	-	137	84	64	53	49	48	193	81	58	51	46	45	44
5000	-	158	96	72	59	55	53	-	92	65	57	51	49	49
5400	-	180	108	80	65	60	58	-	104	72	63	56	54	54

WM-G30/2-A, version ZM-LN

Burner rating kW	Low-pressure supply (with FRS) (flow pressure in mbar into shutoff valve, P _i ≤ 300 mbar)					High-pressure supply (with HP regulator) (flow pressure in mbar into gas valve assembly)				
	Nominal valve train diameter					Nominal valve train diameter				
	1" 1/2"	2"	65	80	100 125	1" 1/2"	2"	65	80	100 125
	Nominal diameter of gas butterfly					Nominal diameter of gas butterfly				
	80	80	80	80	80	80	80	80	80	80

Natural gas E LHV = 10.35 kWh/Nm³; d = 0.606

1700	-	120	51	33	27	23	22	93	68	31	23	21	19	19
2000	-	164	69	44	35	30	28	128	93	41	31	28	25	25
2300	-	213	87	55	43	36	34	-	120	52	38	34	31	30
2600	-	-	106	65	49	41	38	-	-	62	44	39	35	34
2900	-	-	127	76	57	46	43	-	-	73	51	44	39	38
3200	-	-	150	88	64	51	47	-	-	85	57	49	43	42
3500	-	-	175	101	72	56	52	-	-	97	64	54	48	46
3800	-	-	201	114	80	62	56	-	-	110	72	60	52	50

Natural gas LL LHV = 8.83 kWh/Nm³; d = 0.641

1700	-	168	68	43	33	27	26	130	94	40	28	25	23	22
2000	-	230	92	56	43	35	33	-	128	53	38	33	30	29
2300	-	-	117	70	52	43	40	-	-	67	47	40	36	35
2600	-	-	144	84	61	49	45	-	-	81	55	47	41	40
2900	-	-	173	99	71	55	50	-	-	96	63	53	47	45
3200	-	-	206	116	81	62	56	-	-	112	72	60	52	50
3500	-	-	241	133	92	69	62	-	-	129	82	67	57	55
3800	-	-	-	152	103	76	68	-	-	92	75	63	60	60

WM-G30/4-A, version ZM-LN

Burner rating kW	Low-pressure supply (with FRS) (flow pressure in mbar into shutoff valve, P _i ≤ 300 mbar)					High-pressure supply (with HP regulator) (flow pressure in mbar into gas valve assembly)				
	Nominal valve train diameter					Nominal valve train diameter				
	2"	65	80	100 125 150	2"	65	80	100 125 150		
	Nominal diameter of gas butterfly					Nominal diameter of gas butterfly				
	80	80	80	80	80	80	80	80		

Natural gas E LHV = 10.35 kWh/Nm³; d = 0.606

3350	154	86	60	46	41	39	83	53	44	38	36	35
3500	168	94	65	49	44	42	90	57	47	40	39	38
4000	215	118	81	60	54	51	114	72	59	50	47	47
4500	267	145	97	72	63	60	140	86	70	59	56	55
5000	-	173	114	83	73	68	168	101	81	67	64	62
5500	-	203	132	93	81	76	197	117	92	76	71	69
6000	-	234	150	104	90	83	-	132	103	83	78	76

Natural gas LL LHV = 8.83 kWh/Nm³; d = 0.641

3350	215	116	78	57	51	48	112	69	55	46	44	43
3500	233	126	84	61	54	51	121	74	60	50	47	46
4000	-	160	105	76	66	62	155	93	74	61	58	57
4500	-	196	127	90	78	73	191	113	89	72	68	66
5000	-	236	151	104	90	83	-	133	104	83	78	76
5500	-	278	175	119	101	93	-	154	119	94	88	85
6000	-	-	200	134	113	103	-	176	134	105	97	94

LPG* LHV = 25.89 kWh/Nm³; d = 1.555

3350	79	51	41	35	33	32	48	36	33	30	29	29
3500	86	55	44	37	35	34	52	39	35	32	31	31
4000	109	69	53	45	43	41	66	48	43	39	38	38
4500	133	83	63	53	49							

Scope of delivery

Description	WM-L30 T	WM-L30 R	WM-G30 ZM / LN	WM-GL30 ZM-T	WM-GL30 ZM-R
Burner housing, hinged flange, housing cover, Weishaupt burner motor, air inlet housing, fan wheel, combustion head, ignition unit, ignition cable, ignition electrodes, combustion manager with control unit, flame sensor, actuators, flange gasket, limit switch on hinged flange, fixing screws	●	●	●	●	●
Digital combustion manager W-FM 50 W-FM 54	● –	● –	● –	– ●	– ●
Valve proving via the combustion manager	–	–	●	●	●
Class-A double gas valve assembly	–	–	●	●	●
Gas butterfly valve	–	–	●	●	●
Air pressure switch	○	○	●	●	●
Low gas pressure switch	–	–	●	●	●
Preset, capacity-based mixing assembly	●	●	●	●	●
Actuators for compound regulation of fuel and air via W-FM: Air damper actuator Gas butterfly valve actuator Oil regulator actuator	● – –	● – ●	● ● –	● ● –	● ● ●
Oil pressure switch in return	–	●	–	–	●
Oil pump fitted to burner	●	●	–	●	●
Oil hoses	●	●	–	●	●
2 oil solenoid valves, oil regulator, nozzle head with solenoid valve, preinstalled regulating nozzle and safety shutoff device	–	●	–	–	●
3 oil solenoid valves, three-stage nozzle head with preinstalled oil nozzles, 1 additional oil safety solenoid valve	●	–	–	●	–
Electromagnetic clutch	○	○	–	●	●
Star-delta combination fitted to motor	●	●	●	●	●
IP 54 protection	●	●	●	●	●

EN 676 stipulates that ball valves, gas filters, and gas pressure regulators form part of the burner supply (see Weishaupt accessories list). Please enquire or see the special equipment section of this brochure for further burner executions.

- Standard
- Optional

Order numbers

Oil burners, version T

Burner type	Version	Order No.
WM-L30/1-A	T	211 320 10
WM-L30/2-A	T	211 320 20

DIN CERTCO: 5G1046

Oil burners, version R

Burner type	Version	Order No.
WM-L30/1-A	R	215 320 10
WM-L30/2-A	R	215 320 20
WM-L30/3-A	R	215 320 30

DIN CERTCO: 5G1046

Gas burners, version ZM

Burner type	Version	Valve train size	Order No.
WM-G30/1-A	ZM	R 1	217 310 11
		R 1½	217 310 12
		R 2	217 310 13
		DN 65	217 310 14
		DN 80	217 310 15
		DN 100	217 310 16
WM-G30/2-A	ZM	R 1	217 312 11
		R 1½	217 312 12
		R 2	217 312 13
		DN 65	217 312 14
		DN 80	217 312 15
		DN 100	217 312 16
WM-G30/3-A	ZM	R 1½	217 314 12
		R 2	217 314 13
		DN 65	217 314 14
		DN 80	217 314 15
		DN 100	217 314 16
		DN 125	217 314 17
WM-G30/4-A	ZM	R 2	217 316 13
		DN 65	217 316 14
		DN 80	217 316 15
		DN 100	217 316 16
		DN 125	217 316 17
		DN 150	217 316 18

CE-PIN: CE-0085 BU 0359

Dual-fuel burners, version ZM-T

Burner type	Version	Valve train size	Order No.
WM-GL30/1-A	ZM-T	R 1	218 310 11
		R 1½	218 310 12
		R 2	218 310 13
		DN 65	218 310 14
		DN 80	218 310 15
		DN 100	218 310 16
WM-GL30/2-A	ZM-T	R 1	218 311 11
		R 1½	218 311 12
		R 2	218 311 13
		DN 65	218 311 14
		DN 80	218 311 15
		DN 100	218 311 16
		DN 125	218 311 17

DIN CERTCO: 5G1044M

CE-PIN: CE-0085 BU 0360

Dual-fuel burners, version ZM-R

Burner type	Version	Valve train size	Order No.
WM-GL30/1-A	ZM-R	R 1	218 315 11
		R 1½	218 315 12
		R 2	218 315 13
		DN 65	218 315 14
		DN 80	218 315 15
		DN 100	218 315 16
WM-GL30/2-A	ZM-R	R 1	218 316 11
		R 1½	218 316 12
		R 2	218 316 13
		DN 65	218 316 14
		DN 80	218 316 15
		DN 100	218 316 16
WM-GL30/3-A	ZM-R	R 1½	218 317 12
		R 2	218 317 13
		DN 65	218 317 14
		DN 80	218 317 15
		DN 100	218 317 16
		DN 125	218 317 17
		DN 150	218 317 18

DIN CERTCO: 5G1044M

CE-PIN: CE-0085 BU 0360

Order numbers

Special equipment WM-L30, version T

Gas burners, version ZM-LN

Burner type	Version	Valve train size	Order No.
WM-G30/1-A	ZM-LN	R 1	217 311 11
		R 1½	217 311 12
		R 2	217 311 13
		DN 65	217 311 14
		DN 80	217 311 15
		DN 100	217 311 16
		DN 125	217 311 17
WM-G30/2-A	ZM-LN	R 1	217 313 11
		R 1½	217 313 12
		R 2	217 313 13
		DN 65	217 313 14
		DN 80	217 313 15
		DN 100	217 313 16
		DN 125	217 313 17
WM-G30/3-A	ZM-LN	R 1½	217 315 12
		R 2	217 315 13
		DN 65	217 315 14
		DN 80	217 315 15
		DN 100	217 315 16
		DN 125	217 315 17
		DN 150	217 315 18
WM-G30/4-A	ZM-LN	R 2	217 321 13
		DN 65	217 321 14
		DN 80	217 321 15
		DN 100	217 321 16
		DN 125	217 321 17
		DN 150	217 321 18

CE-PIN: CE-0085 BU 0359

Version T (three-stage)	WM-L30/1-A T	WM-L30/2-A T
Pressure gauge with ball valve	110 000 79	110 002 82
Vacuum gauge with ball valve	110 005 69	110 017 00
Combustion head extension	by 150 mm	210 031 03
	by 300 mm	210 031 04
Oil hoses, 1300 mm in lieu of 1000 mm	110 000 72	110 000 72
Two-stage operation with low-impact start or changeover	210 030 31	210 030 31
Air inlet flange for ducted-air connection, with LGW air pressure switch (LGW 50 also required)	210 031 15	210 031 15
LGW 50 air pressure switch ¹⁾	210 030 08	210 030 08
Oil meter	VZO20 without transmitter	210 031 14
	VZO20 with low-frequency transmitter for external wiring	210 031 13
	VZO20 with low-frequency transmitter for internal wiring	210 031 24
ST 18/7 and ST 18/4 plug connections	210 030 13	210 030 13
Burner-mounted KS20 controller (W-FM 50)	250 033 15	250 033 15
W-FM 100 (suitable for continuous firing) in lieu of W-FM 50 ¹⁾	burner-mounted	210 030 32
	supplied loose	210 030 88
Integral load controller and analogue signal convertor for W-FM 100	110 017 18	110 017 18
W-FM 200 in lieu of W-FM 50, with integral load controller, analogue signal convertor, and VSD module, with optional fuel metering	burner-mounted	210 030 10
	supplied loose	210 031 54
DSB158 minimum pressure switch in supply (W-FM 100 / 200) ¹⁾	210 030 46	210 030 46
QRI flame sensor in lieu of QRB ¹⁾	210 030 24	210 030 24
ABE with Chinese-character display, supplied loose (W-FM 100 / 200)	110 018 53	110 018 53
Special voltage (on application only)	Please enquire	Please enquire
110 V control voltage	250 031 72	250 031 72

Country-specific executions and special voltages on application

¹⁾ Required for PED (2014/68/EU) compliance.

Special equipment WM-L30, version R

Version R (sliding-two-stage or modulating)	WM-L30/1-A R	WM-L30/2-A R	WM-L30/3-A R
Pressure gauge with ball valve on pump	110 002 82	110 002 82	110 002 82
Pressure gauge with ball valve in return	110 011 50	110 011 50	110 011 50
Vacuum meter with ball valve	110 017 00	110 017 00	110 017 00
Combustion head extension	by 150 mm	210 031 05	210 031 05
	by 300 mm	210 031 07	210 031 07
Oil hoses, 1300 mm in lieu of 1000 mm	110 001 59	–	–
Air inlet flange for ducted-air connection, with LGW air pressure switch (LGW 50 also required)	210 031 15	210 031 15	210 031 15
LGW 50 air pressure switch ¹⁾	210 031 39	210 031 39	210 031 39
ST 18/7 and ST 18/4 plug connections	250 030 22	250 030 22	250 030 22
Burner-mounted KS20 controller (W-FM 50)	250 033 15	250 033 15	250 033 15
W-FM 100 (suitable for continuous firing) in lieu of W-FM 50 ¹⁾	burner-mounted	210 030 38	210 030 38
	supplied loose	210 031 47	210 031 47
Integral load controller and analogue signal convertor for W-FM 100	110 017 18	110 017 18	110 017 18
W-FM 200 in lieu of W-FM 50, with integral load controller, analogue signal convertor, and VSD module, with optional fuel metering	burner-mounted	210 030 39	210 030 39
	supplied loose	on application	on application
DSB158 minimum pressure switch in supply (W-FM 100 / 200) ¹⁾	210 031 09	210 031 09	210 031 09
QRI flame sensor in lieu of QRB ¹⁾	210 030 24	210 030 24	210 030 24
VSD with integral frequency convertor (W-FM 50 / 200 required)	210 030 97	210 031 48	210 031 49
VSD with separate frequency convertor (W-FM 200 required) (See accessories list for frequency convertor)	210 030 98	210 030 98	210 031 00
W-FM 200 with extended O ₂ trim / CO control functionality	on application	on application	on application
ABE with Chinese-character display, supplied loose (W-FM 100 / 200)	110 018 53	110 018 53	110 018 53
Special voltage (on application only)	on application	on application	on application
110 V control voltage	250 031 72	250 031 72	250 031 72

Country-specific executions and special voltages on application

¹⁾ Required for PED (2014/68/EU) compliance.

Special equipment WM-G30, version ZM

Version ZM	WM-G30/1-A	WM-G30/2-A	WM-G30/3-A	WM-G30/4-A
Combustion head extension	by 150 mm	250 031 83	250 031 83	250 031 85
	by 300 mm	250 031 84	250 031 84	250 031 86
Solenoid valve for air pressure switch test with continuous-run fan or post-purge	250 030 21	250 030 21	250 030 21	250 030 21
High gas pressure switch ¹⁾ (Screwed W-MF / DMV for low-pressure supplies)	GW 50 A6/1	250 033 30	250 033 30	250 033 30
	GW 150 A6/1	250 033 31	250 033 31	250 033 31
	GW 500 A6/1	250 033 32	250 033 32	250 033 32
High gas pressure switch ¹⁾ (Flanged DMV / VGD for low-pressure supplies)	GW 50 A6/1	150 017 49	150 017 49	150 017 49
	GW 150 A6/1	150 017 50	150 017 50	150 017 50
	GW 500 A6/1	150 017 51	150 017 51	150 017 51
High gas pressure switch ¹⁾ (Fitted to high-pressure regulator)	GW 50 A6/1	250 033 33	250 033 33	250 033 33
	GW 150 A6/1	250 033 34	250 033 34	250 033 34
	GW 500 A6/1	250 033 35	250 033 35	250 033 35
ST 18/7 and ST 18/4 plug connections (W-FM 50 / 100 / 200)	250 030 22	250 030 22	250 030 22	250 030 22
Air inlet flange for ducted-air connection, with LGW air pressure switch	210 031 15	210 031 15	210 031 15	–
Motor with 230 V contactor and overload protection	250 032 61	250 033 29	250 033 29	250 033 29
Burner-mounted KS20 controller (W-FM 50)	250 033 15	250 033 15	250 033 15	250 033 15
W-FM 100 (suitable for continuous firing) in lieu of W-FM 50 ¹⁾	burner-mounted	250 030 74	250 030 74	250 030 74
	supplied loose	250 032 32	250 032 32	250 032 32
Integral load controller & analogue signal convertor for W-FM 100	110 017 18	110 017 18	110 017 18	110 017 18
W-FM 200 in lieu of W-FM 50 with integral load controller, analogue signal convertor, and VSD module, with optional fuel metering	burner-mounted	250 030 75	250 030 75	250 030 75
	supplied loose	250 032 63	250 032 63	250 032 63
VSD with integral frequency convertor (W-FM 50 / 200 required)	210 030 97	210 030 97	210 031 49	auf Anfrage
VSD with separate frequency convertor (W-FM 200 required) (See accessories list for frequency convertor)	210 030 98	210 030 98	210 030 98	auf Anfrage
W-FM 200 with extended O ₂ trim / CO control functionality	250 033 78	250 033 78	250 033 78	250 033 78
Offset gas butterfly valve and DMV for vertical firing	250 032 93	250 032 93	250 032 93	250 032 93
ABE with Chinese-character display, supplied loose (W-FM 100 / 200)	110 018 53	110 018 53	110 018 53	110 018 53
110 V control voltage	250 031 72	250 031 72	250 031 72	auf Anfrage

Country-specific executions and special voltages on application

¹⁾ Required for PED (2014/68/EU) compliance.

Special equipment WM-GL30, version ZM-T

Special equipment WM-GL30, version ZM-R

Version ZM-T		WM-GL30/1-A	WM-GL30/2-A
Combustion head extension	by 150 mm	250 031 87	250 031 87
	by 300 mm	250 031 88	250 031 88
Solenoid valve for air pressure switch test with continuous-run fan or post-purge		250 030 21	250 030 21
High gas pressure switch ¹⁾ (Screwed W-MF / DMV for low-pressure supplies)	GW 50 A6/1	250 033 30	250 033 30
	GW 150 A6/1	250 033 31	250 033 31
	GW 500 A6/1	250 033 32	250 033 32
High gas pressure switch ¹⁾ (Flanged DMV / VGD for low-pressure supplies)	GW 50 A6/1	150 017 49	150 017 49
	GW 150 A6/1	150 017 50	150 017 50
	GW 500 A6/1	150 017 51	150 017 51
High gas pressure switch ¹⁾ (Fitted to high-pressure regulator)	GW 50 A6/1	250 033 33	250 033 33
	GW 150 A6/1	250 033 34	250 033 34
	GW 500 A6/1	250 033 35	250 033 35
ST 18/7 and ST 18/4 plug connections (W-FM 54)		250 031 99	250 031 99
ST 18/7 plug connection (W-FM 100 / 200)		250 032 01	250 032 01
Air inlet flange for ducted-air connection, with LGW air pressure switch		210 031 15	210 031 15
DSB158 minimum pressure switch in supply ¹⁾		210 030 46	210 030 46
W-FM 100 (suitable for continuous firing) in lieu of W-FM 54 ¹⁾ with integral load controller and analogue signal convertor	burner-mounted	250 031 78	250 031 78
	supplied loose	250 033 07	250 033 07
W-FM 200 in lieu of W-FM 54 with integral load controller, analogue signal convertor and VSD module, with optional fuel metering	burner-mounted	250 031 77	250 031 77
	supplied loose	250 033 08	250 033 08
VSD with integral frequency convertor (W-FM 54 / 200 required)		210 030 97	210 031 48
VSD with separate frequency convertor (W-FM 200 required) (See accessories list for frequency convertor)		210 030 98	210 030 98
Oil hoses, 1300 mm in lieu of 1000 mm		150 000 47	150 000 44
VZO20 oil meter without transmitter		250 032 27	250 032 27
VZO20 oil meter with low-frequency transmitter for internal wiring (W-FM 50 / 54 / 200)		210 031 24	210 031 24
VZO20 oil meter with low-frequency transmitter for external wiring		250 032 28	250 032 28
Offset gas butterfly valve and gas valve assembly for vertical firing		250 032 96	250 032 96
ABE with Chinese-character display, supplied loose (W-FM 100 / 200)		110 018 53	110 018 53
110 V control voltage (W-FM 100 / 200) (W-FM 54)		250 031 72	250 031 72
		Please enquire	Please enquire

Country-specific executions and special voltages on application

¹⁾ Required for PED (2014/68/EU) compliance.

Version ZM-R		WM-GL30/1-A	WM-GL30/2-A	WM-GL30/3-A
Combustion head extension	by 150 mm	250 031 89	250 031 89	250 031 91
	by 300 mm	250 031 90	250 031 90	250 031 92
Solenoid valve for air pressure switch test with continuous-run fan or post-purge		250 030 21	250 030 21	250 030 21
High gas pressure switch ²⁾ (Screwed W-MF / DMV for low-pressure supplies)	GW 50 A6/1	250 033 30	250 033 30	250 033 30
	GW 150 A6/1	250 033 31	250 033 31	250 033 31
	GW 500 A6/1	250 033 32	250 033 32	250 033 32
High gas pressure switch ²⁾ (Flanged DMV / VGD for low-pressure supplies)	GW 50 A6/1	150 017 49	150 017 49	150 017 49
	GW 150 A6/1	150 017 50	150 017 50	150 017 50
	GW 500 A6/1	150 017 51	150 017 51	150 017 51
High gas pressure switch ²⁾ (Fitted to high-pressure regulator)	GW 50 A6/1	250 033 33	250 033 33	250 033 33
	GW 150 A6/1	250 033 34	250 033 34	250 033 34
	GW 500 A6/1	250 033 35	250 033 35	250 033 35
ST 18/7 and ST 18/4 plug connections (W-FM 54 / 100 / 200)		250 030 22	250 030 22	250 030 22
Air inlet flange for ducted-air connection, with LGW air pressure switch		Please enquire	Please enquire	Please enquire
DSB158 minimum pressure switch in supply ²⁾		210 031 09	210 031 09	210 031 09
W-FM 100 (suitable for continuous firing) in lieu of W-FM 54 ²⁾	burner-mounted	250 031 76	250 031 76	250 031 76
	supplied loose	250 032 74	250 032 74	250 032 74
Integral load controller and analogue signal convertor for W-FM 100		110 017 18	110 017 18	110 017 18
W-FM 200 in lieu of W-FM 54 with integral load controller, analogue signal convertor and VSD module, with optional fuel metering	burner-mounted	250 031 77	250 031 77	250 031 77
	supplied loose	250 032 75	250 032 75	250 032 75
VSD with integral frequency convertor (W-FM 54 / 200 required) ¹⁾		210 030 97	210 031 48	210 031 49
VSD with separate frequency convertor (W-FM 200 required) (See accessories list for frequency convertor) ¹⁾		210 030 98	210 030 98	210 031 00
W-FM 200 with extended O ₂ trim / CO control functionality		250 033 78	250 033 78	250 033 78
Oil hoses, 1300 mm in lieu of 1000 mm		Please enquire	–	–
Offset gas butterfly valve and gas valve assembly for vertical firing		250 032 93	250 032 93	250 032 93
ABE with Chinese-character display, supplied loose (W-FM 100 / 200)		110 018 53	110 018 53	110 018 53
110 V control voltage (W-FM 100 / 200) (W-FM 54)		250 031 72	250 031 72	250 031 72
		Please enquire	Please enquire	Please enquire

Country-specific executions and special voltages on application

¹⁾ VSD with ZM-R version burners: General conditions for modulating capacity regulation when firing on oil
– Frequency: min. 35 Hz
– Turndown: max. 3:1

²⁾ Required for PED (2014/68/EU) compliance.

Special equipment WM-G30, version ZM-LN

Technical data Oil burners

Version ZM-LN		WM-G30/1-A	WM-G30/2-A	WM-G30/3-A	WM-G30/4-A
Combustion head extension	by 150 mm	250 032 39	250 032 39	250 032 41	250 032 41
	by 300 mm	250 032 40	250 032 40	250 032 42	250 032 42
Solenoid valve for air pressure switch test with continuous-run fan or post-purge		250 030 21	250 030 21	250 030 21	250 030 21
High gas pressure switch ¹⁾	GW 50 A6/1	250 033 30	250 033 30	250 033 30	250 033 30
(Screwed W-MF / DMV for low-pressure supplies)	GW 150 A6/1	250 033 31	250 033 31	250 033 31	250 033 31
	GW 500 A6/1	250 033 32	250 033 32	250 033 32	250 033 32
High gas pressure switch ¹⁾	GW 50 A6/1	150 017 49	150 017 49	150 017 49	150 017 49
(Flanged DMV / VGD for low-pressure supplies)	GW 150 A6/1	150 017 50	150 017 50	150 017 50	150 017 50
	GW 500 A6/1	150 017 51	150 017 51	150 017 51	150 017 51
High gas pressure switch ¹⁾	GW 50 A6/1	250 033 33	250 033 33	250 033 33	250 033 33
(Fitted to high-pressure regulator)	GW 150 A6/1	250 033 34	250 033 34	250 033 34	250 033 34
	GW 500 A6/1	250 033 35	250 033 35	250 033 35	250 033 35
ST 18/7 and ST 18/4 plug connections (W-FM 50 / 100 / 200)		250 030 22	250 030 22	250 030 22	250 030 22
Air inlet flange for ducted-air connection, with LGW air pressure switch		210 031 15	210 031 15	210 031 15	210 031 15
Motor with 230 V contactor and overload protection		250 032 61	250 033 29	250 033 29	250 033 29
Burner-mounted KS20 controller (W-FM 50)		250 033 15	250 033 15	250 033 15	250 033 15
W-FM 100 (suitable for continuous firing) in lieu of W-FM 50 ¹⁾	burner-mounted	250 030 74	250 030 74	250 030 74	250 030 74
	supplied loose	250 032 32	250 032 32	250 032 32	250 032 32
Integral load controller & analogue signal convertor for W-FM 100		110 017 18	110 017 18	110 017 18	110 017 18
W-FM 200 in lieu of W-FM 50 with integral load controller, analogue signal convertor, and VSD module, with optional fuel metering	burner-mounted	250 030 75	250 030 75	250 030 75	250 030 75
	supplied loose	250 032 63	250 032 63	250 032 63	250 032 63
VSD with integral frequency convertor (W-FM 50 / 200 required)		210 030 97	210 030 97	210 031 49	210 031 49
VSD with separate frequency convertor (W-FM 200 required) (See accessories list for frequency convertor)		210 030 98	210 030 98	210 031 00	210 031 00
W-FM 200 with extended O ₂ trim / CO control functionality		250 033 78	250 033 78	250 033 78	250 033 78
Offset gas butterfly valve and gas valve assembly for vertical firing			250 032 93	250 032 93	250 032 93
ABE with Chinese-character display, supplied loose (W-FM 100 / 200)		110 018 53	110 018 53	110 018 53	110 018 53
110 V control voltage		250 031 72	250 031 72	250 031 72	250 031 72
Flue gas recirculation (must be sized by factory)		250 034 67	250 034 67	250 034 67	250 034 67

Country-specific executions and special voltages on application

¹⁾ Required for PED (2014/68/EU) compliance.

Oil burners, version T		WM-L30/1-A	WM-L30/2-A
Burner motor	Weishaupt type	WM-D 132/170-2/7K5	WM-D 132/210-2/10K0
Motor power output	kW	7.5	10
Nominal current	A	15	22
Motor protection switch ¹⁾ or motor prefusing ¹⁾	type (e.g.) A minimum	PKE32/XTU-32 25 A gG / T (by others)	PKE32/XTU-32 35 A gG / T (by others)
Speed (50 Hz)	rpm	2940	2940
Combustion manager	type	W-FM 50	W-FM 50
Flame monitoring	type	QRB	QRB
Air damper actuator	type	STE50	STE50
NO _x Class per EN 267		2	2
Mass	kg	approx. 150	approx. 155
Integral pump max. flow rate	type l/h	J7 392	TA2 525
Oil hoses	DN / length	13 / 1000	20 / 1000

Oil burners, version R		WM-L30/1-A	WM-L30/2-A	WM-L30/3-A
Burner motor	Weishaupt type	WM-D 132/170-2/7K5	WM-D 132/210-2/10K0	WM-D 132/210-2/14K0
Motor power output	kW	7.5	10	14
Nominal current	A	15	22	28
Motor protection switch ¹⁾ or motor prefusing ¹⁾	type (e.g.) A minimum	PKE32/XTU-32 25 A gG / T (by others)	PKE32/XTU-32 35 A gG / T (by others)	PKE32/XTU-32 50 A gG / T (by others)
Speed (50 Hz)	rpm	2940	2940	2920
Combustion manager	type	W-FM 50	W-FM 50	W-FM 50
Flame monitoring	type	QRB	QRB	QRB
Air damper / oil actuator	Type	STE50	STE50	STE50
NO _x Class per EN 267		2	2	2
Mass	kg	approx. 160	approx. 165	approx. 175
Integral pump max. flow rate	type l/h	TA3 785	TA4 1050	TA5 1410
Oil hoses	DN / length	20 / 1000	25 / 1300	25 / 1300

¹⁾ The necessary motor protection can be provided either by a motor protection switch (supplied and fitted into a panel by others), or with integral motor overload protection (see special equipment).

Voltages and frequencies:

The burners are equipped as standard for three-phase alternating current, 400 V, 3 ~, 50 Hz. Other voltages and frequencies are available on application.

Standard burner motor:

Insulation Class F, IP 55 protection.
IE3 Premium Efficiency.

Technical data

Gas and dual-fuel burners

Gas burners		WM-G30/1-A	WM-G30/2-A	WM-G30/3-A	WM-G30/4-A ZM	WM-G30/4-A ZM-LN
Burner motor	Weishaupt type	WM-D 132/170-2/7K5	WM-D 132/210-2/10K0	WM-D 132/210-2/14K0	WM-D 132/210-2/15K5	WM-D 132/210-2/14K0
Motor power output	kW	7.5	10	14	15,5	14
Nominal current	A	15	22	28	32	28
Motor protection switch ¹⁾ or motor prefusing ¹⁾	type (e.g.) A minimum	PKE32/XTU-32 25 A gG / T (by others)	PKE32/XTU-32 35 A gG / T (by others)	PKE32/XTU-32 50 A gG / T (by others)	PKE65/XTU-65 50 A gG / T (by others)	PKE32/XTU-32 50 A gG / T (by others)
Speed (50 Hz)	rpm	2940	2940	2920	2900	2920
Combustion manager	type	W-FM 50	W-FM 50	W-FM 50	W-FM 50	W-FM 50
Flame monitoring	type	ION	ION	ION	ION	ION
Air damper / gas actuator	type	STE50	STE50	STE50	STE50	STE50
NOx Class per EN 676	ZM / ZM-LN	2 / 3	2 / 3	2 / 3	2	3
Mass (excluding gas train)	kg	approx. 159	approx. 164	approx. 179	approx. 179	approx. 179

Dual-fuel burners, version ZM-T		WM-GL30/1-A	WM-GL30/2-A
Burner motor	Weishaupt type	WM-D 132/170-2/7K5	WM-D 132/210-2/10K0
Motor power output	kW	7.5	10
Nominal current	A	15	22
Motor protection switch ¹⁾ or motor prefusing ¹⁾	type (e.g.) A minimum	PKE32/XTU-32 25 A gG / T (by others)	PKE32/XTU-32 35 A gG / T (by others)
Speed (50 Hz)	rpm	2940	2940
Combustion manager	type	W-FM 54	W-FM 54
Flame monitoring	type	QRA2	QRA2
Air damper / gas / oil actuator	type	STE50	STE50
NOx Class per EN 676 / EN 267		2	2
Mass (excluding gas train)	kg	approx. 174	approx. 179
Integral pump	type	J7	TA2
max. flow rate	l/h	392	525
Oil hoses	DN / length	13 / 1000	20 / 1000

Dual-fuel burners, version ZM-R		WM-GL30/1-A	WM-GL30/2-A	WM-GL30/3-A
Burner motor	Weishaupt type	WM-D 132/170-2/7K5	WM-D 132/210-2/10K0	WM-D 132/210-2/14K0
Motor power output	kW	7.5	10	14
Nominal current	A	15	22	28
Motor protection switch ¹⁾ or motor prefusing ¹⁾	type (e.g.) A minimum	PKE32/XTU-32 25 A gG / T (by others)	PKE32/XTU-32 35 A gG / T (by others)	PKE32/XTU-32 50 A gG / T (by others)
Speed (50 Hz)	rpm	2940	2940	2920
Combustion manager	type	W-FM 54	W-FM 54	W-FM 54
Flame monitoring	type	QRA2	QRA2	QRA2
Air damper / gas / oil actuator	type	STE50	STE50	STE50
NOx Class per EN 676 / EN 267		2	2	2
Mass (excluding gas train)	kg	approx. 187	approx. 192	approx. 202
Integral pump	type	TA3	TA4	TA5
max. flow rate	l/h	785	1050	1410
Oil hoses	DN / length	20 / 1000	25 / 1300	25 / 1300

¹⁾ The necessary motor protection can be provided either by a motor protection switch (supplied and fitted into a panel by others), or with integral motor overload protection (see special equipment).

Voltages and frequencies:
The burners are equipped as standard for three-phase alternating current, 400 V, 3 ~, 50 Hz. Other voltages and frequencies are available on application.

Standard burner motor:
Insulation Class F, IP 55 protection. IE3 Premium Efficiency.

Fuel systems

Gas-side fuel system

W-FM 50 / 100 / 200

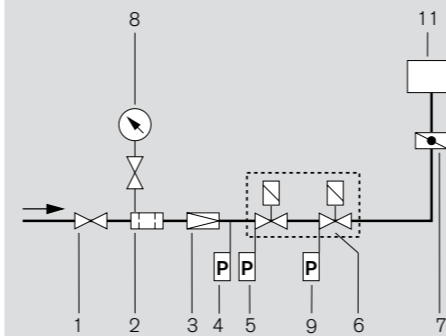

- 1 Ball valve *
- 2 Gas filter *
- 3 Pressure regulator, (LP) or (HP) *
- 4 High gas pressure switch *
- 5 Low gas pressure switch
- 6 Double gas valve assembly
- 7 Gas butterfly valve
- 8 Pressure gauge with push-button valve *
- 9 Valve-proving pressure switch
- 10 Low gas / valve-proving pressure switch
- 11 Burner

Layout of the valve train

On boilers with hinged doors, the valve train must be mounted on the opposite side to the boiler-door hinges.

Compensator

To enable a tension free mounting of the valve train, the fitting of a compensator is strongly recommended.

Break points in the valve train

Break points in the valve train should be provided to enable the door of the heat generator to be swung open. The main gas line is best separated at the compensator.

W-FM 54

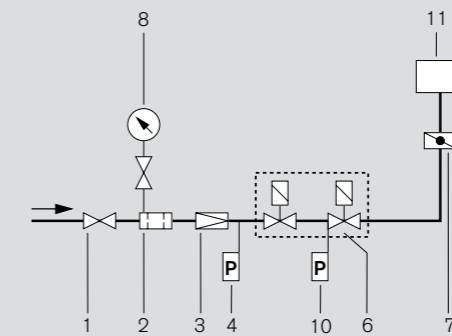

* Not included in burner price

Mounting position of the high gas pressure switch:
On the regulator outlet of HP trains
After the regulator of screwed LP trains
On the valve assembly inlet of flanged LP trains
Cable length approx. 2.5 m.

Support of the valve train

The valve train should be properly supported in accordance with the site conditions. See the Weishaupt accessories list for various valve train support components.

Gas meter

A gas meter must be installed to measure gas consumption during commissioning and servicing.

Optional thermal shutoff (when required by local regulations)

Integrated into the ball valve of screwed valve trains. A separate component with HTB seals fitted before the ball valve on flanged valve trains.

Oil-side fuel system

Version (ZM-)T

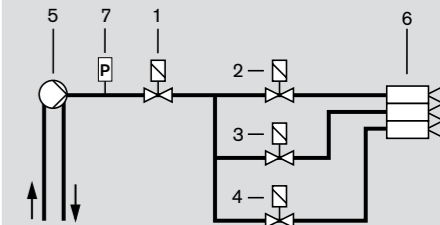

- 1 Strainer
- 2 Normally closed solenoid valve in supply
- 3 Normally closed solenoid valve in return
- 4 Nozzle head with regulating nozzle
- 5 Burner-mounted oil pump
- 6 Oil regulator
- 7 Pressure switch in return
- 8 Pressure switch in supply (optional)

Version (ZM-)R

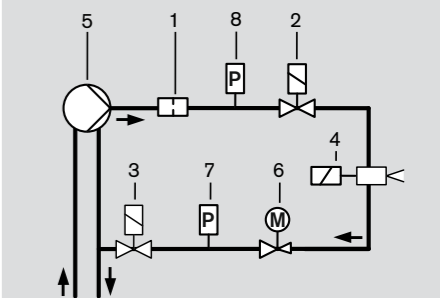

- 1 Strainer
- 2 Normally closed solenoid valve in supply
- 3 Normally closed solenoid valve in return
- 4 Nozzle head with regulating nozzle
- 5 Burner-mounted oil pump
- 6 Oil regulator
- 7 Pressure switch in return
- 8 Pressure switch in supply (optional)

Dimensions

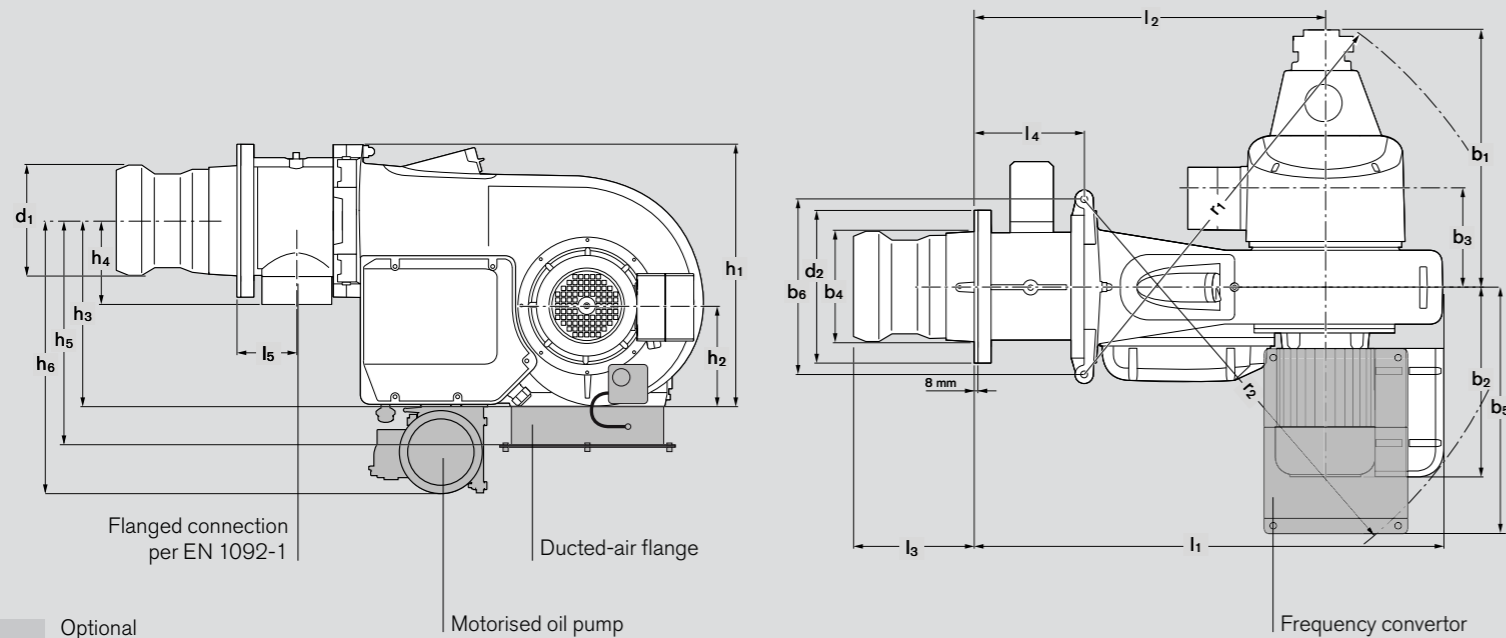

Burner type	Dimensions in mm												
	l ₁	l ₂	l ₃	l ₄	l ₅	b ₁	b ₂	b ₃	b ₄	b ₅ **	b ₆	r ₁	r ₂ *
WM-L30/1-A T	941	622	301-326	43	-	481	508	261	301	570	440	992	1111
WM-L30/2-A T	941	622	301-326	43	-	480	548	261	301	670	440	992	1137
WM-L30/1-A R	941	622	301-326	43	-	484	508	261	301	570	440	992	1111
WM-L30/2-A R	941	622	301-326	43	-	488	548	261	301	670	440	992	1137
WM-L30/3-A R	956	637	285-325	58	-	494	548	261	301	670	440	992	1137
WM-G30/1-A ZM	1146	827	349-374	248	128	398	508	261	301	570	440	992	1111
WM-G30/2-A ZM	1146	827	349-374	248	128	398	548	261	301	610	440	992	1137
WM-G30/3-A ZM	1166	847	349-389	268	148	398	548	261	348	670	440	992	1137
WM-G30/4-A ZM	1166	847	349-389	268	148	398	548	261	348	670	440	992	1137
WM-GL30/1-A ZM-T	1146	827	349-374	248	128	612	508	261	301	570	440	1038	1111
WM-GL30/2-A ZM-T	1146	827	349-374	248	128	610	548	261	301	670	440	1048	1137
WM-GL30/1-A ZM-R	1146	827	349-374	248	128	615	508	261	301	570	440	1052	1111
WM-GL30/2-A ZM-R	1146	827	349-374	248	128	619	548	261	301	670	440	1055	1137
WM-GL30/3-A ZM-R	1166	847	349-389	268	148	625	548	261	348	670	440	1059	1137
WM-G30/1-A ZM-LN	1146	827	384-404	248	128	398	508	261	301	570	440	992	1111
WM-G30/2-A ZM-LN	1146	827	374-414	248	128	398	548	261	301	610	440	992	1137
WM-G30/3-A ZM-LN	1166	847	395-420	268	148	398	548	261	348	670	440	992	1137
WM-G30/4-A ZM-LN	1146	847	395-425	268	148	398	548	261	348	670	440	992	1137

All dimensions are approximate. Weishaupt reserve the right to make changes in light of future developments.
 * Excluding frequency converter.
 ** May differ for special voltages.

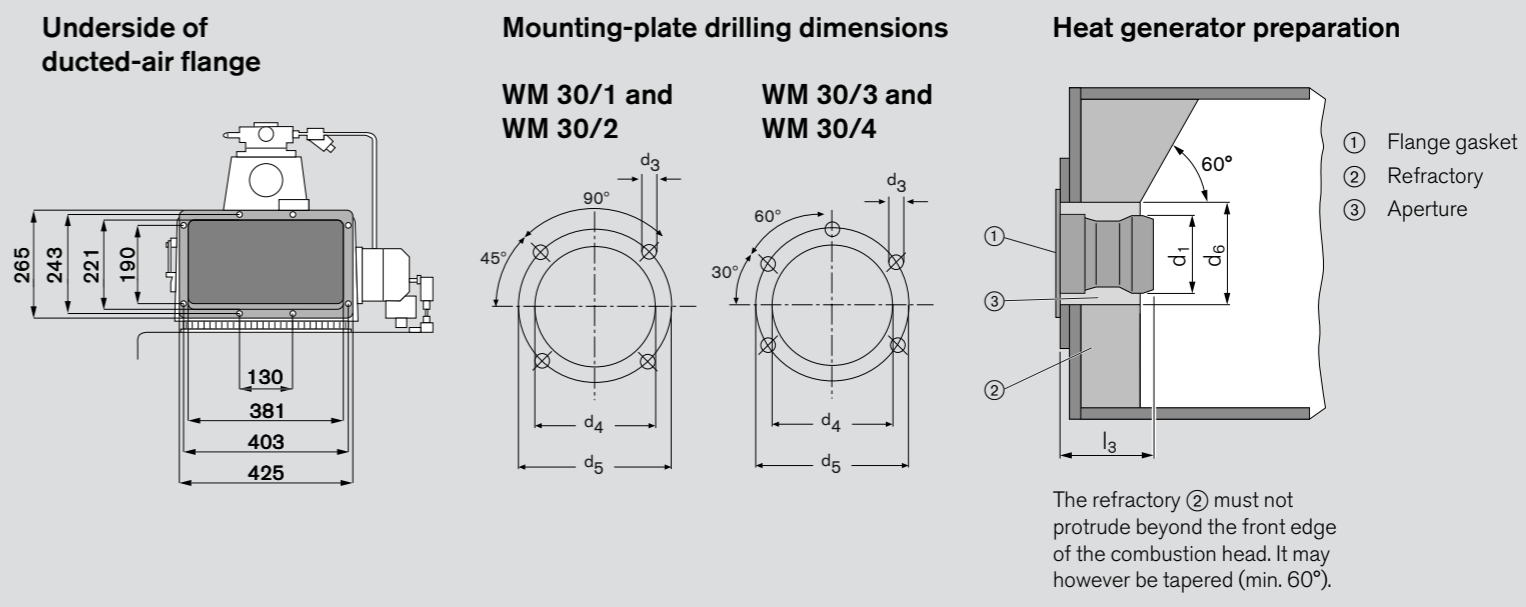

Burner type	Dimensions in mm													Nominal diameter of gas butterfly
	h ₁	h ₂	h ₃	h ₄	h ₅	h ₆	d ₁	d ₂	d ₃	d ₄	d ₅	d ₆		
WM-L30/1-A T	695	256	505	-	621	680	290	380	M12	305	330	360	-	
WM-L30/2-A T	695	256	505	-	621	680	300	380	M12	305	330	360	-	
WM-L30/1-A R	695	256	505	-	621	710	290	380	M12	305	330	360	-	
WM-L30/2-A R	695	256	505	-	621	720	300	380	M12	305	330	360	-	
WM-L30/3-A R	730	256	505	-	621	720	367	450	M12	375	400	420	-	
WM-G30/1-A ZM	695	256	505	212	621	-	290	380	M12	305	330	360	DN 80	
WM-G30/2-A ZM	695	256	505	212	621	-	300	380	M12	305	330	360	DN 80	
WM-G30/3-A ZM	730	256	505	232	621	-	367	450	M12	375	400	420	DN 80	
WM-G30/4-A ZM	730	256	505	232	621	-	367	450	M12	375	400	420	DN 80	
WM-GL30/1-A ZM-T	695	256	505	212	621	680	290	380	M12	305	330	360	DN 80	
WM-GL30/2-A ZM-T	695	256	505	212	621	680	300	380	M12	305	330	360	DN 80	
WM-GL30/1-A ZM-R	695	256	505	212	621	710	290	380	M12	305	330	360	DN 80	
WM-GL30/2-A ZM-R	695	256	505	212	621	720	300	380	M12	305	330	360	DN 80	
WM-GL30/3-A ZM-R	730	256	505	232	621	720	367	450	M12	375	400	420	DN 80	
WM-G30/1-A LN	695	256	505	212	621	-	280	380	M12	305	330	360	DN 80	
WM-G30/2-A LN	695	256	505	212	621	-	296	380	M12	305	330	360	DN 80	
WM-G30/3-A LN	730	256	505	232	621	-	356	450	M12	375	400	420	DN 80	
WM-G30/4-A LN	730	256	505	232	621	-	356	450	M12	375	400	420	DN 80	

All dimensions are approximate. Weishaupt reserve the right to make changes in light of future developments.

Saving fuel, reducing emissions: Patented multiflam[®] technology



Weishaupt's patented multiflam[®] technology enables large combustion plant to meet very low emission limits without the need for expensive additional equipment. This reduction in emissions is achieved by using an innovative mixing assembly and fuel distribution system.

Weishaupt multiflam[®] burners have been proving themselves in the field for more than 10 years. They are especially suited to markets with stringent emission limits.

Monarch[®] burners bring this technology to medium-capacity ranges, combining flexibility with extremely low emissions.

Exemplary emissions

At the heart of Weishaupt's multiflam[®] technology lies a special mixing assembly design. Fuel is distributed among several nozzles and combusted in a primary and a secondary flame. Temperature in the flame's core is considerably reduced, resulting in an effective reduction of nitrogen oxides.

Good combustion figures also depend on combustion chamber geometry, volumetric loading and boiler design (three-pass type). Certain conditions (including, for example, combustion chamber loading, measurement tolerances, temperature, pressure, humidity etc.) must be observed in order for a guarantee of emission levels to be given.

Burner selection WM-L30, version 3LN (multiflam[®])

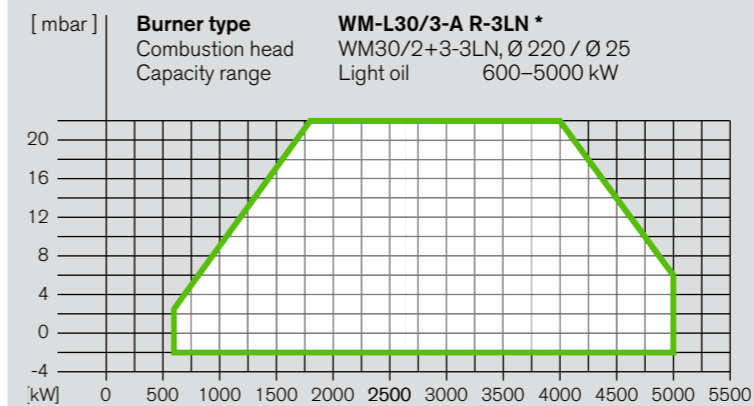
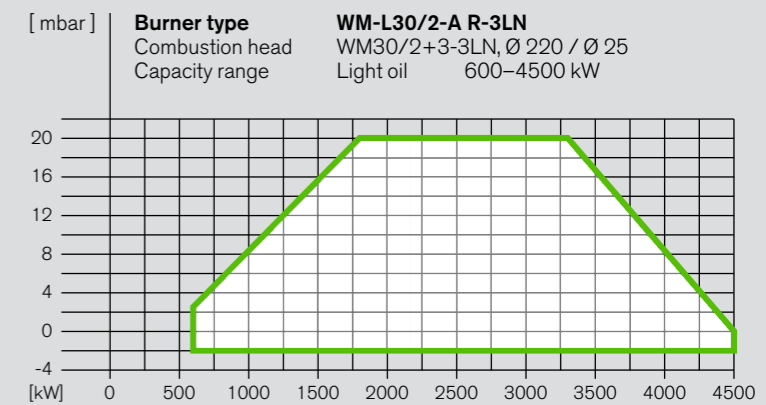
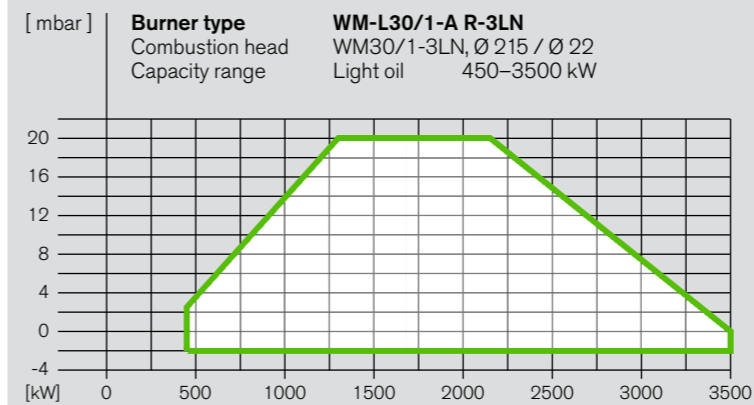

* 57-Hz version with VSD

Fuels:

Light oil

Capacity graphs for oil burners certified in accordance with EN 267.

Stated ratings are based on an air temperature of 20 °C and an installation altitude of 500 m above sea level.

Stated oil throughputs are based on a nett calorific value (LHV) of 11.9 kWh/kg.

DIN CERTCO certification:

The burners have been type-tested by an independent body (TÜV-Süd) and certified by DIN CERTCO.

Turndown:

Light oil max. 5:1

Burner selection WM-G30 and WM-GL30, vers. 3LN (multiflam®)

Gas valve train sizing WM-G30 and WM-GL30, vers. 3LN (multiflam®)

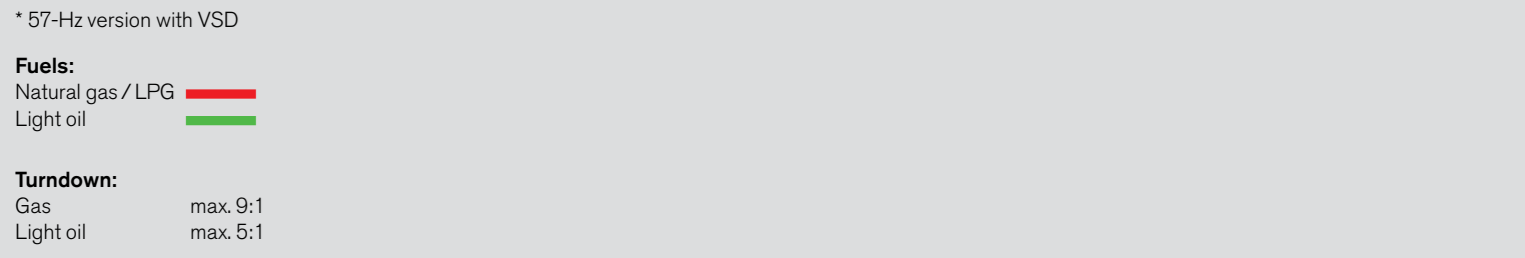
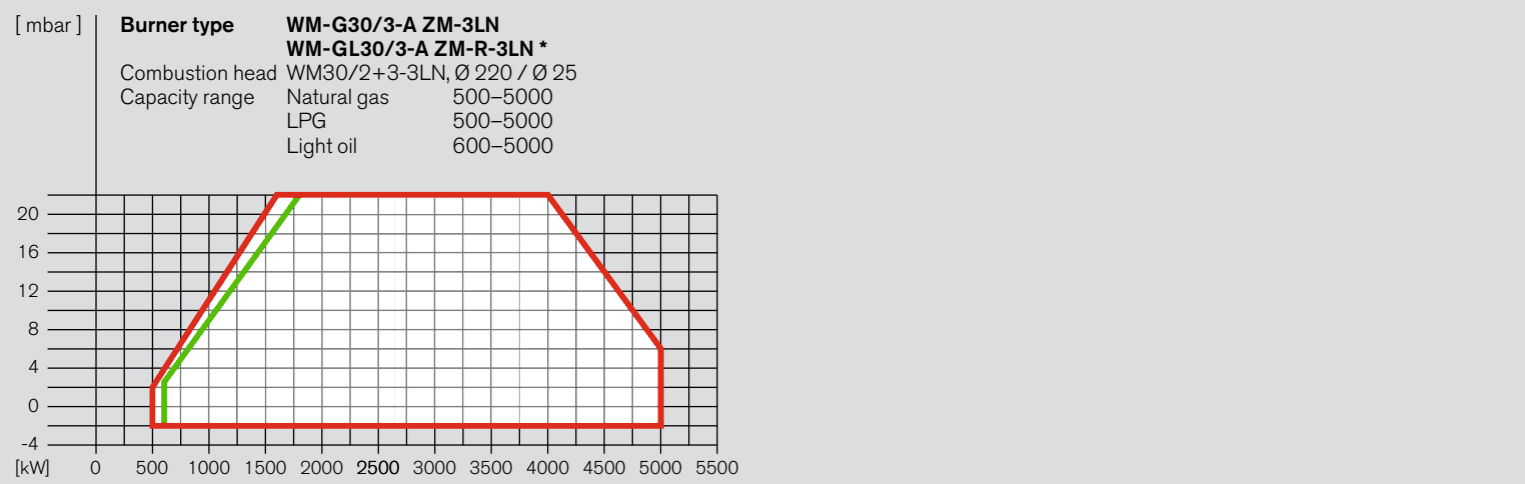
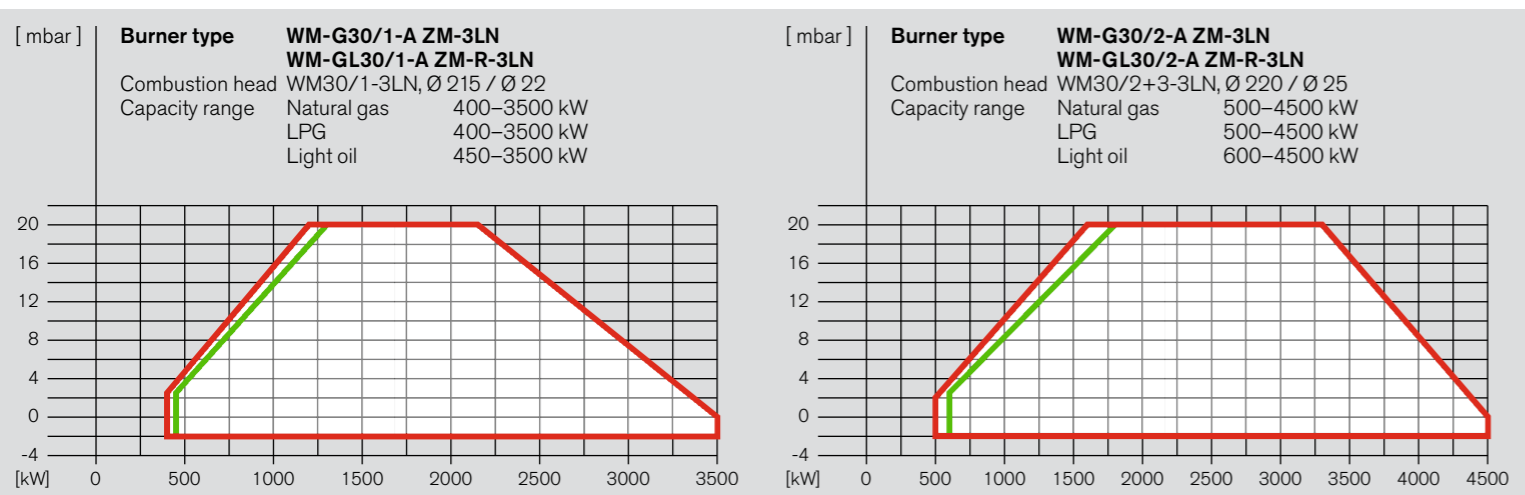

* 57-Hz version with VSD

Fuels:
Natural gas / LPG —
Light oil —

Turndown:
Gas max. 9:1
Light oil max. 5:1

Capacity graphs for gas and dual-fuel burners certified in accordance with EN 676 and EN 267.

Stated ratings are based on an air temperature of 20 °C and an installation at sea level. For installations at higher altitudes, a reduction in capacity of 1 % per 100 m above sea level should be taken into account.

WM-G(L)30/1-A, version ZM(-R)-3LN (multiflam®)		WM-G(L)30/2-A, version ZM(-R)-3LN (multiflam®)	
Burner rating kW	Low-pressure supply (with FRS) (flow pressure in mbar into shutoff valve, P ₁ ≤ 300 mbar)	High-pressure supply (with HP regulator) (flow pressure in mbar into gas valve assembly)	
	Nominal valve train diameter 1½" 2" 65 80 100 125 Nominal diameter of gas butterfly 80 80 80 80 80 80	Nominal valve train diameter 1½" 2" 65 80 100 125 Nominal diameter of gas butterfly 80 80 80 80 80 80	
Natural gas E LHV = 10.35 kWh/Nm ³ ; d = 0.606			
1300	77 37 27 23 21 20	46 24 19 18 17 17	
1600	109 48 33 27 23 22	63 30 23 21 20 19	
2000	162 67 43 33 28 27	91 40 29 26 24 23	
2300	210 84 52 40 33 31	117 49 35 31 28 27	
2700	284 111 67 49 40 37	157 63 44 38 34 33	
3100	- 142 84 61 49 45	- 80 55 47 42 40	
3500	- 177 103 75 59 54	- 100 67 57 50 48	
Natural gas LL LHV = 8.83 kWh/Nm ³ ; d = 0.641			
1300	110 51 37 31 28 27	66 34 27 25 24 24	
1600	155 67 44 36 31 29	90 41 32 29 27 26	
2000	232 93 58 44 37 35	130 55 39 35 31 31	
2300	- 117 71 52 43 40	167 67 47 41 36 35	
2700	- 155 90 66 52 48	- 87 59 50 44 43	
3100	- 199 114 81 64 58	- 110 73 62 54 52	
3500	- 249 141 100 77 70	- 137 90 75 65 63	
LPG * LHV = 25.89 kWh/Nm ³ ; d = 1.555			
1300	46 30 26 24 23 23	32 23 21 21 20 20	
1600	59 34 27 25 24 23	38 25 22 21 21 20	
2000	80 41 31 27 25 25	50 29 24 23 22 22	
2300	100 48 35 30 27 27	61 33 27 25 24 24	
2700	131 60 42 35 31 30	78 39 31 29 27 27	
3100	168 75 51 41 36 35	99 48 37 34 32 31	
3500	211 91 61 49 43 41	123 58 45 41 38 37	

WM-G(L)30/3-A, version ZM(-R)-3LN (multiflam®)		Screwed		Flanged	
Burner rating kW	Low-pressure supply (with FRS) (flow pressure in mbar into shutoff valve, P ₁ ≤ 300 mbar)	High-pressure supply (with HP regulator) (flow pressure in mbar into gas valve assembly)		Nominal valve train diameter	
	Nominal valve train diameter 1½" 2" 65 80 100 125 150 Nominal diameter of gas butterfly 80 80 80 80 80 80	Nominal valve train diameter 1½" 2" 65 80 100 125 150 Nominal diameter of gas butterfly 80 80 80 80 80 80		Nominal diameter of gas butterfly	
Natural gas E LHV = 10.35 kWh/Nm ³ ; d = 0.606					
2100	171 66 39 29 23 22 21	93 36 25 21 19 18 18	DN 65	DMV 5065/12	
2500	239 90 52 37 29 27 26	130 49 32 27 24 23 23	DN 80	DMV 5080/12	
2900	- 118 67 47 36 33 31	172 63 41 34 30 28 28	DN 100	DMV 5100/12	
3300	- 150 84 58 44 40 38	- 80 51 42 36 35 34	DN 125	VDG 40.125	
3700	- 185 102 70 53 47 45	- 99 62 51 43 41 41	DN 150	VDG 40.150	
4100	- 225 123 84 62 56 53	- 119 74 61 51 49 48			
4500	- 269 146 99 73 65 61	- 141 88 71 60 57 56			
5000	- - 177 119 87 77 72	- 172 106 86 72 68 67			
Natural gas LL LHV = 8.83 kWh/Nm ³ ; d = 0.641					
2100	244 91 35 37 29 27 25	132 49 32 27 23 22 22			
2500	124 49 48 37 33 31	183 66 42 34 29 28 28			
2900	- 163 69 61 45 40 38	- 86 53 43 36 35 34			
3300	- 208 95 75 55 49 46	- 108 66 53 45 42 41			
3700	- 259 125 92 66 58 55	- 134 81 65 54 51 50			
4100	- - 160 110 79 69 65	- 162 97 78 64 60 59			
4500	- - 199 130 93 81 75	- 194 115 92 75 71 69			
5000	- - 243 158 112 97 91	- - 140 111 91 85 84			
LPG * LHV = 25.89 kWh/Nm ³ ; d = 1.555					
2100	79 36 25 21 18 18 17	46 22 17 16 15 15 15			
2500	108 47 31 25 22 21 21	62 29 22 20 18 18 18			
2900	142 60 39 31 27 25 25	81 36 27 24 23 22 22			
3300	182 75 48 38 32 30 29	103 45 33 30 27 27 26			
3700	226 92 58 45 38 36 35	128 55 40 36 33 32 32			
4100	276 112 70 54 45 42 41	156 67 48 43 39 38 38			
4500	- 133 83 63 53 49 48	187 79 57 51 46 45 44			
5000	- 163 101 76 63 59 57	- 97 70 61 56 54 54			

* The LPG charts are based on propane, but may also be used for butane.

Scope of delivery

Description	WM-L30 R-3LN	WM-G30 ZM-3LN	WM-GL30 ZM-R-3LN
Burner housing, hinged flange, housing cover, Weishaupt burner motor, air inlet housing, fan wheel, combustion head, ignition unit, ignition cable, ignition electrodes, combustion manager with control unit, flame sensor, actuators, flange gasket, limit switch on hinged flange, fixing screws	●	●	●
Digital combustion manager W-FM 100 W-FM 200	● ●	● ●	● ●
WM30/1, WM30/2 WM30/3			
Valve proving via the combustion manager	–	●	●
Class-A double gas valve assembly	–	●	●
Gas butterfly valve	–	●	●
Air pressure switch	○	●	●
Low gas pressure switch	–	●	●
Mixing assembly with modulating diffuser	●	●	●
Actuators for compound regulation of fuel and air via W-FM: Air damper actuator Gas butterfly valve actuator Oil regulator actuator Mixing assembly actuator	● – ● ●	● ● – ●	● ● ● ●
Oil pressure switch in return	●	–	●
DSB158 oil pressure switch in supply	○ ●	– –	○ ●
WM30/1, WM30/2 WM30/3			
Oil pump fitted to burner ¹⁾	●	–	●
Oil hoses	●	–	●
Supply and return with 2 oil solenoids, oil regulator, nozzle head, premounted nozzles	●	–	●
Electromagnetic clutch ¹⁾	○ –	– –	● –
WM30/1, WM30/2 WM30/3			
Star-delta combination, fitted to motor ¹⁾	● –	● –	● –
WM30/1, WM30/2 WM30/3			
Variable speed drive	○ ●	○ ●	○ ●
WM30/1, WM30/2 WM30/3			
IP 54 protection	●	●	●

EN 676 stipulates that ball valves, gas filters, and gas pressure regulators form part of the burner supply (see Weishaupt accessories list). Please enquire or see the special equipment section of this brochure for further burner executions.

- Standard
- Optional

¹⁾ WM30/3 burners are equipped as standard with a frequency convertor (full load = 57 Hz) and a burner-mounted, motorised oil pump, type SMG1629.

Order numbers

Oil burners

Burner type	Version	Order No.
WM-L30/1-A	R-3LN	215 320 11
WM-L30/2-A	R-3LN	215 320 21
WM-L30/3-A	R-3LN	215 320 31

DIN CERTCO: 5G1046

Gas burners

Burner type	Version	Valve train size	Order No.
WM-G30/1-A	ZM-3LN	R 1½	217 317 12
		R 2	217 317 13
		DN 65	217 317 14
		DN 80	217 317 15
		DN 100	217 317 16
WM-G30/2-A	ZM-3LN	DN 125	217 317 17
		R 1½	217 318 12
		R 2	217 318 13
		DN 65	217 318 14
		DN 80	217 318 15
WM-G30/3-A	ZM-3LN	DN 100	217 318 16
		DN 125	217 318 17
		R 1½	217 319 12
		R 2	217 319 13
		DN 65	217 319 14
		DN 80	217 319 15
		DN 100	217 319 16
		DN 125	217 319 17
		DN 150	217 319 18

CE-PIN: CE-0085BU0359

Dual-fuel burners

Burner type	Version	Valve train size	Order No.
WM-GL30/1-A	ZM-R-3LN	R 1½	218 325 12
		R 2	218 325 13
		DN 65	218 325 14
		DN 80	218 325 15
		DN 100	218 325 16
WM-GL30/2-A	ZM-R-3LN	DN 125	218 325 17
		R 1½	218 326 12
		R 2	218 326 13
		DN 65	218 326 14
		DN 80	218 326 15
WM-GL30/3-A	ZM-R-3LN	DN 100	218 326 16
		DN 125	218 326 17
		R 1½	218 327 12
		R 2	218 327 13
		DN 65	218 327 14
		DN 80	218 327 15
		DN 100	218 327 16
		DN 125	218 327 17
		DN 150	218 327 18

CE-PIN: CE-0085BU0360
DIN CERTCO: 5G1044M

Special equipment WM-L30, version 3LN (multiflam®)

Oil burners, version R-3LN	WM-L30/1-A	WM-L30/2-A	WM-L30/3-A
Pressure gauge with ball valve on pump	110 002 82	110 002 82	–
Pressure gauge with ball valve in return	110 011 50	110 011 50	–
Vacuum gauge with ball valve	110 017 00	110 017 00	–
Combustion head extension	by 150 mm	Please enquire	Please enquire
	by 300 mm	Please enquire	Please enquire
Air inlet flange for ducted-air connection, with LGW air pressure switch (LGW 50 also required)	210 031 15	210 031 15	–
LGW 50 air pressure switch ¹⁾	210 031 39	210 031 39	–
ST 18/7 and ST 18/4 plug connections	250 030 22	250 030 22	250 030 22
W-FM 100 supplied loose in lieu of fitted	210 032 21	210 032 21	–
W-FM 200 supplied loose in lieu of fitted	–	–	210 032 23
Integral load controller and analogue signal convertor for W-FM 100	110 017 18	110 017 18	–
W-FM 200 in lieu of W-FM 100 with integral load controller, analogue signal convertor, and VSD module with optional fuel metering	burner-mounted	210 031 61	210 031 61
	supplied loose	210 032 22	210 032 22
DSB158 pressure switch in supply ¹⁾	210 031 09	210 031 09	Standard
VSD with integral frequency convertor (W-FM 200 required)	210 031 48	210 031 49	Standard
VSD with separate frequency convertor (W-FM 200 required) (See accessories list for frequency convertor)	210 030 98	210 031 00	Please enquire
W-FM 200 with extended O ₂ trim / CO control functionality	Please enquire	Please enquire	Please enquire
ABE with Chinese-character display, supplied loose	110 018 53	110 018 53	110 018 53
Special voltage (on application only)	Please enquire	Please enquire	Please enquire
110 V control voltage	Please enquire	Please enquire	Please enquire

Country-specific executions and special voltages on application

¹⁾ Required for PED (2014/68/EU) compliance.

Special equipment WM-G30 and WM-GL30, vers. 3LN (multiflam®)

Gas and dual-fuel burners, version ZM(-R)-3LN		WM-G(L)30/1-A	WM-G(L)30/2-A	WM-G(L)30/3-A
Combustion head extension	by 150 mm	Please enquire	Please enquire	Please enquire
	by 300 mm	Please enquire	Please enquire	Please enquire
Solenoid valve for air pressure switch test with continuous-run fan or post-purge		Please enquire	Please enquire	Please enquire
High gas pressure switch ¹⁾ (Screwed R ³ / ₄ to R2 for low-pressure supplies)	GW 50 A6/1	250 033 30	250 033 30	250 033 30
	GW 150 A6/1	250 033 31	250 033 31	250 033 31
	GW 500 A6/1	250 033 32	250 033 32	250 033 32
High gas pressure switch ¹⁾ (Flanged DMV / VGD for low-pressure supplies)	GW 50 A6/1	150 017 49	150 017 49	150 017 49
	GW 150 A6/1	150 017 50	150 017 50	150 017 50
	GW 500 A6/1	150 017 51	150 017 51	150 017 51
High gas pressure switch ¹⁾ (Fitted to high-pressure regulator)	GW 50 A6/1	250 033 33	250 033 33	250 033 33
	GW 150 A6/1	250 033 34	250 033 34	250 033 34
	GW 500 A6/1	250 033 35	250 033 35	250 033 35
ST 18/7 and ST 18/4 plug connections		250 030 22	250 030 22	250 030 22
Air inlet flange for ducted-air connection, with LGW air pressure switch		210 031 15	210 031 15	–
DSB158 pressure switch in supply ¹⁾		210 031 09	210 031 09	Standard
W-FM 100 supplied loose in lieu of fitted		250 034 28	250 034 28	–
W-FM 200 supplied loose in lieu of fitted		–	–	250 034 30
Integral load controller and analogue signal convertor for W-FM 100		110 017 18	110 017 18	–
W-FM 200 in lieu of W-FM 100 with integral load controller, analogue signal convertor, and VSD module with optional fuel metering	burner-mounted	250 030 72	250 030 72	Standard
	supplied loose	250 034 29	250 034 29	–
VSD with integral frequency convertor (W-FM 200 required)	WM-G	210 030 97	210 031 49	Standard
	WM-GL	210 031 48	210 031 49	Standard
VSD with separate frequency convertor (W-FM 200 required) (See accessories list for frequency convertor)		210 030 98	210 031 00	210 031 57
W-FM 200 with extended O ₂ trim / CO control functionality		250 033 78	250 033 78	250 033 78
Mixing assembly with HDK 40 in lieu of HDK 30 (for media temperatures > 120 °C)	WM-GL	210 031 86	210 031 86	210 031 86
ABE with Chinese-character display, supplied loose		110 018 53	110 018 53	110 018 53
110 V control voltage		Please enquire	Please enquire	Please enquire

Country-specific executions and special voltages on application

¹⁾ Required for PED (2014/68/EU) compliance.

Technical data

WM 30, version 3LN (multiflam®)

Oil burners, version R-3LN		WM-L30/1-A	WM-L30/2-A	WM-L30/3-A ²⁾
Burner motor	Weishaupt type	WM-D 132/210-2/10K0	WM-D 132/210-2/14K0	WM-D 132/210-2/17K0
Motor power output	kW	10	14	17
Nominal current	A	22	28	34
Motor protection switch ¹⁾ or motor prefusing ¹⁾	type (e.g.) A minimum	PKE32/XTU-32 35 A gG / T (by others)	PKE32/XTU-32 50 A gG / T (by others)	PKE65/XTU-65 50 A gG / T (by others)
Speed (50 Hz)	rpm	2940	2920	3320
Combustion manager	type	W-FM 100	W-FM 100	W-FM 200
Flame monitoring	type	QRA73	QRA73	QRA73
Air damper / oil actuator Mixing assembly actuator	type type	SQM45 SQM45	SQM45 SQM48	SQM45 SQM48
NO _x Class per EN 267		3	3	3
Mass	kg	approx. 202	approx. 202	approx. 240
Integral pump max. flow rate	type l/h	TA4 1050	TA5 1410	SMG 1629 (motorised) 1500
Oil hoses	DN / length	25 / 1300	25 / 1300	25 / 1300

¹⁾ The necessary motor protection can be provided either by a motor protection switch (supplied and fitted into a panel by others), or with integral motor overload protection (see special equipment).

²⁾ Full load achieved via 57 Hz frequency convertor (no IE marking).

Voltages and frequencies:

The burners are equipped as standard for three-phase alternating current, 400 V, 3 ~, 50 Hz. Other voltages and frequencies are available on application.

Standard burner motor:

Insulation Class F, IP 55 protection.
IE3 Premium Efficiency

Gas burners, version ZM-3LN		WM-G30/1-A	WM-G30/2-A	WM-G30/3-A ²⁾
Burner motor	Weishaupt type	WM-D 132/210-2/10K0	WM-D 132/210-2/14K0	WM-D 132/210-2/17K0
Motor power output	kW	10	14	17
Nominal current	A	22	28	34
Motor protection switch ¹⁾ or motor prefusing ¹⁾	type (e.g.) A minimum	PKE32/XTU-32 35 A gG / T (by others)	PKE32/XTU-32 50 A gG / T (by others)	PKE65/XTU-65 50 A gG / T (external)
Speed (50 Hz)	rpm	2940	2920	3320
Combustion manager	type	W-FM 100	W-FM 100	W-FM 200
Flame monitoring	type	ION	ION	ION
Air damper / gas actuator Mixing assembly actuator	type type	type SQM45	SQM45 SQM48	SQM45 SQM48
NO _x Class per EN 676		3	3	3
Mass (excl. double gas valve assembly and fittings)	kg	approx 184	approx. 184	approx 199

Dual-fuel burners, version ZM-R-3LN		WM-GL30/1-A	WM-GL30/2-A	WM-GL30/3-A ²⁾
Burner motor	Weishaupt type	WM-D 132/210-2/10K0	WM-D 132/210-2/14K0	WM-D 132/210-2/17K0
Motor power output	kW	10	14	17
Nominal current	A	22	28	34
Motor protection switch ¹⁾ or motor prefusing ¹⁾	type (e.g.) A minimum	PKE32/XTU-32 35 A gG / T (by others)	PKE32/XTU-32 50 A gG / T (by others)	PKE65/XTU-65 50 A gG / T (by others)
Speed (50 Hz)	rpm	2940	2920	3320
Combustion manager	type	W-FM 100	W-FM 100	W-FM 200
Flame monitoring	type	QRA73	QRA73	QRA73
Air damper / gas / oil actuator Mixing assembly actuator	type type	SQM45 SQM45	SQM45 SQM48	SQM45 SQM48
NO _x Class per EN 676 / EN 267		3	3	3
Mass (excl. double gas valve assembly and fittings)	kg	approx. 217	approx. 217	approx. 245
Integral pump	type	TA4	TA5	SMG 1629 (motorised)
Motor power output	kW	–	–	2.2
Nominal current	A	–	–	4.65
Max. flow rate	l/h	1050	1410	1500
Oil hoses	DN / length	25/1300	25/1300	25/1300

¹⁾ The necessary motor protection can be provided either by a motor protection switch (supplied and fitted into a panel by others), or with integral motor overload protection (see special equipment).

²⁾ Full load achieved via 57 Hz frequency convertor (no IE marking).

Voltages and frequencies:

The burners are equipped as standard for three-phase alternating current, 400 V, 3 ~, 50 Hz. Other voltages and frequencies are available on application.

Standard burner motor:

Insulation Class F, IP 55 protection.
IE3 Premium Efficiency

Dimensions

multiflam® burners, version 3LN

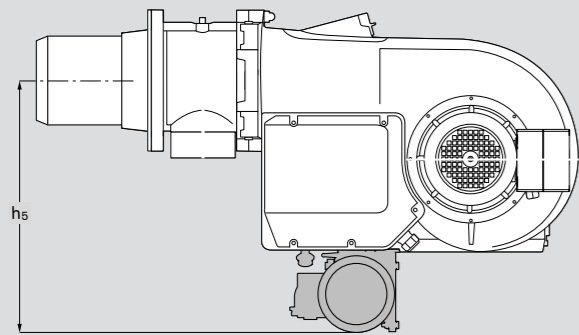
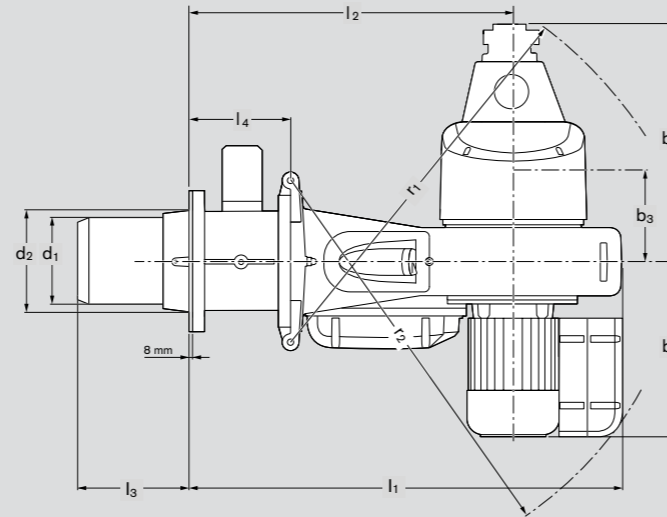
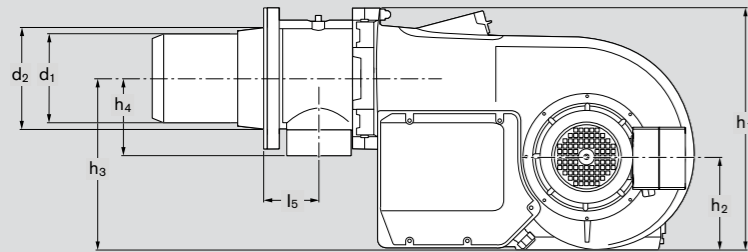

Motorised oil pump
(Standard on WM 30/3)

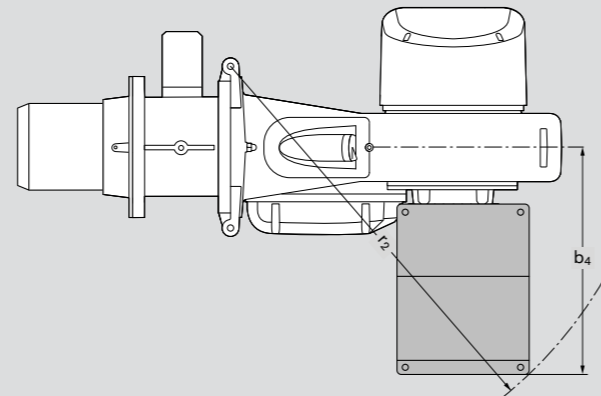

Frequency converter
(Standard on WM 30/3)

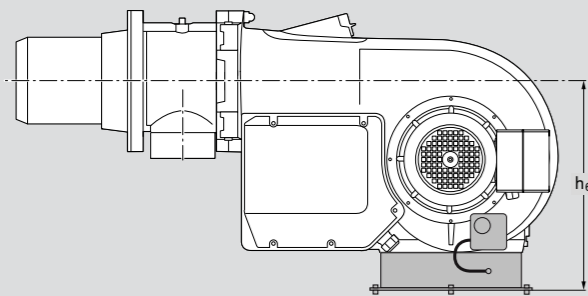

Ducted-air flange

Optional

Burner type	Dimensions in mm															
	l ₁	l ₂	l ₃	l ₄	l ₅	b ₁	b ₂	b ₃	b ₄ **	h ₁	h ₂	h ₃	h ₄	h ₅	h ₆	
WM-L30/1-A R-3LN	1166	847	473	268	148	488	548	261	670	730	256	505	-	720	621	
WM-L30/2-A R-3LN	1166	847	480	268	148	494	548	261	670	730	256	505	-	720	621	
WM-L30/3-A R-3LN	1166	847	480	268	148	446	548	261	670	730	256	505	-	720	621	
WM-G30/1-A ZM-3LN	1166	847	473	268	148	398	548	261	610	730	256	505	232	-	621	
WM-G30/2-A ZM-3LN	1166	847	480	268	148	398	548	261	670	730	256	505	232	-	621	
WM-G30/3-A ZM-3LN	1166	847	480	268	148	398	548	261	670	730	256	505	232	-	621	
WM-GL30/1-A ZM-R-3LN	1166	847	473	268	148	619	548	261	670	730	256	505	232	720	621	
WM-GL30/2-A ZM-R-3LN	1166	847	480	268	148	625	548	261	670	730	256	505	232	720	621	
WM-GL30/3-A ZM-R-3LN	1166	847	480	268	148	446	548	261	670	730	256	505	232	720	621	

Burner type	Dimensions in mm				Nominal diameter of gas butterfly	d ₃	d ₄	d ₅	d ₆
	r ₁	r ₂ *	d ₁	d ₂					
WM-L30/1-A R-3LN	992	1137	296	348	M12	375	400	380	
WM-L30/2-A R-3LN	992	1137	322	348	M12	375	400	380	
WM-L30/3-A R-3LN	992	1151	322	348	M12	375	400	380	
WM-G30/1-A ZM-3LN	992	1137	296	348	DN80	M12	375	400	380
WM-G30/2-A ZM-3LN	992	1137	322	348	DN80	M12	375	400	380
WM-G30/3-A ZM-3LN	992	1151	322	348	DN80	M12	375	400	380
WM-GL30/1-A ZM-R-3LN	1055	1137	296	348	DN80	M12	375	400	380
WM-GL30/2-A ZM-R-3LN	1059	1137	322	348	DN80	M12	375	400	380
WM-GL30/3-A ZM-R-3LN	992	1151	322	348	DN80	M12	375	400	380

All dimensions are approximate.
Weishaupt reserve the right to make changes in light of future developments.
* Excluding frequency converter.
** May differ for special voltages.

Mounting-plate drilling dimensions

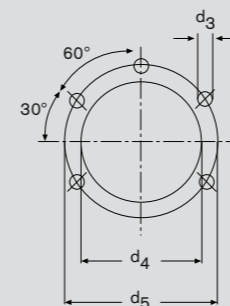

Heat generator preparation

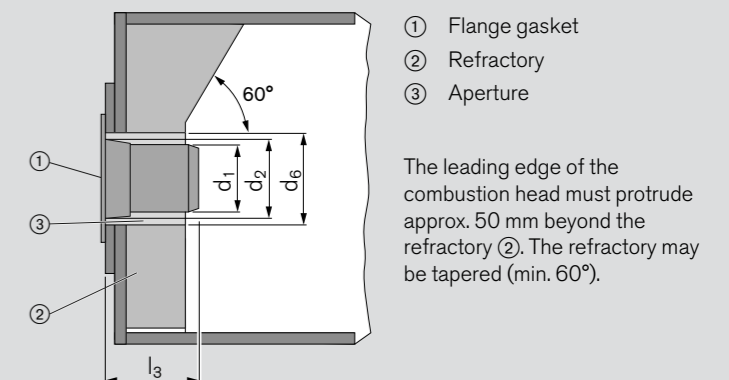

Contact Us

Maximising Energy Efficiencies for a Sustainable Future

admin@egl.com.au www.environmental.com.au 03 9541 8699

Office Locations



Melbourne
 Tomlinson Energy Services
 Suite 2.01 | Level 2
 315 Ferntree Gully Road
 Mount Waverley VIC 3149
 P: 03 8560 0416
 E: energyservice.melbourne@tomlinsonenergy.com.au

Sydney
 Tomlinson Energy Services
 A2, 26 Power Road
 Seven Hills NSW 2417
 P: 02 9681 4177
 E: energyservice.sydney@tomlinsonenergy.com.au

Brisbane
 Tomlinson Energy Services
 1/48 Commerce Circuit
 Yatala QLD 4207
 P: 07 3462 0159
 E: energyservice.brisbane@tomlinsonenergy.com.au

South Australia
 Tomlinson Energy Services
 26 Phillips Street
 Thebarton SA 5031
 P: 08 8297 9688
 E: energyservice.adelaide@tomlinsonenergy.com.au

Western Australia
 Tomlinson Energy Services
 40 Sorbonne Crescent
 Canning Vale WA 6155
 P: 08 9455 5511
 E: energyservice.perth@tomlinsonenergy.com.au



Fuel systems

Gas-side fuel system

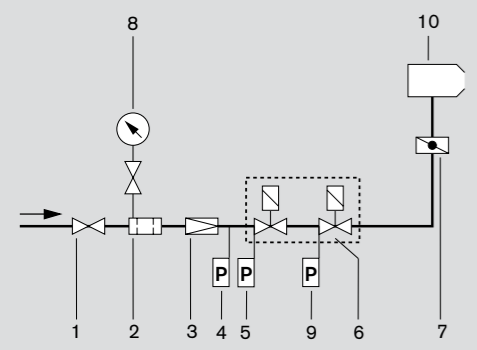

- 1 Ball valve *
- 2 Gas filter *
- 3 Pressure regulator, (LP) or (HP) *
- 4 High gas pressure switch *
- 5 Low gas pressure switch
- 6 Double gas valve assembly
- 7 Gas butterfly valve
- 8 Pressure gauge with push-button valve *
- 9 Valve-proving pressure switch
- 10 Burner

* Not included in burner price

Mounting position of the high gas pressure switch:
 On the regulator outlet of HP trains
 After the regulator of screwed LP trains
 On the valve assembly inlet of flanged LP trains
 Cable length approx. 2.5 m.

Layout of the valve train

On boilers with hinged doors, the valve train must be mounted on the opposite side to the boiler-door hinges.

Compensator

To enable a tension free mounting of the valve train, the fitting of a compensator is strongly recommended.

Break points in the valve train

Break points in the valve train should be provided to enable the door of the heat generator to be swung open. The main gas line is best separated at the compensator.

Support of the valve train

The valve train should be properly supported in accordance with the site conditions. See the Weishaupt accessories list for various valve train support components.

Gas meter

A gas meter must be installed to measure gas consumption during commissioning and servicing.

Optional thermal shutoff (when required by local regulations)

Integrated into the ball valve of screwed valve trains. A separate component with HTB seals fitted before the ball valve on flanged valve trains.

Oil-side fuel system

WM30/1 and WM30/2

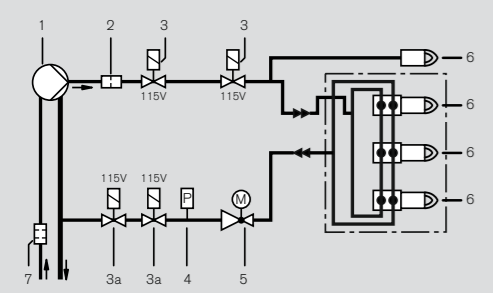

WM30/3

with motorised SMG 1629 pump

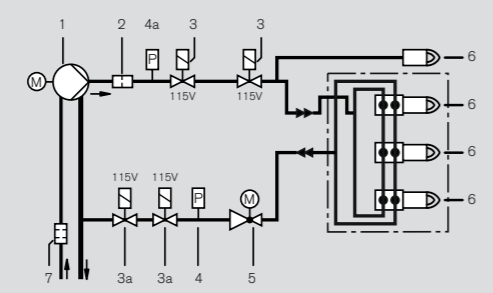

- 1 Oil pump
- 2 Strainer
- 3 Normally closed oil solenoid valve (115 V, switched in series with 3a)
- 3a Normally closed oil solenoid valve (115 V, switched in series with 3, fitted against the direction of flow)
- 4 Oil pressure switch in return
- 4a Oil pressure switch in supply
- 5 Oil regulator
- 6 Nozzle assembly with shutoff device
- 7 External oil filter ^⓪

^⓪ Not included in burner price.