



High-Performance Packaged Boiler

Australia's largest certified
package boiler company.



**The Environmental
Group Limited**
Engineering a Sustainable Future

The Environmental Group Limited

www.environmental.com.au

Working across the Circular Economy

Our Purpose

Engineering a sustainable future.

Our Mission

To enable our clients to contribute to a cleaner environment by safely delivering pivotal solutions while generating value for our shareholders, staff, and partner industries.

Our Team

Our local experts are dedicated to reducing waste and boosting energy performance. Trusted worldwide to provide the highest standards of service and support.

Tomlinson Energy Services

Part of The Environmental Group

Tomlinson Energy Services is Australia's leading provider of packaged boiler solutions, delivering the highest combustion efficiency to keep operating costs low and performance high.

We specialise in custom design, installation, commissioning, and national servicing and repairs, complemented by our 24/7 emergency support.

With offices and a dedicated service team across Australia, Tomlinson Energy Services ensures boilers operate at peak performance for maximum efficiency and reliability.



Offering Industry Leading Burners

Weishaupt produces gas and oil-fired boilers, heat pumps, and burners. These top-quality products are characterised by their meticulous development, high-quality workmanship, outstanding operational reliability, and maximum Efficiency. Their unrivalled excellence extends equally to design and function.

WEISHAUPT OIL BURNERS WL5 TO WL40



Digital oil burners

A burning passion for quality



Ultra-modern research and production methods, rigorous quality control, and a comprehensive service network ensure the quality for which Weishaupt is renowned

Technological progress is our motivation. It has been driving us for more than 65 years to keep setting new standards for the combustion equipment industry.

Our own Research and Development Centre is constantly working both on the development of new products and on the optimisation of existing ones.

We consider it is not only our goal but our responsibility to go above and beyond current legislative requirements to develop combustion systems which emit ever fewer pollutants, save ever more energy, and combine ecology and economy in a practical manner.

Therefore, not only do we invest in research and technology, but we also only ever work with the best materials, using the latest tools, and we carry out meticulous quality control checks.

Millions of times over, Weishaupt burners have proven to heating specialists and end users alike that they are extremely reliable, durable, environmentally friendly, and technologically advanced; a fact also borne out by our numerous prizes for design and innovation.

Burners with outputs ranging from 12.5 to 32000 kW are manufactured at our ultra-modern facilities in Germany and every single one undergoes a mechanical and electrical function test there. It is this combination of technology and effective quality control that helps to safeguard Weishaupt's renowned reputation for quality.

A new burner is always an investment in the future. Costs always need to be well-balanced against use but, ultimately, long-term overall success depends on quality, technology, and safety. Deciding on a Weishaupt burner is always a safe investment in the future.



A hallmark of practical combustion technology

A safe investment in the future

Reliable and economical: The million-fold success of Weishaupt's compact burners is the result of an unrelenting orientation towards quality and customer satisfaction. The equipment has been continually developed and improved over decades.

The latest production methods and very stringent quality checks of all products ensure Weishaupt's reputation for quality. In choosing Weishaupt you are making a safe investment in the future.

Large capacity range

The large capacity range of 16.5 to 570 kW makes the burners suitable for a wide range of heat generators.

Digital combustion management for reliability and ease of use

Weishaupt is a pioneer in this field. Digital combustion management offers greater ease of use, simple servicing, even greater reliability in operation, and, last but not least, an extremely attractive price to capacity ratio. Furthermore, this intelligent technology enables the burner to be integrated with complex building management systems.

Electronic ignition

The ignition unit used on all Weishaupt W-series burners is very energy efficient and extremely reliable.

Flame monitoring

Flame monitoring systems are responsible for the high operational readiness and maximal safety of the burner.

Photo-resistors have been established across the Weishaupt WL burner range for many decades. They are designed for intermittent operation with the W-FM05 and W-FM10 combustion managers and respond to the light from the burner's flame. The self-checking W-FM25PO combustion manager enables burners to be used for continuous firing.

Burners with oil preheating

H-version oil burners are equipped with oil preheating. This allows optimal flame stability to be achieved, even at low burner ratings.

Weishaupt nozzle shutoff system

All WL5 burners with oil preheating are equipped with Weishaupt's nozzle shutoff system. This shuts off the oil completely whilst the nozzle assembly is brought up to temperature and prevents any drips after the burner has been switched off.

Sound-attenuated air inlet

The burners have a transverse fan with a sound-attenuated air inlet and, as a consequence, are particularly quiet in operation.

Electronically controlled air damper

The electronically controlled air damper fully closes at burner shutdown to hinder the cooling down of the combustion chamber.

Continuous firing, VSD, and O₂ trim

The various options available with the W-FM25 series of combustion managers used on WL30 and WL40 burners bring the latest technology to the compact burner segment. Innovative technology enables efficiency-optimising measures such as variable speed drive and O₂ trim to be produced more cost effectively.

With these technologies it is possible for investments in burners with staged load control to be quickly amortised. The W-FM25PO for continuous firing is well-suited to industrial applications. Its safety features allows burners to fire for more than 24 hours without a shutdown.

Service case

The Weishaupt service case for burner sizes up to WL20 facilitates the sensible storage of spare parts and optimal service readiness. All the parts needed for repairs and service work are clearly arranged in this handy and robust plastic case.

Diagnosis via laptop

A laptop computer can be connected to the combustion manager, offering easy combustion optimisation and fault analysis. A package of interrogation software and connection cables is available for this.

Outstanding service

Weishaupt has an extensive worldwide sales and service network. Customer service is available around the clock. Weishaupt's optimal in-house training ensures service technicians are of the highest calibre.

Trustworthy technology

Compact construction

Remove the burner's cover and you are immediately struck by how clearly its components are arranged, and how the electrical connections are obvious and non-interchangeable. The equipment makes a very good impression, just as Weishaupt always does.

Whichever model, each WL burner's compact construction means it can be easily installed by one person, reducing installation costs to a minimum.

Weishaupt nozzle shutoff system

All Low-NO_x burners are equipped with Weishaupt's nozzle shutoff system. This ensures a tight oil shutoff at the nozzle assembly, preventing any drips after the burner has been switched off.

Low-NO_x version

There are Low-NO_x versions available for all WL burner sizes. A specially designed mixing head generates an intensive internal flue gas recirculation that results in exemplary emission levels.

Sound-attenuated air inlet

The burners have a transverse fan with a sound-attenuated air inlet and, as a consequence, are particularly quiet in operation.

Servicing position

A special bracket allows the burner to be put into a servicing position, providing easy access to the burner and its mixing assembly.

Common platform

The common platform principle used with W-series burners greatly simplifies the provision and storage of spare parts.

Diagnosis via laptop

A laptop computer can be connected to the combustion manager, offering easy combustion optimisation and fault analysis. A package comprising interrogation software and connection cables is available for this.

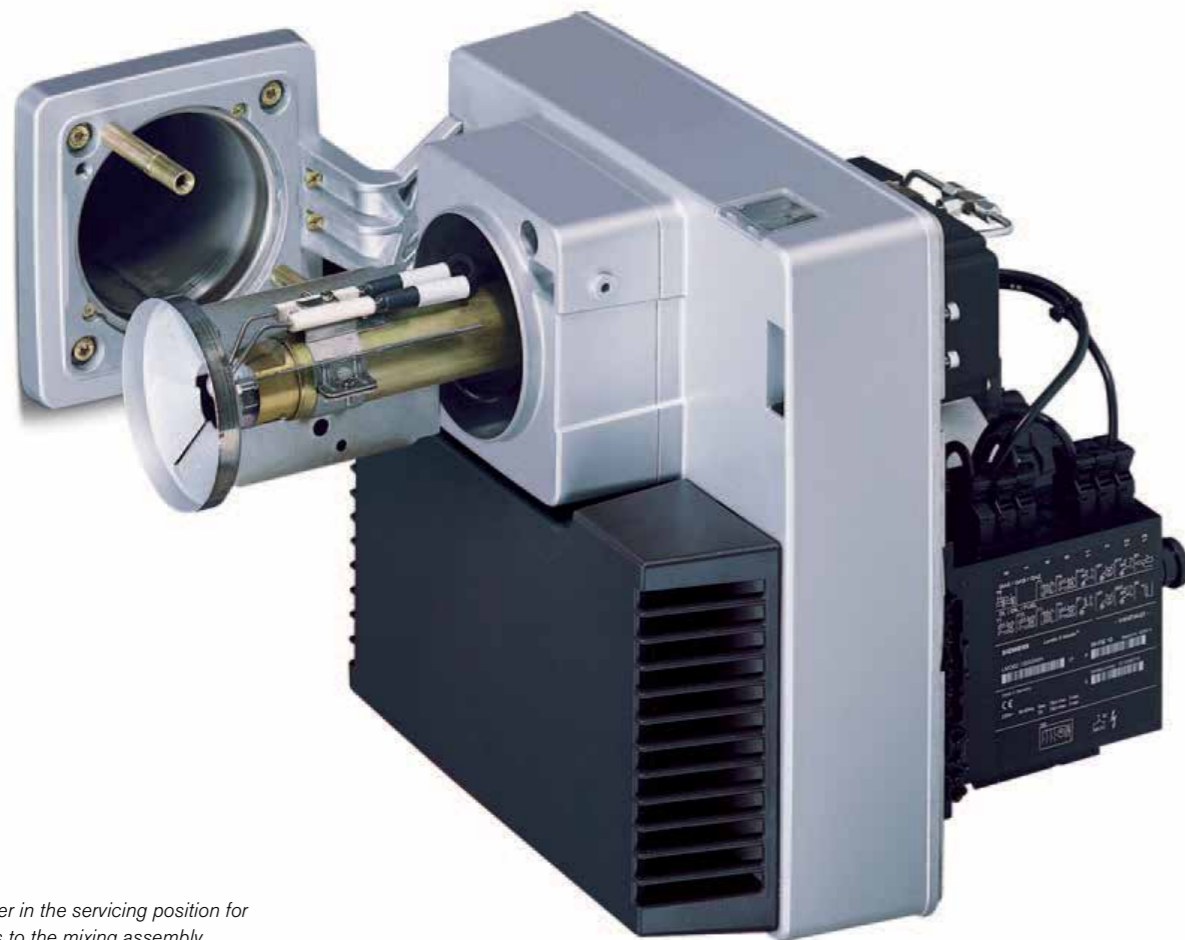

WL20 burner in the servicing position for easy access to the mixing assembly

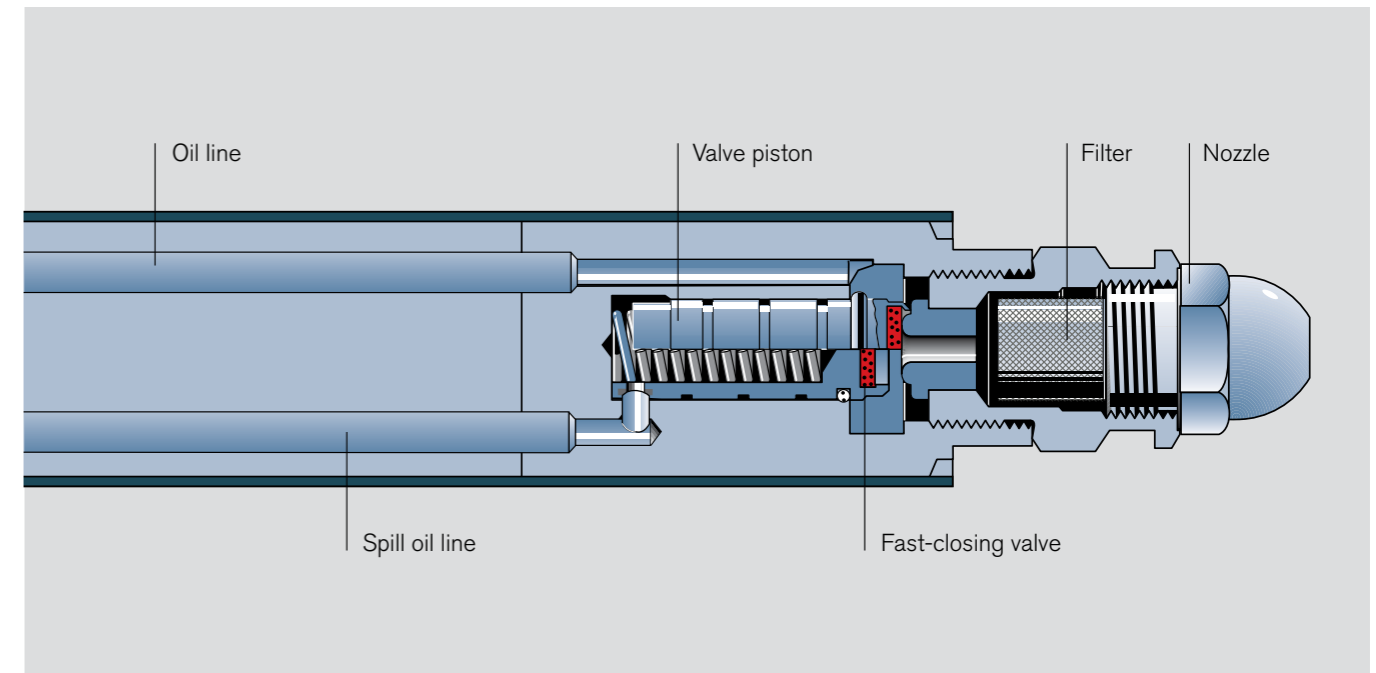

Weishaupt nozzle shutoff system

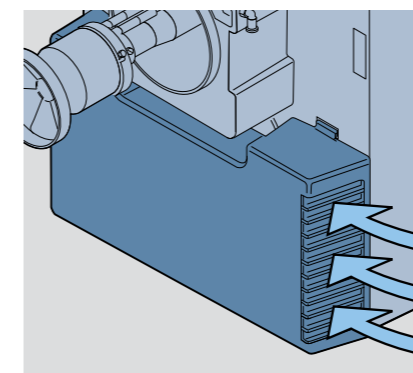

Sound-absorbing air inlet housing

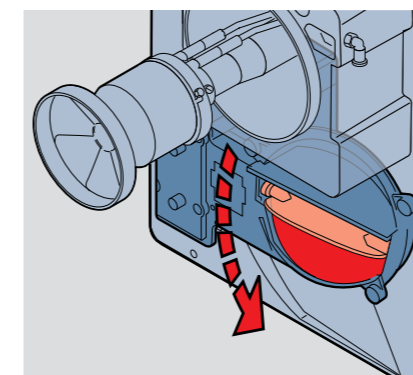

Electronically controlled air damper

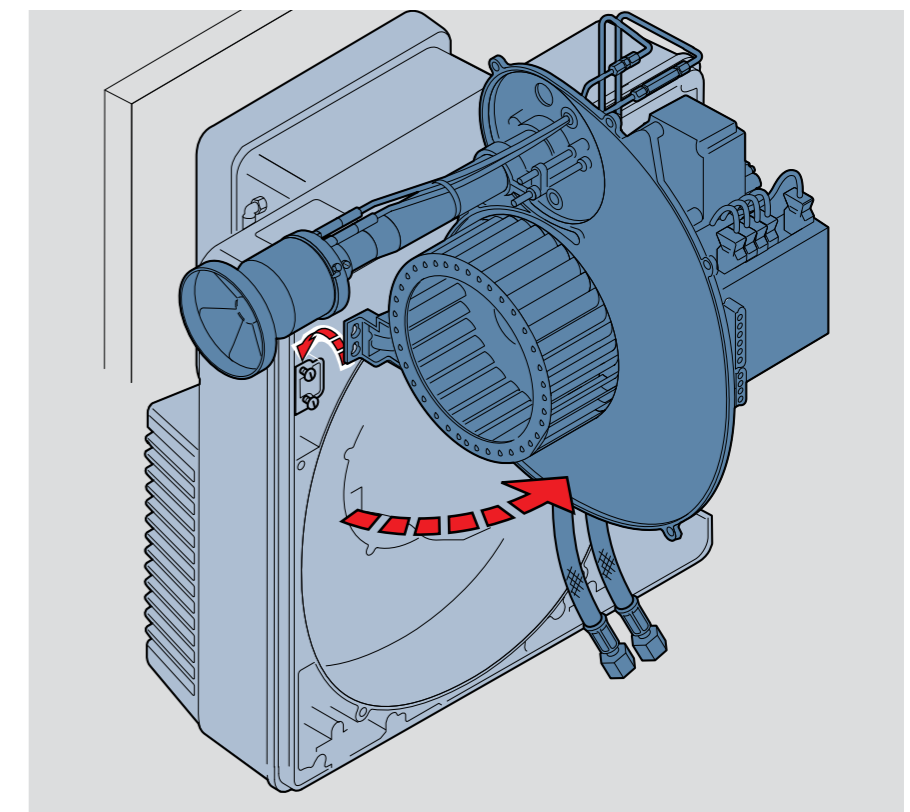

Housing with components in the servicing position: easy access to the fan wheel

Digital combustion management: reliable and easy to use

All of Weishaupt's W-series burners are fitted as standard with a digital combustion manager. The unit's microprocessors control and monitor all burner functions. As a result, Weishaupt burners are easy to use, precise, and reliable.

The digital combustion manager also offers the possibility of communicating with other systems via an integrated bus connection. This allows a technician to monitor the operation of the burner and remotely diagnose any errors.

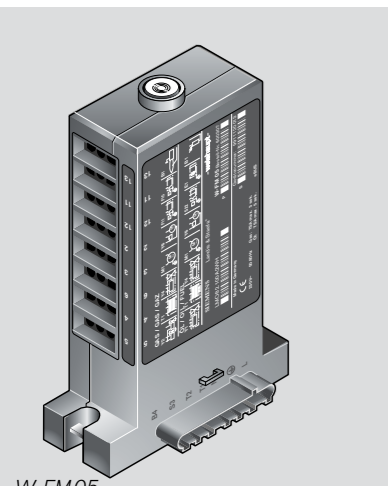

W-FM05

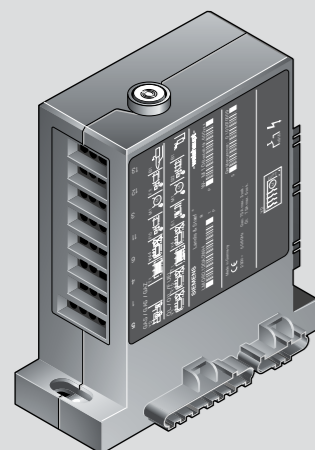

W-FM10

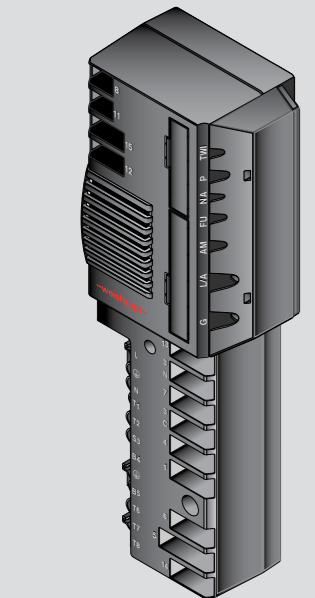

W-FM25

Combustion manager	W-FM 05	W-FM 10	W-FM 25
Fuels			
Gaseous	●	●	●
Liquid (distillate)	●	●	●
Gaseous / liquid (distillate)	-	-	●
Features			
Combustion manager for intermittent firing	●	●	●
Combustion manager for continuous firing > 24 h	-	-	○ ¹⁾
Integrated gas valve proving	-	●	●
Maximum number of actuators	1	1	2
Actuators with stepping motor	-	-	2
Maximum number of compound settings	-	-	2
Flame monitoring	lon	lon	lon
Fuel metering via input pulse	-	-	●
Service software	ACS 401	ACS 401	Vision Box
Efficiency optimisation			
Variable speed drive	-	-	○
O ₂ trim	-	-	○ ²⁾
Control			
Stage switching inputs (thermostat / pressure control)	●	●	●
Three-term switching input	-	-	●
0 / 4-20 mA or 0 / 2-10 V analogue input / output	-	-	○ ²⁾
Bus systems			
eBus	●	●	-
Modbus-RTU	-	-	○ ³⁾
Profibus	-	-	○ ³⁾
Controls positioning			
Burner-mounted combustion manager	●	●	●
Removable control unit	-	-	10 m
Electrical supply			
120 V, 50 Hz / 60 Hz	●	●	●
230 V, 50 Hz / 60 Hz	●	●	●
Approvals			
Europe	CE	(230 V / 50 Hz)	●
Australia	AGA	(240 V / 50 Hz)	●
USA / Canada	CSA	(120 V / 60 Hz)	●

● Standard ○ Optional ¹⁾ PO version ²⁾ PO O₂ version
³⁾ With EM3/3 expansion module ⁴⁾ With EM3/2 expansion module

WL30-40 with VSD and /or O₂ trim

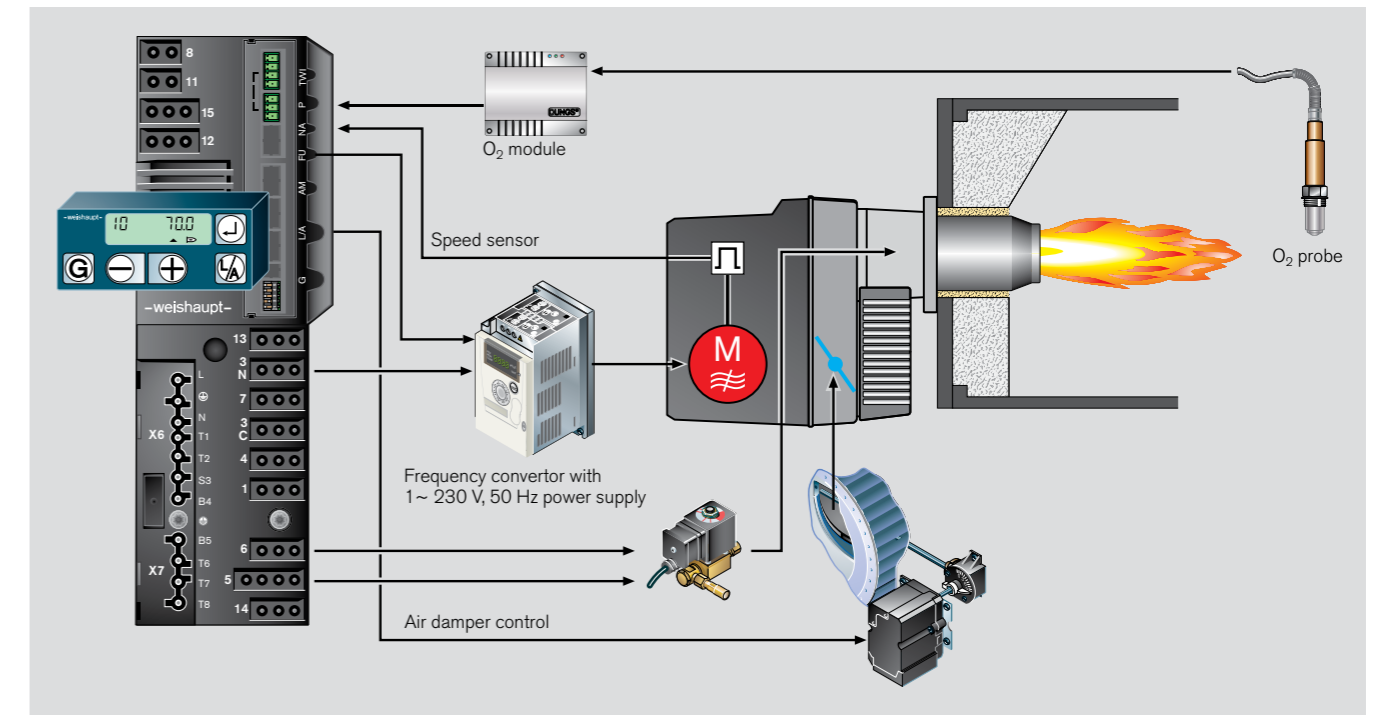

Conceptual drawing of WL30/40 with VSD and O₂ trim

The key points:

- The utilisation of identical units for gas and oil-fired burners helps simplify commissioning and reduces the number of spares required.
- Non-interchangeable plugs ensure the correct electrical connection of all components
- Electrical remote reset is possible
- Flame monitoring via photoresistor
- Safety is ensured by the reciprocal monitoring of two microprocessors
- Vari-coloured LED lamp to indicate burner operational stage and any fault conditions (WL5-20)
- LCD screen with interrogation, service, and parameterisation functions. The burner can be set directly via the operating keys (WL30-40)
- W-FM25 for continuous firing, VSD, and O₂ trim
- Air damper and frequency converter in electronic compound
- Adjustment of the O₂ setpoint curve and the minimum and maximum O₂ monitoring threshold
- Air volume can be adjusted via diffuser position, air damper position, and fan speed
- Separate ignition load setting
- High-precision, digital control
- Optional expansion modules with either a Modbus interface or analogue and digital inputs and outputs
- The separate PC connection offers, through the use of the Vision Box software, additional options such as:
 - Setting of the pre-purge time
 - Display of the operational sequence and the adjustment of functional parameters

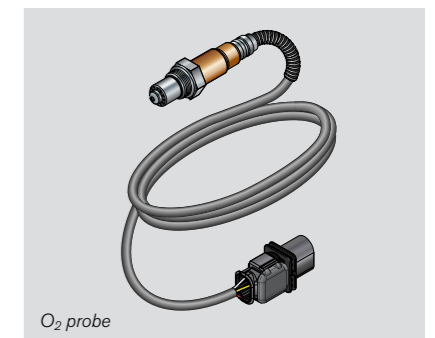

O₂ probe



O₂ module

Optional W-FM 25 expansion modules

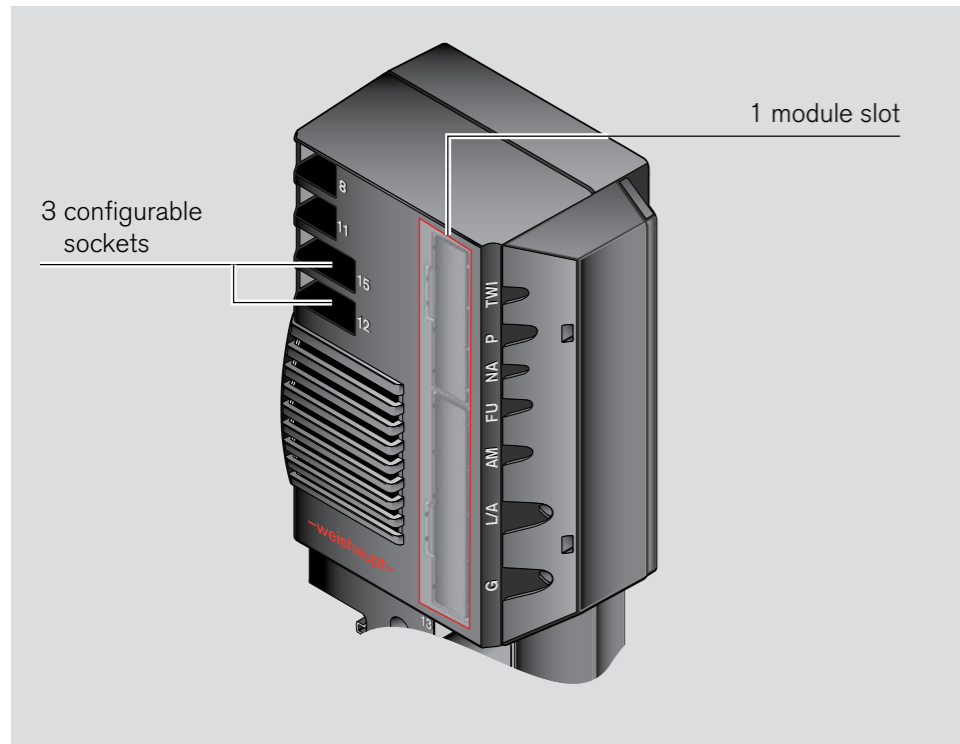

W-FM 25 combustion manager

- Configurable inputs (summary)
 - Socket 12
 - VPS valve proving
 - Proof of valve closure (POC)
 - Socket 14
 - Remote reset
 - Start release
 - Contact-dependent post-purge
 - Socket 15
 - High gas pressure switch
 - Extraneous air pressure switch

Use

Fuels

- Class D gas oil per BS 2869 / IS 251
- Class A2 gas oil per BS 2869 / IS 251
- 10 % biodiesel blends (B10)

The suitability of fuels of differing quality must be confirmed in advance with Weishaupt.

Applications

W-FM05 combustion manager for single-stage control

- Suitable for intermittent firing on:
- EN 303-compliant heat generators
 - LTHW boilers
 - Air heaters
 - Group II and III steam boilers

W-FM10 combustion manager for two-stage control

- Suitable for intermittent firing on:
- EN 303-compliant heat generators
 - LTHW boilers
 - Air heaters
 - Group II and III steam boilers

W-FM25 combustion manager for two-stage control

- Suitable for intermittent firing on:
- EN 303-compliant heat generators
 - LTHW boilers
 - Air heaters
 - Group II and III steam boilers

W-FM25PO combustion manager for two-stage control

- Suitable for intermittent firing on:
- EN 303-compliant heat generators
 - LTHW boilers
 - Air heaters
 - HTHW boilers
 - Group II, III, and IV steam boilers
 - Certain process applications

Protection Class

IP 40

Permissible ambient conditions

- Ambient temperature
 - 10 to + 40 °C for gas firing
- Maximum 80 % relative humidity, no condensation
- The combustion air must be free of aggressive substances (halogens, chlorides, fluorides etc.) and impurities (dust, debris, vapours, etc.)
- Adequate ventilation is required for operation in enclosed spaces
- For plant in unheated areas, certain further measures may be required

Use of the burner for other applications or in ambient conditions not detailed above is not permitted without the prior written agreement of Max Weishaupt GmbH. Burner service intervals will be reduced to accord with the more extreme operational conditions.

Capacity graphs per EN 267

The stated ratings are based on an air temperature of 20 °C and an installation altitude of 500 m above sea level.

Stated oil throughputs are for gas oil with a LHV of 11.9 kWh/kg.

Standards compliance

The burners are tested by an independent body and fulfil the applicable requirements of the following European Union directives and applied standards:

- EMC** EMC Directive 2014/30/EU
Applied standards
 - EN 61000-6-1 : 2007
 - EN 61000-6-3 : 2007
- LVD** Low-Voltage Directive 2014/35/EU
Applied standards
 - EN 60335-1 : 2010
 - EN 60335-2-102 : 2010
- MD** Machinery Directive 2006/42/EC
Applied standards
 - EN 676 Annex J

The burners are labelled with

- CE Mark
- DIN CERTCO

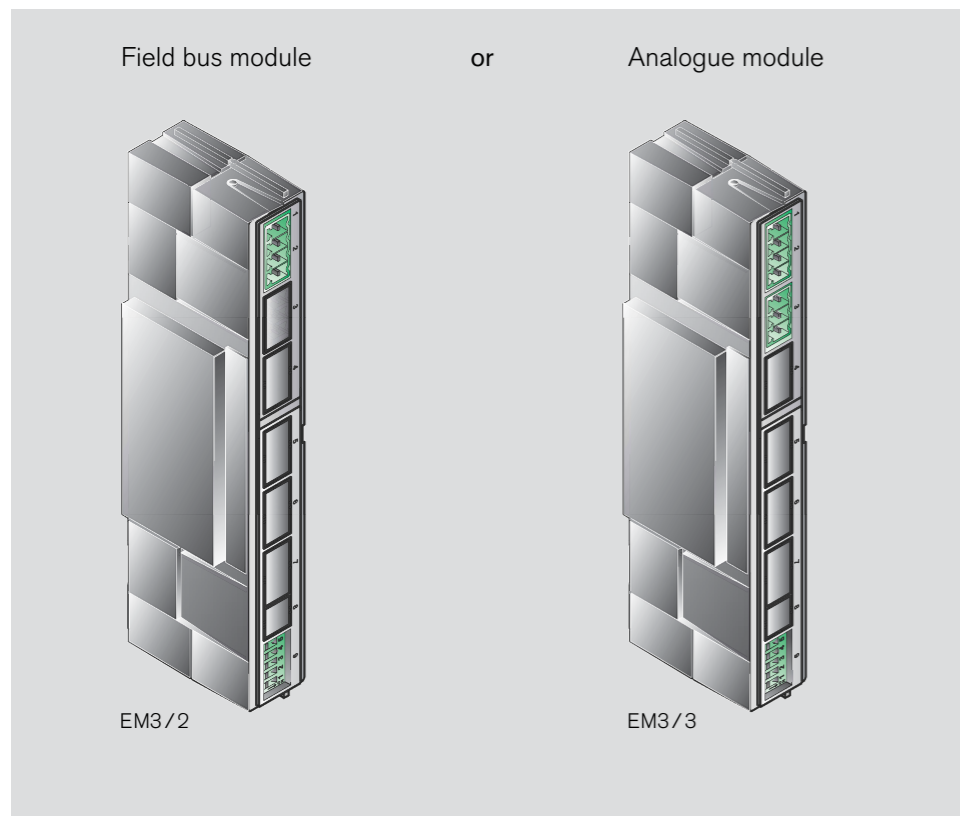

Field bus module – Modbus/Profibus

By way of example, the following data can be read or changed:

- Burner ON/OFF
- Fuel changeover
- Current degree of modulation
- Required degree of modulation
- Heat demand present
- Flame signal
- Hardware inputs and outputs
- Operating phase
- Hours run
- Fan speed with VSD
- Actuator positions
- Fuel throughputs
- Etc.

Analogue module – input/output

Input: Required burner load
0–20 mA / 4–20 mA
0–10 V / 2–10 V

Output: Current burner load
0–20 mA / 4–20 mA
0–10 V / 2–10 V

Model designation

Model	Version
WL5/1-B-H 2LN	
WL	Mixing assembly
5	Suffix
/1	Mark
B	Capacity
-	Size
H	Fuel, oil
2LN	Burner series

Details	Code	Meaning
Series	W	Compact burner
Fuel	L	Oil
Load control	-	Single-stage
	Z	Two-stage
Mixing assembly	-	Standard
	2LN	Low-NO _x
Suffix	H	Oil preheating

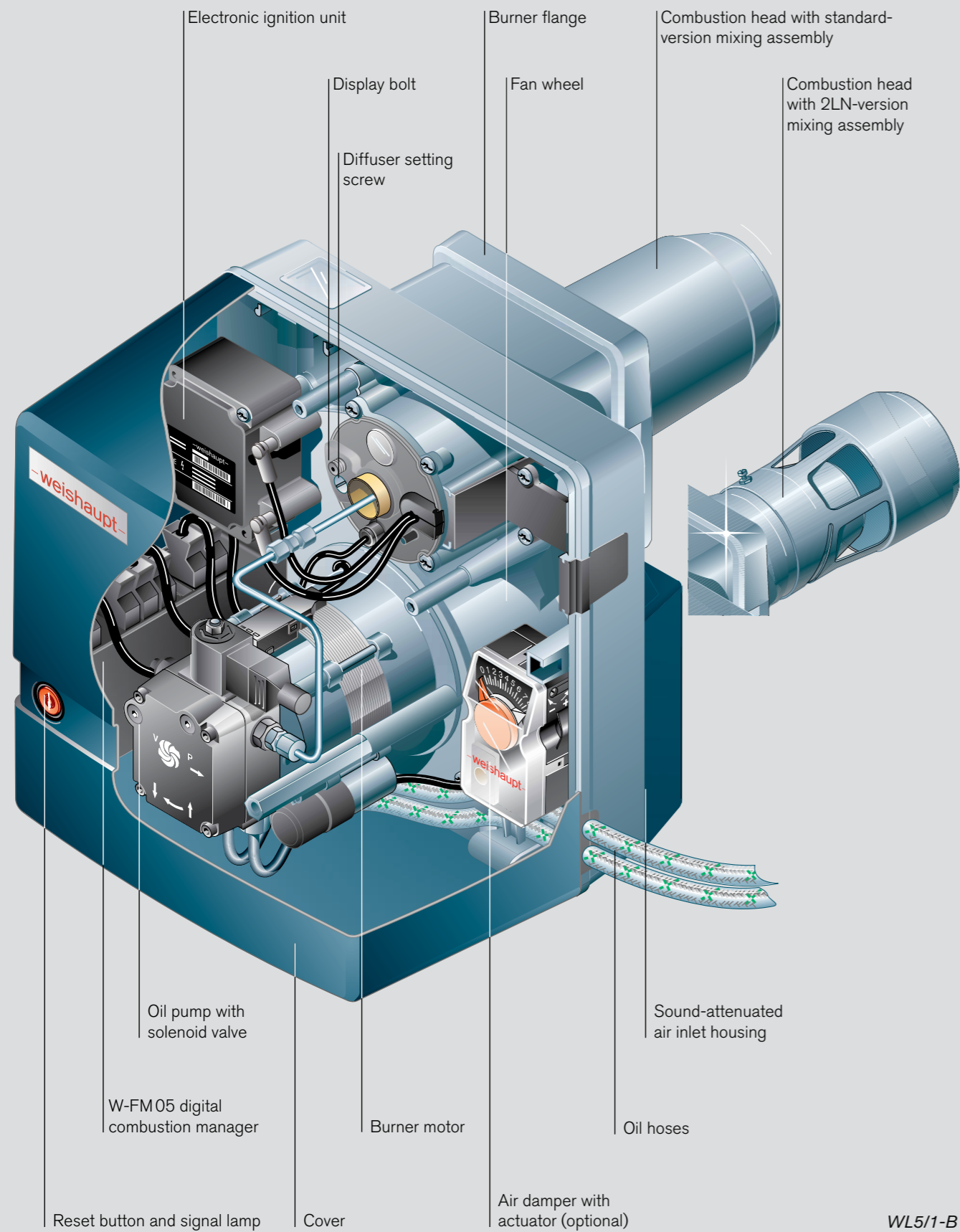

Burner selection WL5

WL5 capacity graph

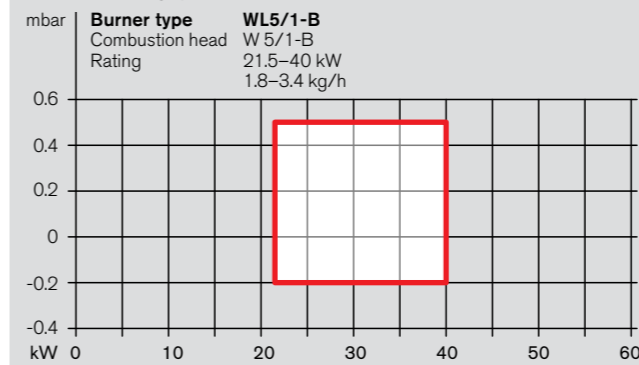

WL5 capacity graph

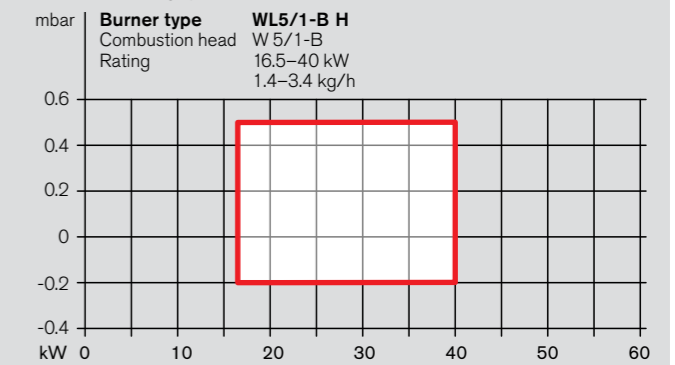

WL5 capacity graph

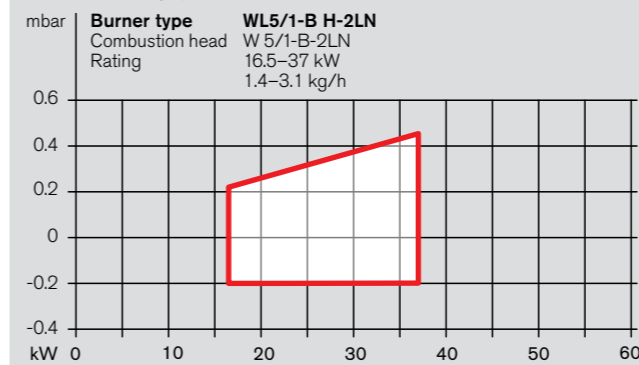

WL5 capacity graph

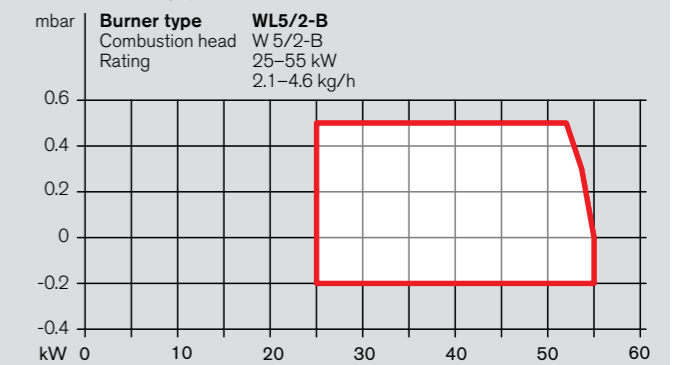

Burner type	Version	Operation	Burner rating	Oil throughput	Power consumption	Order No.
WL5/1-B	Standard	Single-stage	21.5–40 kW	1.8–3.4 kg/h	0.14 kW	241 051 21
WL5/1-B	Standard	Single-stage with actuator	21.5–40 kW	1.8–3.4 kg/h	0.14 kW	241 051 20
WL5/1-B	H	Single-stage with preheating	16.5–40 kW	1.4–3.4 kg/h	0.14 kW	242 051 21
WL5/1-B	H	Single-stage with preheating and actuator	16.5–40 kW	1.4–3.4 kg/h	0.14 kW	242 051 20
WL5/1-B	H-2LN	Single-stage	16.5–37 kW	1.4–3.1 kg/h	0.14 kW	242 051 25
WL5/2-B	Standard	Single-stage with actuator	25.0–55 kW	2.1–4.6 kg/h	0.14 kW	241 051 31
WL5/2-B	Standard	Single-stage with preheating and actuator	25.0–55 kW	2.1–4.6 kg/h	0.14 kW	241 051 30

Extra equipment WL5

Extra equipment	WL5 ...-B	1-B H	1-B H-2LN	Order No.
Integral hours-run counter	●	●	●	240 003 20
Integral oil meter	●	●	●	240 003 45
Solenoid valve and adaptor plug for continuous-run fan or post-purge	●	●	●	240 003 48
Air inlet flange for duct connection, with air pressure switch	●	●	●	240 004 11
Remote reset	●	●	●	240 003 55
Plugged cable for connection of an external solenoid valve	●	●	●	240 003 49
ST18/7 plug connection	●	●	●	240 003 24
30 mm spacer flange	●	●	●	240 003 22
Burner rotated through 180°	●	●	●	240 003 44

Dimensions

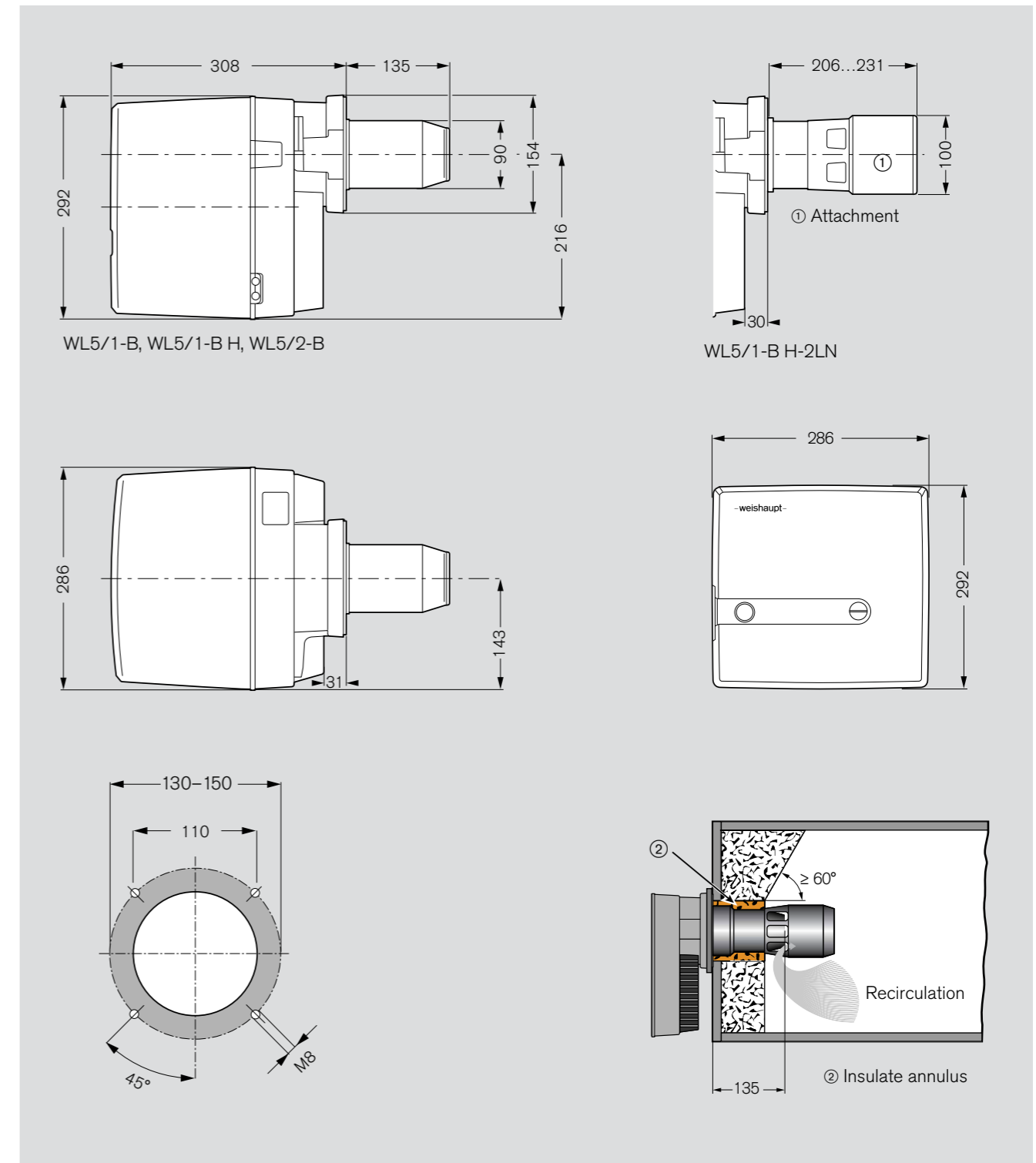

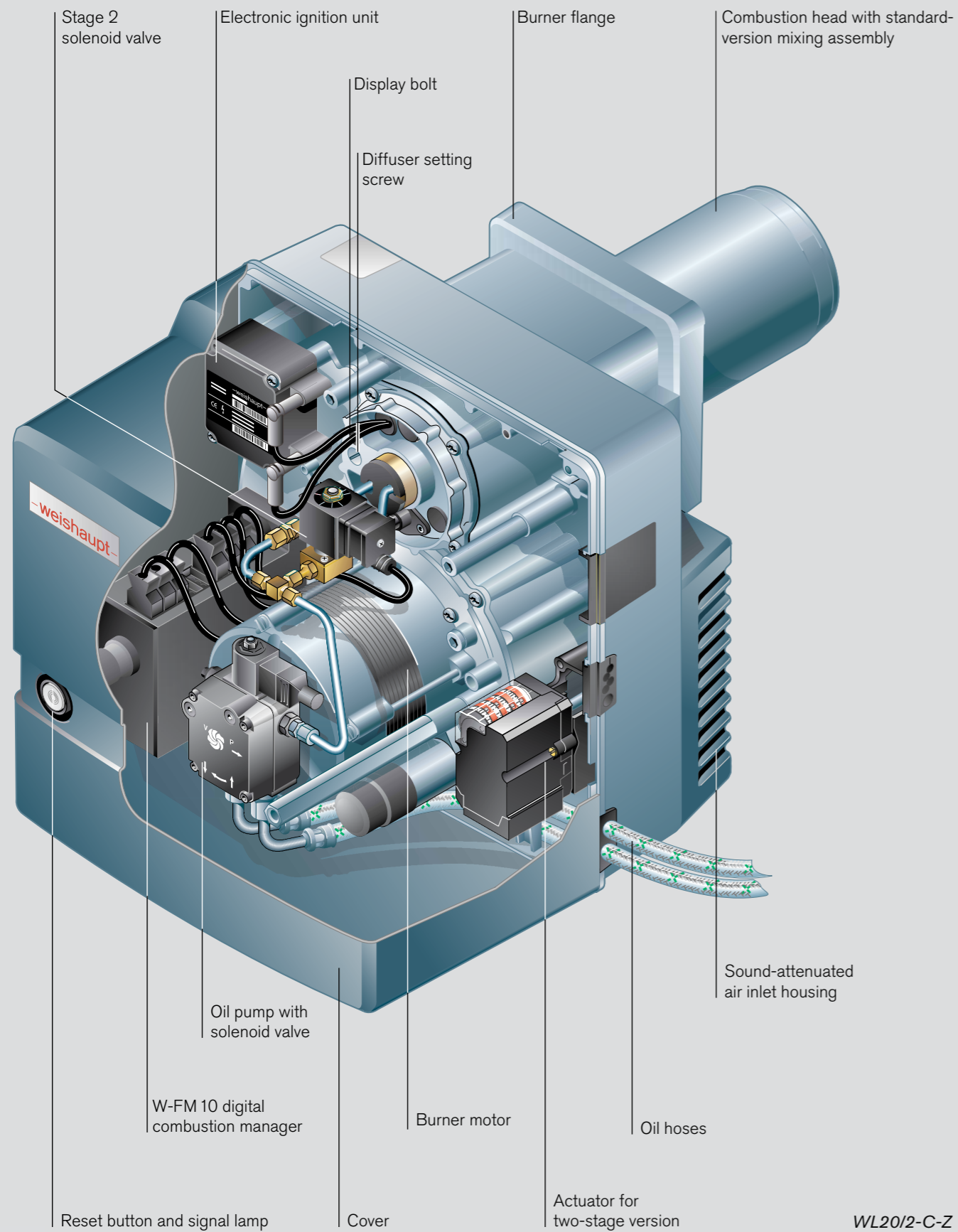

Burner selection WL10 to WL40

WL10/2 capacity graph

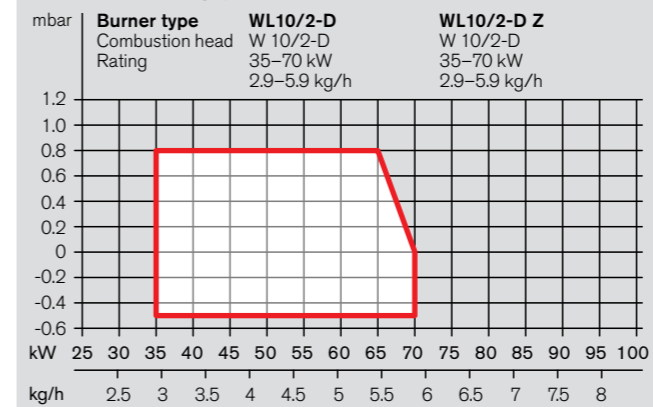

WL10/3 capacity graph

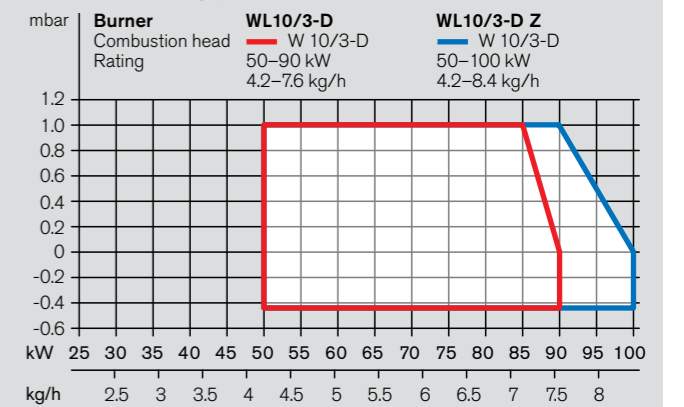

WL20/1 capacity graph

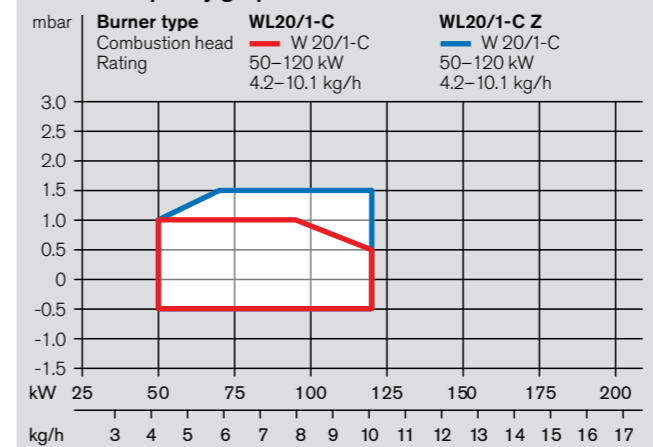

WL20/2 capacity graph

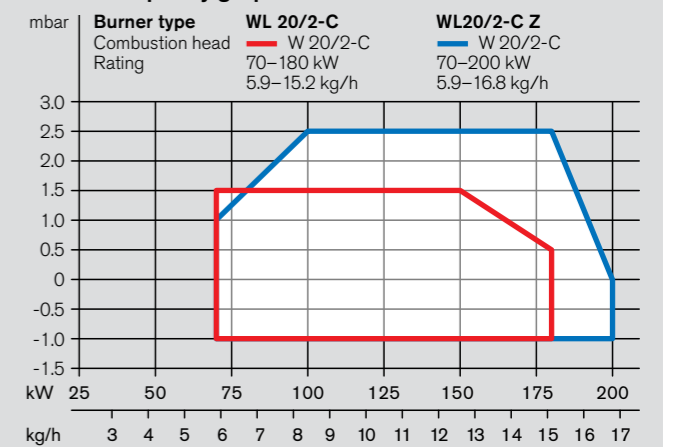

WL30 capacity graph

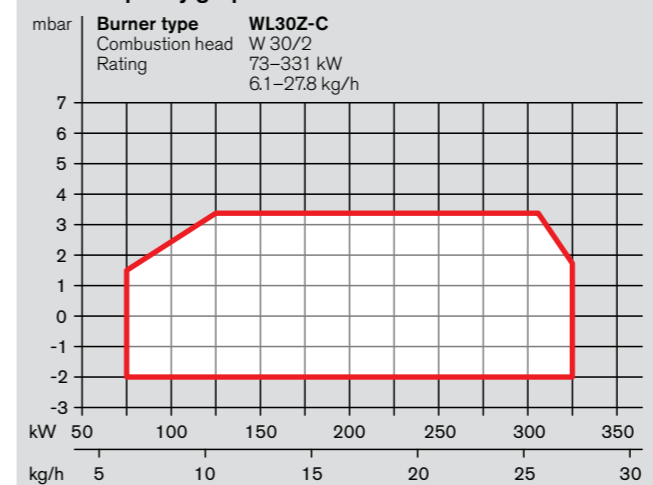

WL40 capacity graph

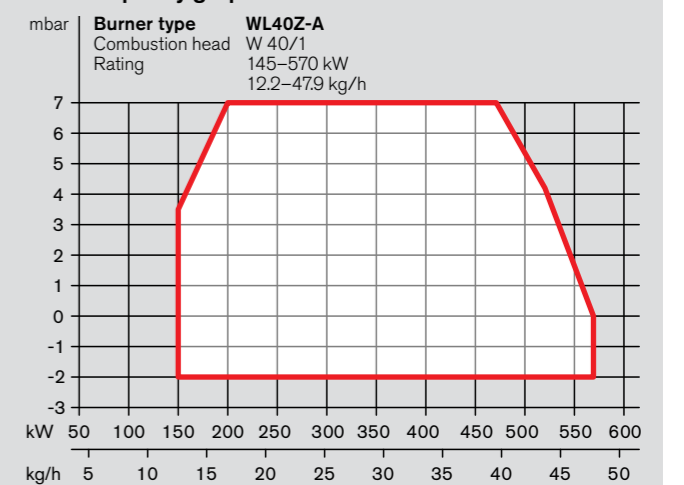

Low-NO_x burner selection WL10 to WL40

WL10 capacity graph

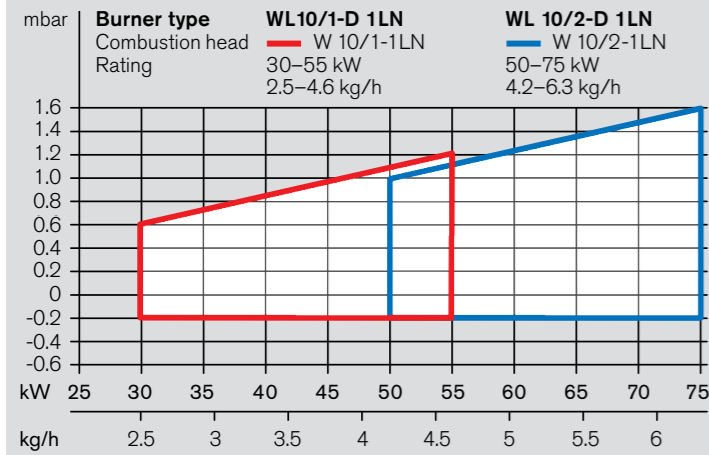

WL20 capacity graph

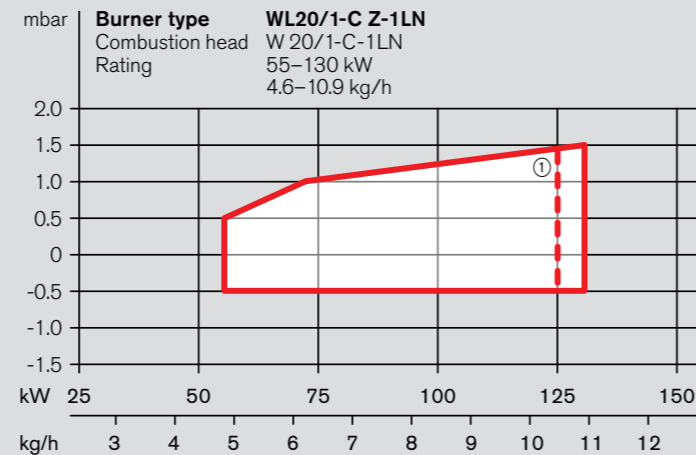

WL30 capacity graph

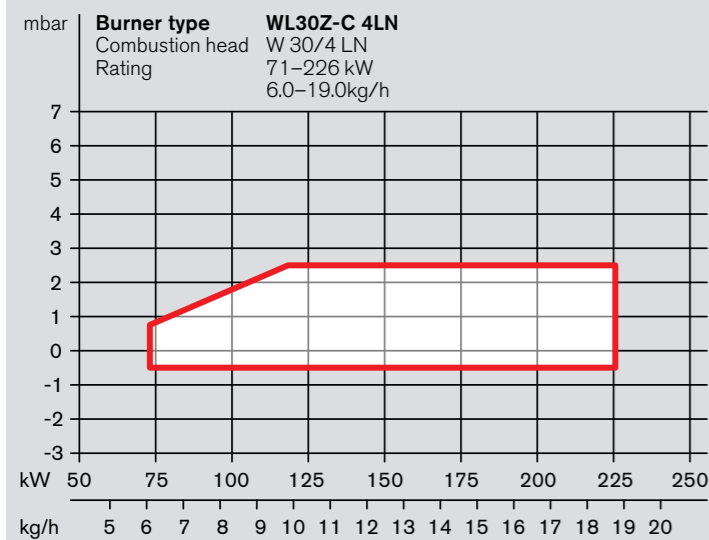

WL40 capacity graph

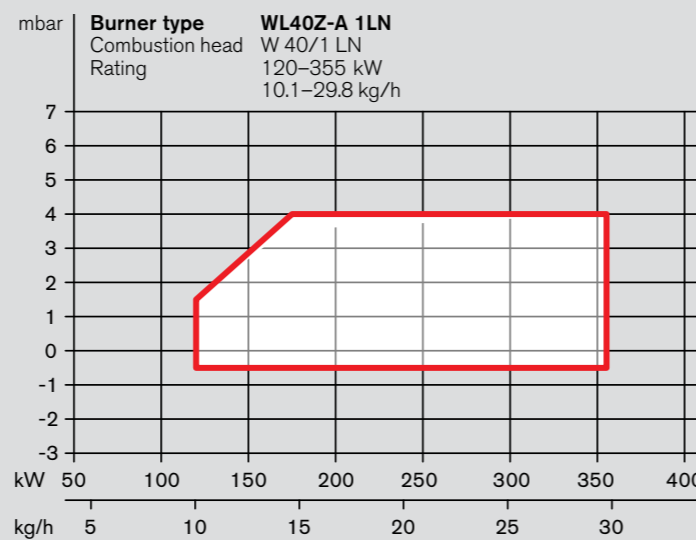

① Limitation for Switzerland:
For use on three-pass heat generators only

Model overview

Burner type	Version	Operation	Burner rating	Oil throughput	Power consumption	Order No.
Standard						
WL10/2-D	Standard	Single-stage	35–70 kW	2.9–5.9 kg/h	0.13 kW	241 111 22
WL10/2-D	Standard	Single-stage with actuator	35–70 kW	2.9–5.9 kg/h	0.13 kW	241 111 20
WL10/2-D	Z	Two-stage with actuator	35–70 kW	2.9–5.9 kg/h	0.13 kW	241 111 23
WL10/3-D	Standard	Single-stage	50–90 kW	4.2–7.6 kg/h	0.13 kW	241 110 31
WL10/3-D	Standard	Single-stage with actuator	50–90 kW	4.2–7.6 kg/h	0.13 kW	241 110 30
WL10/3-D	Z	Two-stage with actuator	50–100 kW	4.2–8.4 kg/h	0.13 kW	241 110 32
WL20/1-C	Standard	Single-stage	50–120 kW	4.2–10.1 kg/h	0.25 kW	241 210 21
WL20/1-C	Standard	Single-stage with actuator	50–120 kW	4.2–10.1 kg/h	0.25 kW	241 210 11
WL20/1-C	Z	Two-stage with actuator	50–120 kW	4.2–10.1 kg/h	0.25 kW	241 213 21
WL20/2-C	Standard	Single-stage	70–180 kW	5.9–15.2 kg/h	0.25 kW	241 210 22
WL20/2-C	Standard	Single-stage with actuator	70–180 kW	5.9–15.2 kg/h	0.25 kW	241 210 12
WL20/2-C	Z	Two-stage with actuator	70–200 kW	5.9–16.8 kg/h	0.25 kW	241 213 22
WL30-C	Z	Two-stage	73–331 kW	6.1–27.8 kg/h	0.42 kW	241 313 21
WL40-A	Z	Two-stage	145–570 kW	12.2–47.9 kg/h	0.62 kW	241 403 21
Low-NO_x						
WL10/1-D	1LN	Single-stage	30–55 kW	2.5–4.6 kg/h	0.13 kW	241 110 15
WL10/2-D	1LN	Single-stage	50–75 kW	4.2–6.3 kg/h	0.13 kW	241 110 25
WL20/1-C	Z-1LN	Two-stage	55–130 kW	4.6–10.9 kg/h	0.25 kW	241 213 25
WL30-Z-C	4LN	Two-stage	71–226 kW	6.0–19.0 kg/h	0.42 kW	241 313 26
WL40-Z-A	1LN	Two-stage	120–355 kW	10.1–29.8 kg/h	0.62 kW	241 403 25

Extra equipment WL10

Extra equipment	WL10/2		WL10/3		WL10		Order No.
	D	D-Z	D	D-Z	1-D 1LN	2-D 1LN	
Combustion head extension	by 100 mm	●	●	●	●	●	240 003 93 240 004 04 240 004 37 240 004 38
		●	●	●	●		240 003 94 240 004 05
		●	●	●	●		240 003 95 240 004 06
Integral hours-run counter	●	●	●	●	●	●	240 003 89 240 003 90
Integral oil meter with additional solenoid valve	●	●	●	●	●	●	240 004 18
Solenoid valve and adaptor plug for continuous-run fan or post-purge	●	●	●	●	●	●	240 003 87
Air inlet flange for duct connection, with air pressure switch	●	●	●	●	●	●	240 004 69
Remote reset	●	●	●	●	●	●	240 003 55
Plugged cable for connection of an external solenoid valve	●	●	●	●	●	●	240 003 49
ST18/7 plug connection	●	●	●	●	●	●	240 003 24
30 mm spacer flange	●	●	●	●	●	●	240 003 75
Burner rotated through 180°		●	●	●	●	●	240 004 34 240 004 35
			●		●		

Extra equipment WL20

Extra equipment	WL20/1		WL20/2		WL20/1 CZ-1LN	Order No.
	C	C-Z	C	C-Z		
Combustion head extension	by 100 mm	●	●	●	●	240 003 81 240 003 84 240 002 83
		●	●	●	●	240 003 82 240 003 85
		●	●	●	●	240 003 83 240 003 86
Integral hours-run counter	●	●	●	●	●	240 003 89 240 003 90
Integral oil meter with additional solenoid valve	●	●	●	●	●	240 003 34
Solenoid valve and adaptor plug for continuous-run fan or post-purge	●	●	●	●	●	240 003 87
Air inlet flange for duct connection, with air pressure switch	●	●	●	●	●	240 004 69
Remote reset	●	●	●	●	●	240 003 55
Plugged cable for connection of an external solenoid valve	●	●	●	●	●	240 003 49
ST18/7 plug connection	●	●	●	●		240 002 15
Slotted 18 mm spacer ring for 150–170 mm PCD (required for boiler ratings < 70 kW)	●	●	●	●	●	240 002 81
30 mm spacer flange	●	●	●	●	●	240 003 75
Burner rotated through 180°		●	●	●	●	240 004 08 240 004 09 240 004 10
			●		●	●

Extra equipment WL30 and WL40

Extra equipment	WL30 Z-C	WL40 Z-A	WL30 Z-C 4LN	WL40 Z-A 1LN	Order No.
Combustion head extension	●	by 100 mm	●		240 002 85 240 002 63 240 002 95
		by 200 mm	●		240 003 43
		by 300 mm	●		240 003 73
Note: Burners with extended combustion heads cannot be hinged open!					
Integral oil meter	●	●	●	●	240 002 86 240 002 66 240 002 87 240 002 67
Oil hoses, 1500 mm in lieu of 1200 mm	●	●	●	●	240 002 76
Adaptor plug for continuous-run fan or post-purge		●		●	240 002 80
Solenoid valve and adaptor plug for continuous-run fan or post-purge	●		●		240 003 41
Air inlet flange for duct connection, with air pressure switch	●	●	●	●	240 004 99 240 005 00
Remote reset	●	●	●	●	240 005 02
Adaptor for connection of an external solenoid valve	●	●	●	●	240 005 03
LGW air pressure switch and DSF min. oil pressure switch for PED compliance	●	●	●	●	240 003 33
W-FM25 PO combustion manager for continuous burner firing > 24 h and/or O ₂ trim	●	●	●	●	240 005 19
EM 3/3 analogue expansion module	●	●	●	●	240 005 07
EM 3/2 field bus expansion module (Profibus/Modbus-RTU)	●	●	●	●	230 011 52
VSD with integral frequency convertor	●	●	●	●	240 005 14
		●	●	●	240 005 15
O ₂ trim set, comprising O ₂ module, O ₂ probe, probe flange, and connection cables with plugs	●	●	●	●	230 012 34

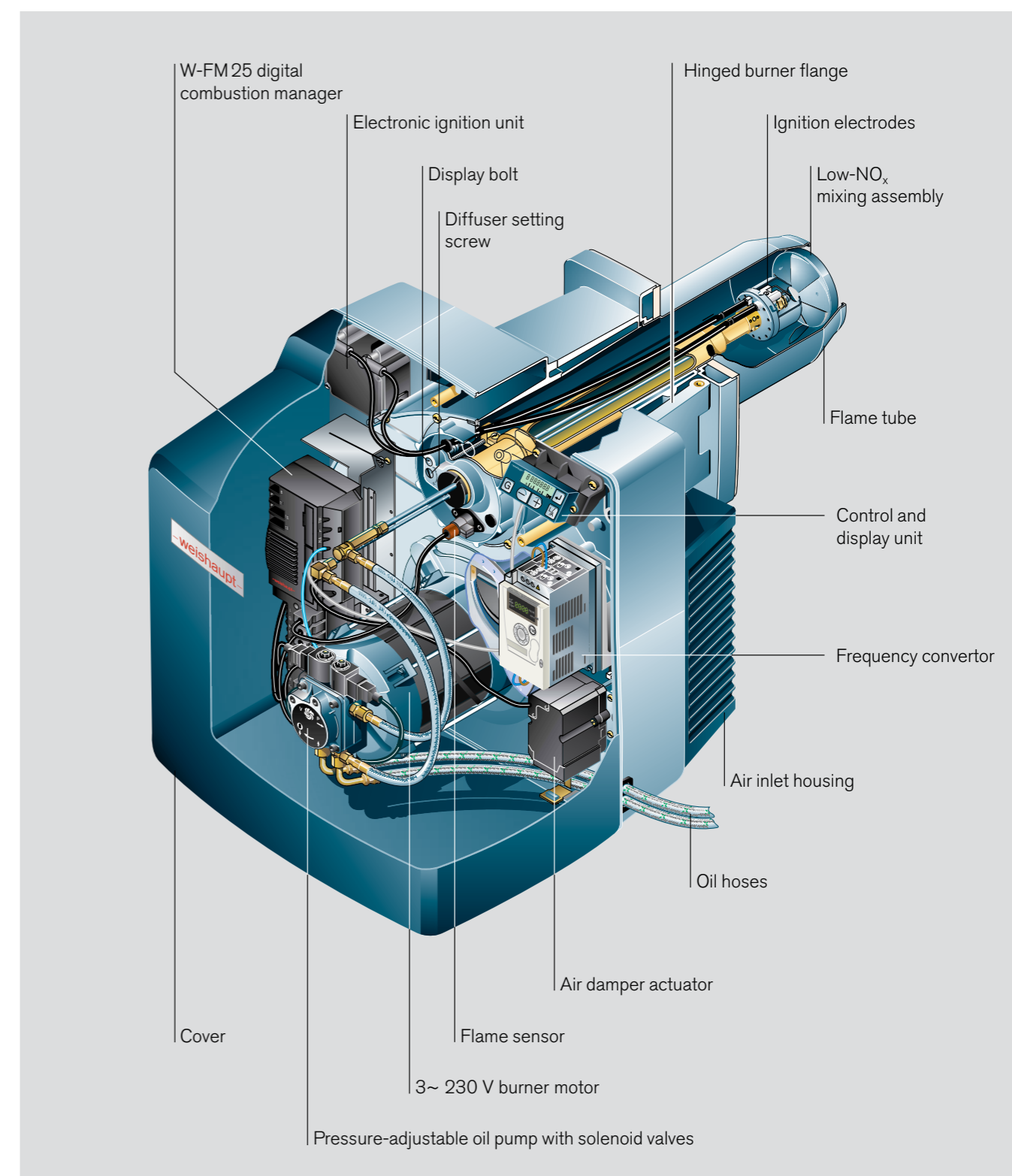

Dimensions

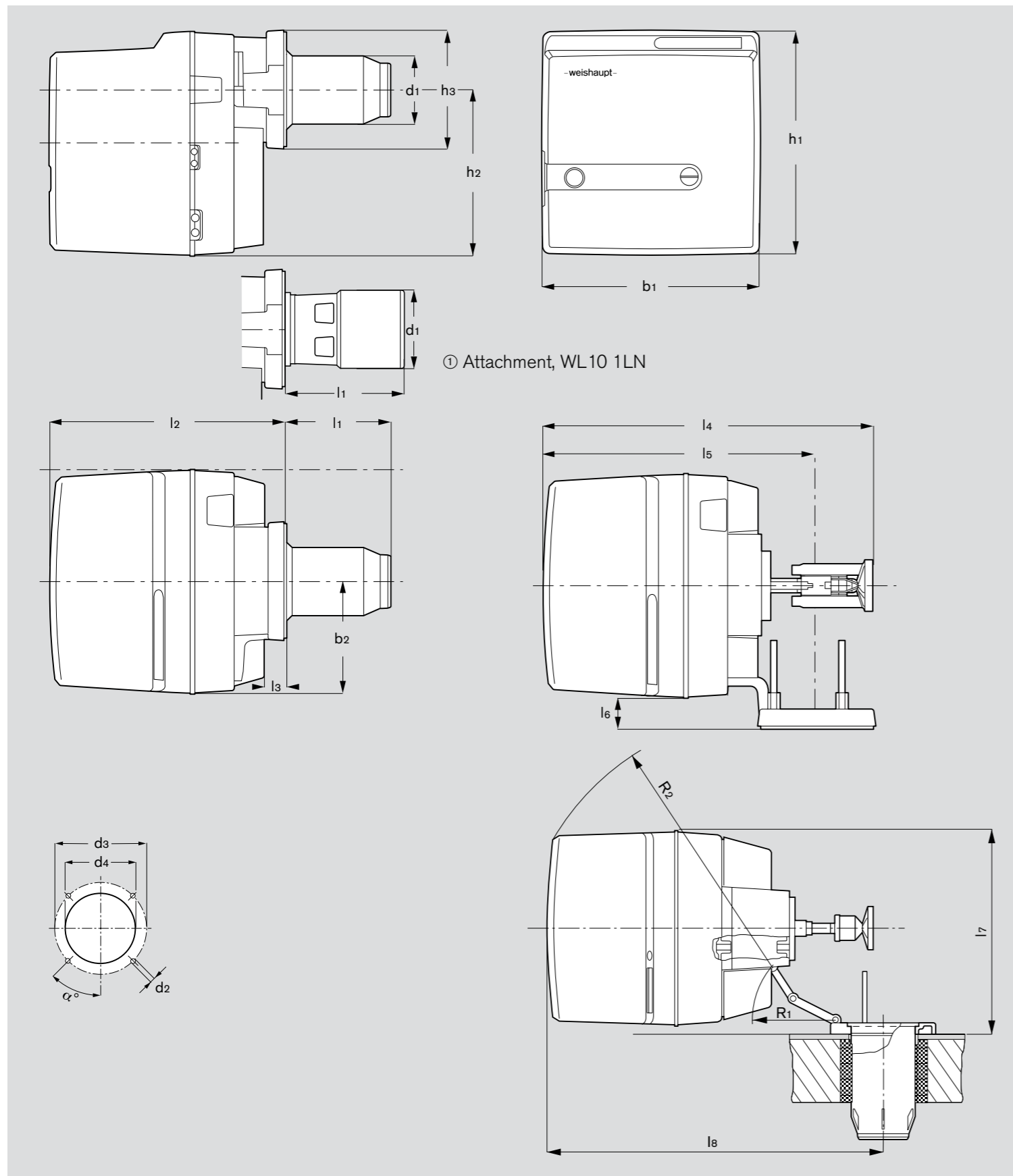

Burner type	Dimensions in mm														
	l ₁	l ₂	l ₃	l ₄	l ₅	l ₆	l ₇	l ₈	b ₁	b ₂	b ₃	h ₁	h ₂	h ₃	h ₄
Standard															
WL10/2-D	137	344	32	476	398	51	-	-	330	165	-	353	270	165	-
WL10/3-D	140	344	32	476	398	51	-	-	330	165	-	353	270	165	-
WL20/1-C	140	393	32	525	434	73	-	-	358	179	-	376	285	182	183
WL20/2-C	174	393	32	558	434	73	-	-	358	179	-	376	285	182	183
WL30Z-C	172	480	62	640	600	62	460	600	420	226	100	460	342	-	-
WL40Z-A	242	577	72	801.5	615	72	480	615	450	245	108	480	360	-	-
Low-NO_x															
WL10/1-D 1LN	232-252	344	31.5	476	398	51	-	-	330	165	-	353	270	165	-
WL10/2-D 1LN	232-257	344	31.5	476	398	51	-	-	330	165	-	353	270	165	-
WL20/1-C 1LN	141	393	32	532	434	73	-	-	358	179	-	376	285	182	183
WL30Z-C 4LN	170	480	62	639	600	62	460	600	420	226	100	460	342	-	-
WL40Z-A 1LN	238	577	72	795	615	72	480	615	450	245	108	480	360	-	-
Burner type	Dimensions in mm														
	d ₁	d ₂	d ₃	d ₄	d ₅	d ₆	R ₁	R ₂	α°						
Standard															
WL10/2-D	99	M8	150-170	110	-	-	-	-	-						
WL10/3-D	1108	M8	150-170	110	-	-	-	-	-						
WL20/1-C	108	M8	170	130	123	150	-	-	-						
WL20/2-C	120	M8	170	130	123	150	-	-	-						
WL30Z-C	127	M8	170-186	130	-	-	158	490	45						
WL40Z-A	151	M10	186-200	160	-	-	185	570	45						
Low-NO_x															
WL10/1-D 1LN	100	M8	150-170	110	-	-	-	-	-						
WL10/2-D 1LN	108	M8	150-170	110	-	-	-	-	-						
WL20/1-C 1LN	108	M8	170	130	123	150	-	-	-						
WL30Z-C 4LN	127	M8	170-186	130	-	-	158	490	45						
WL40Z-A 1LN	151	M10	186-200	160	-	-	185	570	45						

Technical data

Burner type	Combust. manager	Motor	Actuator	Frequency convertor	Flame monitoring	Oil pump	Ignition unit	Burner mass ^①	Noise emission ^②
WL5									
All versions	W-FM05	ECK 02/H-2 230 V, 50 Hz 0.075 kW Cap. 4 µF	None, or optional W-St 02/1	–	Photoresistor QRB4B	ALV 30C 55 l/h at 14 bar	W-ZG01V	11.0 kg	55 dB(A)
WL10									
Vers. 2-D Vers. 3-D Vers. 1-D 1LN Vers. 2-D 1LN Vers. 2-D Z Vers. 3-D Z	W-FM05 W-FM10	ECK 03/H-2 230 V, 50 Hz 0.13 kW Cap. 3 µF	None, or optional W-St 02/2 STD 4,5	–	Photoresistor QRB4B	ALV 30C 55 l/h AT2 V 45C 60 l/h	W-ZG01V	14.0 kg	62 dB(A)
WL20									
Vers. 1-C Vers. 2-C Vers. 2-C Z	W-FM05 W-FM10	ECK 04/A-2 230 V, 50 Hz 0.25 kW Cap. 4 µF	None, or opt. W-St 02/2 STD 4,5	–	Photoresistor QRB4A	ALV 30C 55 l/h AT2 V 45C 60 l/h	W-ZG01V	20.0 kg 20.5 kg	68 dB(A)
Vers. 1-C Z Vers. 1-C Z-1LN					QRB4B				
WL30									
Vers. Z-C Vers. Z-C 4LN	W-FM25	ECK 05/A-2 230V; 50Hz 0.38 kW Cap 12 µF	STE 4,5 BO.36/6-01L	–	Photoresistor QRB4A	ALV 65C 75 l/h AT2 V 45C 60 l/h	W-ZG01V	28.0 kg	72 dB(A)
With O ₂ trim With VSD	W-FM25PO W-FM25	DK05/A-2 3~230V; 50Hz 0.42 kW		ATV 12				29.0 kg	
WL40									
Vers. Z-A Vers. Z-A 1LN	W-FM25	ECK 06/A-2 230V; 50Hz 0.53 kW Cap. 16 µF	STE 4,5 * BO.36/6-01L	–	Photoresistor QRB4A	ALV 65C 75 l/h AT2 V 55C 75 l/h	W-ZG01V	37.0 kg	74 dB(A)
With O ₂ trim With VSD	W-FM25PO W-FM25	DK06/A-2 3~230V; 50Hz 0.62 kW		ATV 12				38.0 kg	

① All masses are approximate.

② Measured sound pressure level.

Values in the field are subject to variation according to the characteristics of the entire acoustic system.



Contact Us

Maximising Energy Efficiencies for a Sustainable Future

admin@egl.com.au

www.environmental.com.au

03 9541 8699

Office Locations



Melbourne

Tomlinson Energy Services
Suite 2.01 | Level 2
315 Ferntree Gully Road
Mount Waverley VIC 3149
P: 03 8560 0416
E: energyservice.melbourne@tomlinsonenergy.com.au

Sydney

Tomlinson Energy Services
A2, 26 Power Road
Seven Hills NSW 2417
P: 02 9681 4177
E: energyservice.sydney@tomlinsonenergy.com.au

Brisbane

Tomlinson Energy Services
1/48 Commerce Circuit
Yatala QLD 4207
P: 07 3462 0159
E: energyservice.brisbane@tomlinsonenergy.com.au

South Australia

Tomlinson Energy Services
26 Phillips Street
Thebarton SA 5031
P: 08 8297 9688
E: energyservice.adelaide@tomlinsonenergy.com.au

Western Australia

Tomlinson Energy Services
40 Sorbonne Crescent
Canning Vale WA 6155
P: 08 9455 5511
E: energyservice.perth@tomlinsonenergy.com.au

